

User Manual



VDTU2-B110

VDSL2 LAN Extender



CTC UNION TECHNOLOGIES CO., LTD.

Copyright by CTC UNION Communications Inc., all right reserved

The information in this document has been checked carefully and is believed to be correct as of the date of publication. CTC UNION Communications Inc. reserves the right to make changes in the product of specification, or both, presented in this publication at any time without notice. CTC UNION Communications assumes no responsibility or liability arising from the specification listed herein. CTC UNION Communications make no representations that the use of its products in the manner described in this publication will not infringe on existing or future patents, trademark, copyright, or rights of third parties. Implication or other under any patent or patent rights of CTC UNION Communications Ins. grants no license. All other trademarks and registered trademarks are the property of their respective holders.

CTC Union Technologies Co., Ltd.

Far Eastern Vienna Technology Center (Neihu Technology Park)
8F, No. 60, Zhouzi St.
Neihu, Taipei, 114
Taiwan
Phone: +886-2-2659-1021
FAX: +886-2-2799-1355

User Manual
Version 2.00 March 2013

This document is the current official release manual. Please check CTC Union's website for any updated manual or contact us by E-mail at sales@ctcu.com. Please address any comments for improving this manual or to point out omissions or errors to marketing@ctcu.com. Thank you.

Table of Contents

Chapter 1 Introduction4
 1.1 Features 4
 1.2 Specification..... 5
 1.3 Applications..... 6
Chapter 2 Hardware Installation.....7
 2.1 Front Panel 7
 2.2 Rear Panel 10
 2.3 Installation 11
Appendix I12
Appendix II.....14

Chapter 1 Introduction



100M VDSL2 Ethernet Extender is a high-speed Ethernet Extender with one Ethernet port (RJ-45 connector) and one VDSL port (RJ-45 connector). It is a bridge mode modem, well accommodating VDSL2 (Very-high-data-rate Digital Subscriber Loop) technology to extend Ethernet service over single-pair phone line. It is compliant to ITU-T G.993.2 standard and supports VDSL2 30a profile that features 100Mbps of symmetric data rate over the existing copper wires. Supporting both symmetric and asymmetric transmission, it can reach up to 100/100 Mbps bandwidth (line rate) within 300M or 10/10 Mbps (line rate) for 1 Km long range connections. By providing ultra-high speed, the VDSL2 100M Ethernet Extender makes your telephone line achieve its best performance than before. It has the advantage of minimum installation time (simply as plug-n-play) and minimum expense by allowing video streaming and data to share the same telephone pair without interference.

100M VDSL2 Ethernet Extender delivers everything needed to quickly deploy a high-speed IP-based network for providing high-speed Internet access, video-on demand services and voice services. The resulting compact, cost-effective form factor offers Systems Integrators, small business owners an attractive Long Reach Ethernet solution.

1.1 Features

- Cost effective bridge function to connect two Ethernet LAN
- Support flow control on Fast Ethernet port via PAUSE frame or Back Pressure
- IEEE 802.1Q VLAN tag transparent
- Easy installation via simple plug-and-play
- Selectable CPE and CO mode via DIP switch:
 - Two working modes are built in the same unit, which keep the flexibility of installation and easy provision of service but lower inventory of service provider
- Selectable VDSL2 profile mode (17a or 30a):
 - Support up to VDSL2 30a profile to ensure high data rate.
- Selectable target band plan:
 - Symmetric: Support the band plan G.997 and provide the symmetric transmission on both downstream and upstream.
 - Asymmetric: Provides highest line rate in short range in asymmetric mode.
- Selectable target SNR margin
- Compatible with the 724M/708M DSLAM & third party DSLAM.
- Compatible with the 2U 19-inch, 17-slot chassis.

1.2 Specification

- **4-position DIP Switch**
 - Selectable CO or CPE mode
 - Selectable 30a or 17a (VDSL2 Profile)
 - Selectable Band plan (Symmetric or Asymmetric)
 - Selectable target SNR margin (6dB or 9dB)
- **LED:**
 - LAN: ACT/LNK, 10/100Mbps, Half/Full Duplex
 - VDSL: Power On/Off, CO/CPE, Idle/Trained/Link
- **Performance*** (AWG24 Wire)

Downstream/ Upstream	
17a Profile	
600M	42/46 Mbps
1000M	18/13 Mbps
1500M	12/3 Mbps
2000M	5/2 Mbps
30a Profile	
600M	40/45 Mbps
900M	22/19 Mbps
1200M	16/7 Mbps
1800M	8/2 Mbps
2100M	5/2 Mbps

- **LAN Interface:**
 - RJ-45 connector
 - Complying with IEEE 802.3/802.3u/802.3x
 - 10/100 Base-T Auto-Negotiation, Auto-MDI/MDI-X.
- **VDSL Interface:**
 - RJ-45 connector
 - DMT Encoding
 - Complying with ITU-T G993.1/993.2/G.997.1
 - On-board surge protection
- **Regulatory Compliance**
 - CE
 - FCC Part 15 Class B
 - EN60950
- **Power supply:**
 - DC single 12 Volt over 2.0 mm DC jack; 4.2 Watt maximum.
- **Dimension:** 73.4mm x 96.2mm x 22.8mm

*The above performance data is for reference only, the actual data rate may vary depending on the quality of the copper wire and environmental factors.

1.3 Applications

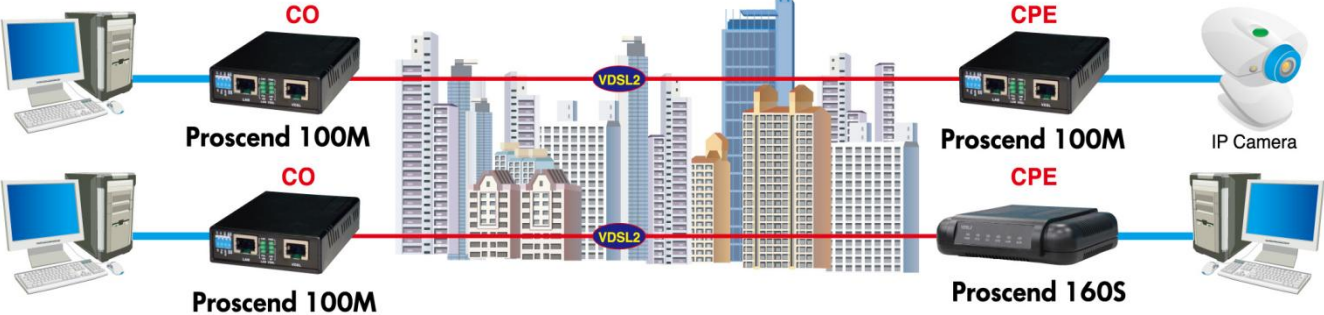

LAN Extender Application

Chapter 2 Hardware Installation

This chapter shows the front panel and how to install the hardware.

2.1 Front Panel

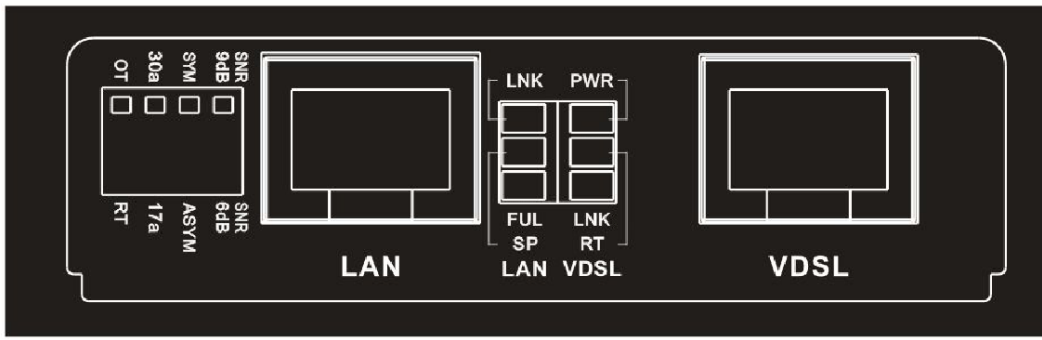

Front panel can be separated into five parts from left to right:

- (1) DIP switch
- (2) RJ-45 connector for Ethernet
- (3) LEDs for Ethernet
- (4) LEDs for VDSL
- (5) RJ-45 connector for VDSL

1. The RJ-45 is designed to connect to the Local Network with the Unshielded Twisted Pair (UTP) cable. The LEDs on top of RJ-45 connector show the status below:
- 2.

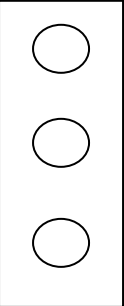
LEDs for LAN	✱ blinking	● On	○ Off
	Activity	Link UP	Link UP
		100Mbps	10Mbps
		Full Duplex	Half Duplex

LED	Color	Status	Descriptions
PWR(Power LED)	Green	On	Lights to indicate that the VDSL2 bridge had power
	Green	Off	The device is not ready or has malfunctioned.
LNK(Ethernet LED)	Green	On	The device has good Ethernet connection.
	Green	Blinking	The device is sending or receiving data.
	Green	Off	The LAN not connected.
LNK RT(VDSL Link)	Green	On	RT mode.
	Green	Blinking	Handshaking/Transmit & Received data
	Green	Off	The device not ready.
FUL 100(LAN Link)	Green	On	The device is link on 100M Full duplex and ready.
	Green	Blinking	The device is sending or receiving data.
	Green	Off	The device is link on 10M Full duplex and ready.

3. The following table describes the DIP Switches' setting.

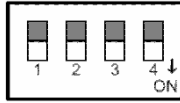

	Pin 1	Pin 2	Pin 3	Pin 4
	Side	Channel	Rate Limit	SNR
Off	OT	30a	Symmetric	9dB
On	RT	17a	Asymmetric	6dB

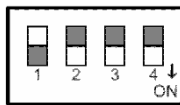

Pin 1: OT, RT switch

OT: LAN Extender acts as Central Office (CO) side.

RT: LAN Extender acts as Customer Premise Equipment (CPE) side.

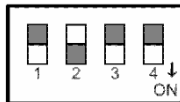

Pin 2: Impulse noise protection

30a: High Speed Mode. Provides communication protection for up to 250ms impulse noise with latency less than 6 ms.

17a: Long Reach Mode. Direct data transmission with latency less than 1 ms.

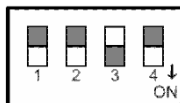

Pin 3: Band Plan

Symmetric: Support the band plan G.997 and provide the symmetric transmission on both downstream and upstream.

Asymmetric: Provides highest line rate in short range in asymmetric mode.

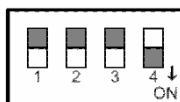

Pin 4: General protection

9dB: Better channel noise protection with SNR up to 9 dB

6dB: Original channel noise protection with 6 dB SNR.

4. The following table describes the LEDs' function of the product.

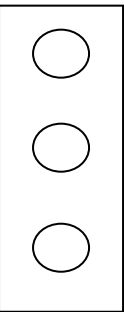
LEDs for VDSL	✱ blinking	● On	○ Off
		Device Power ON	Device Power OFF
		CPE -mode	CO -mode
	Slow: Idle Fast: Training	Linked	Off line

2.2 Rear Panel



The DC Jack on the rear panel can be connected to power supply adaptor with the DC input.

2.3 Installation

Please see the illustration below

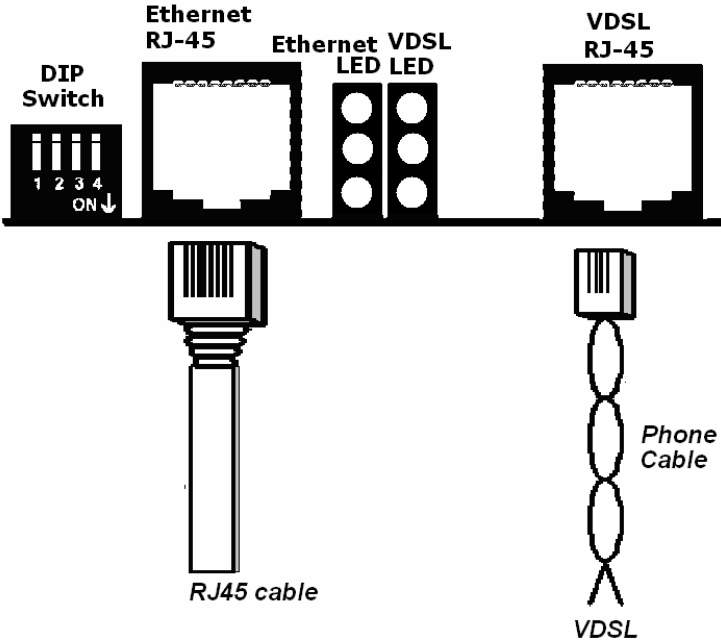

Appendix I

Connector Architecture

Ethernet Port Connector (RJ-45)

The Ethernet Port interface is an 8 position Modular Jack. The table below displays the pin out assignments.

Pin Number	Assignment (MDI-X)	Figure
1	RX+; Receive data +	
2	RX-; Receive data -	
3	TX+; Transmit data +	
4	Not used	
5	Not used	
6	TX-; Transmit Data -	
7	Not used	
8	Not used	

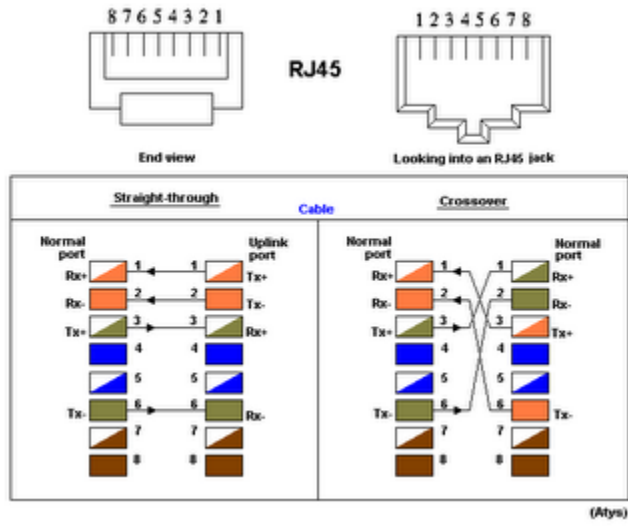

VDSL Interface Pin Assignments (RJ-45)

The VDSL interface is standard eight-pin modular jack. The table below displays the pin out assignments.

Pin Number	Description	Figure
1	Not used	
2	Not used	
3	Not used	
4	ANALOG Input/Output	
5	ANALOG Input/Output	
6	Not used	
7	Not used	
8	Not used	

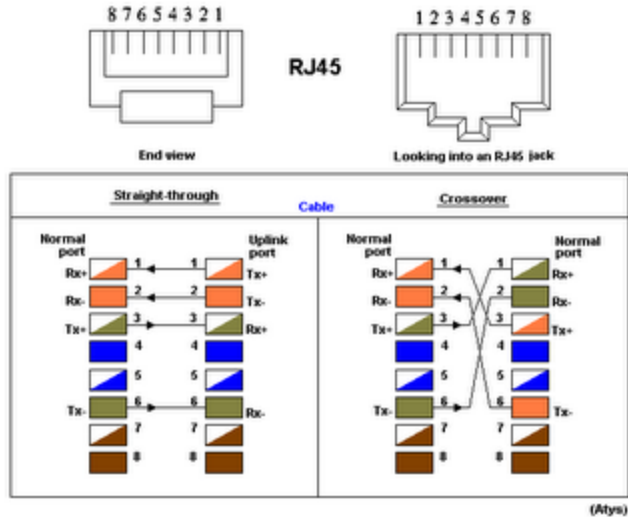

Appendix II

Chassis Accessory



There is also the Chassis solution for application on the rack in CO side. The major feature of the Chassis is listed below:

- 2U, 19", 17-Slot rack
- Support 17-slot in one unit
- Power Input: AC: 100 ~240V or DC48: 36 ~ 60V
- Cross flow cooling fan built-in
- 100M units are hot swappable

Specifications

- Power Input: AC : 100 ~240V or DC48 : 36 ~ 60V
- Power Consumption: >60W
- Dimensions: 76 X 212 X 88 mm (D x W x H)
- Weight: 7.9Kg
- Temperature: 0 ~ 50°C (Operating), -10 ~ 70°C (Storage)
- Humidity: 10 ~ 90% non-condensing
- Certification; CE, FCC, RoHS Compliant
- MTBF: 65,000 hrs

CTC[®]
union



www.ctcu.com

T +886-2 2659-1021 **F** +886-2 2659-0237 **E** sales@ctcu.com



ISO 9001 Quality System Certified CTC Union Technologies Co.,LTD.

All trademarks are the property of their respective owners. Technical information in this document is subject to change without notice.