

OLPS-RM-35

Optical Line Protection System 1:1

Features

- ◆ Reduces optical network downtime
- ◆ 1:1 optical protection with two active optical switches
- ◆ Completely transparent to network protocols
- ◆ Covers DWDM and CWDM wavelengths
- ◆ SNMP and console management
- ◆ 19" 1RU profile
- ◆ LCD display and key panel for direct local access
- ◆ Dual redundant power supplies



Applications

- ◆ Optical path protection for critical fiber transmission applications: works for any fiber protocol, including but not limited to Ethernet, SONET, SDH, Fibre Channel, SAN networks, etc.

Description

The Optical Line Protection System (OLPS) uses alternate optical fiber (secondary different route) to offer a backup path. By real-time monitoring of the power level of primary fiber circuit, the OLPS can automatically switch from main fiber to backup fiber when the power value gets lower than a user defined threshold. On the 1:1 protection systems there are two active optical switches for both Tx and Rx paths. In such way, the attenuation of the OLPS unit will be minimal. Alternative lower cost protections offer 1+1 systems that have a permanent splitter on the optical path and using a single active switch. Such systems can halve the optical budget available. The OLPS is a great tool for critical fiber optic networks, protecting backbones and crucial connectivity.

Functional OLPS operating block diagram

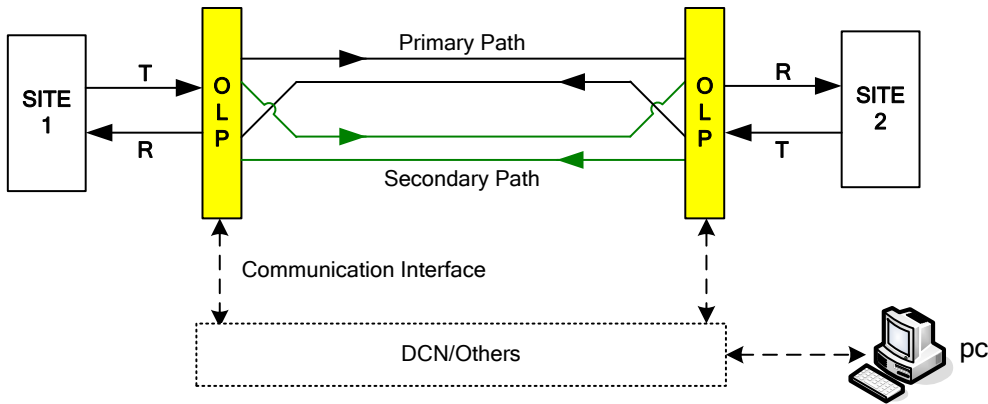

Operating Diagram for a 1:1 protection system

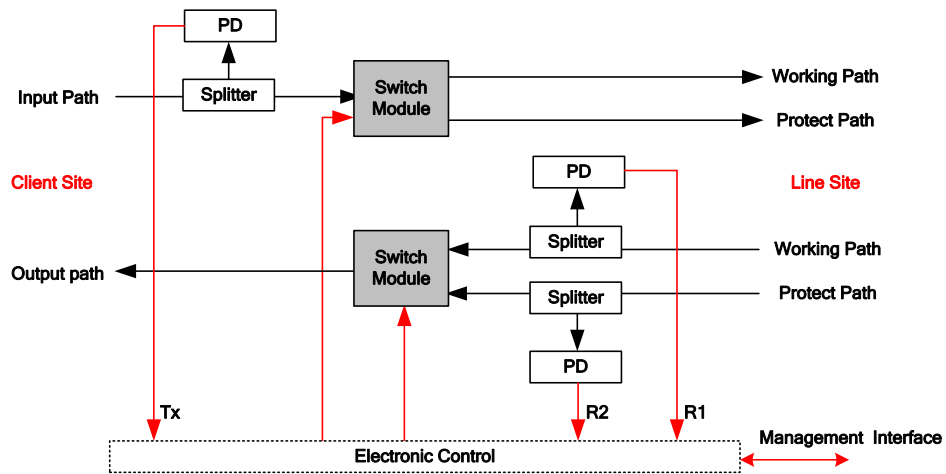

Specifications of the OLPS 1:1 system

OLPS-RM-35 series			
Parameter	Min	Max	Units
Operating wavelength	1260	1610	nm
Monitored optical power level	-50	23	dBm
Monitoring accuracy	-0.25	+0.25	dB
Monitoring resolution	-0.01	+0.01	dB
Return Loss	>55	-	dB
PDL	-	<0.05	dB
WDL	-	<0.1	dB
Insertion Loss	Tx<1.2	Rx<1.2	dB
Switching time	-	<35	ms
MTBF	60000	-	hrs
Operating temperature	-10	+60	°C
Storage temperature	-20	75	°C
Switching time	-	<35	ms
Power supply (AC)	90	240	V
Power supply (DC)	36	72	V

Ordering information

Part number	Operating Case temperature
OLPS-RM-35-AC	1:1 OLPS system, duplex path, 1RU, SC/UPC conn., IL<1.2db, single AC 90-240V
OLPS-RM-35-DC	1:1 OLPS system, duplex path, 1RU, SC/UPC conn., IL<1.2db, single DC 36-72V PS
OLPS-RM-35-AA	1:1 OLPS system, duplex path, 1RU, SC/UPC conn., IL<1.2db, dual AC 90-240V PS
OLPS-RM-35-DD	1:1 OLPS system, duplex path, 1RU, SC/UPC conn., IL<1.2db, dual DC 36-72V PS
OLPS-RM-35-AD	1:1 OLPS system, duplex path, 1RU, SC/UPC conn., IL<1.2db, one AC 90-240V and one DC 36~72V PS

E-mail: sales@robofiber.com