

IFS-402F
IFS-402F-E

Industrial Grade Fast Ethernet Switches



sales@ctcu.com

CTC Union Technologies Co., Ltd.
 Far Eastern Vienna Technology Center
 (Neihu Technology Park)
 8F, No. 60 Zhouzi St., Neihu District, Taipei 114
 Taiwan

T +886-2-26591021
 F +886-2-26590237
 E sales@ctcu.com

To download this QIG or a more complete user manual, please visit
<http://www.ctcu.com/Industrial/>



ISO 9001
 ISO 14001

©2013 CTC Union Technologies Co., Ltd.
 All trademarks are the property of their respective owners.
 Technical information in this document is subject to change without notice.

Introduction

IFS-402F/402F-E models are 4-port 10/100Base-T(X) Ethernet plus 2-port 100Base-FX switches that provide stable and reliable Ethernet transmission. Housed in rugged DIN rail or wall mountable enclosures, these switches are designed for harsh environments, such as industrial networking and intelligent transportation systems (ITS) and are also suitable for many military and utility market applications where environmental conditions exceed commercial product specifications. Standard operating temperature range models (0 to 60°C) and wide operating temperature range models (-40 to 75°C) fulfill the special needs of industrial automation applications.

Features

- Redundant dual DC inputs 12/24/48VDC
- IP30 rugged metal housing
- Wide temperature range -40~75C (IFS-402F-E)
- Industrial grade EMS certification
- DIP switch enable/disable broadcast storm filter
- UL508, CE, FCC, EN50121-4 Rail traffic

Specifications

Ethernet Interface

- Connector: RJ-45 (shielded)
- 4-ports
- Auto MDI/MDI-X
- Speed: 10/100Base-TX (Auto)
- Duplex: Full/Half (Auto-negotiation per IEEE802.3u)
- Supports IEEE802.3x Flow Control
- Store & Forward Switch
- Switching Fabric: 1.2Gbps
- Packet buffer: 448kb
- Packet size: 64~1536 bytes
- Standards: IEEE802.3, 802.3u, 802.3x
- 2K MAC table
- MTU: 64~1536 bytes
- Broadcast Storm protection (enable/disable by DIP)

Specifications (cont.)

Optical Ethernet Interface

- 100Base-FX, 2-ports
- Options for SC or ST connectors
- Multimode (2km) 50/125um, 62.5/125um
- Single mode (30 or 50km) 9/125um
- Wavelength: 1310nm (S/M or M/M)
- BiDi option (20km) for single mode, single fiber

Power

- Absolute range: 9.6~60VDC
- Reverse polarity protection: Yes
- Dual power inputs: Yes
- Connector: removable terminal block
- Consumption: 0.09A@48VDC, 4.32Watts

Mechanical

- Water & Dust Proof : IP30 Protection
- Dimensions : 106 x 39 x 142mm (D x W x H)
- Mounting : DIN-Rail, Wall Mount (kits included)
- Weight : 635 g

Environmental

- Operating Temperature :
 - 0°C ~ 60°C, -40°C ~ 75°C (wide temp. for *-E)
- Storage Temperature: -40°C ~ 85°C
- Humidity : 5 ~ 95% (non-condensing)

Certifications

- EMI: FCC Part 15 sub B class A, EN55022 Class A
- EMS: (Electromagnetic Susceptibility)
 - EN61000-4-2 (ESD) Level 3, Criteria B
 - EN61000-4-3 (RS) Level 3, Criteria A
 - EN61000-4-4 (Burst) Level 3, Criteria A
 - EN61000-4-5 (Surge) Level 3, Criteria B
 - EN61000-4-6 (CS) Level 3, Criteria A
 - EN61000-4-8 (Magnetic Field) Level 3, Criteria A
- Safety: UL508 (pending)
- Railway Traffic: EN50121-4
- Shock: EN60068-2-27 Freefall: EN60068-2-32
- Vibration: EN60068-2-6
- MTBF: 509883 hours

Connectors

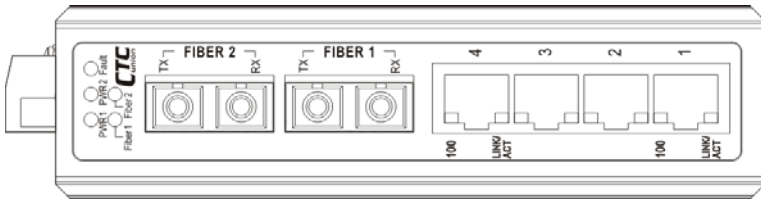

IFS-402F 4-port 10/100 plus 2-port Fiber Fast Ethernet switch

The 4-TP (twisted pair) LAN connections uses shielded RJ-45 which support Auto MDI/MDI-X, while the optical connections use SC or ST optical connections for multimode or single mode fiber depending on the model.

Power, Alarm and DIP switch

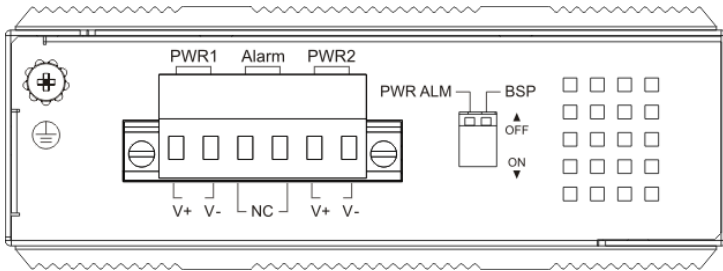

A removable terminal block provides both power and alarm connections. Power can be provided through the dual inputs from separate sources. One electrical relay can be wired into an alarm circuit. The relay is connected as Normally Closed (NC).

IFS-402F/402F-E uses a 2-pole DIP switch for configuration, with each pole of the switch having the following functions:

- PWR Alarm:** When 'On' this switch will disable alarm relay and LED if there is a power failure in one supply. If only connecting to a single power source, place this switch 'On' to disable alarm.
- BSP:** When 'On' this switch will disable the broadcast storm protection feature which is enabled by default.

LED Indicators

IFS-402F and IFS-402F-E have LEDs on the front face that report the condition of power, alarm, Fiber link, LAN link and speed.



PWR1: This green LED will light if power is connected and active at the PWR1 terminal connection.

PWR2: This green LED will light if power is connected and active at the PWR2 terminal connection.

Fault: This amber LED will light if one of the power inputs has fault condition and as long as DIP sw#1 is OFF.

Fiber 1: This green LED will light when the fiber 1 port has an optical link and will flash when there is Ethernet traffic.

Fiber 2: This green LED will light when the fiber 2 port has an optical link and will flash when there is Ethernet traffic.

100: This yellow LED will light when the LAN connected speed is 100M and will remain off if the connected speed is 10M.

LINK/ACT: This green LED will light when the LAN port has a link and will flash when there is Ethernet traffic.

Installation

IFS-402F/402F-E comes with both wall mount and DIN rail hardware brackets. When installing the DIN rail bracket, be sure to correctly align the orientation pin.

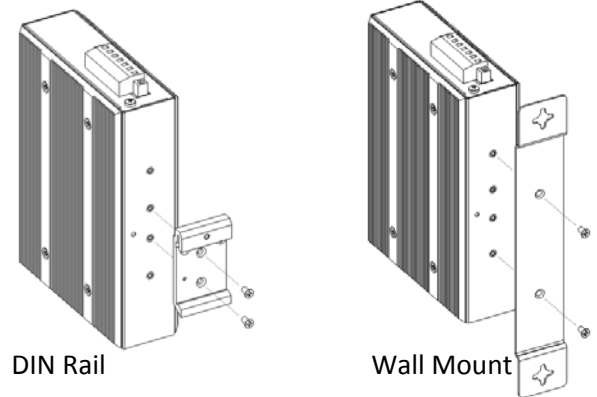

IFS-402F/402F-E with DIN Rail bracket has a steel spring in the upper rail of the bracket. This spring is compressed for mounting and un-mounting by applying downward force.

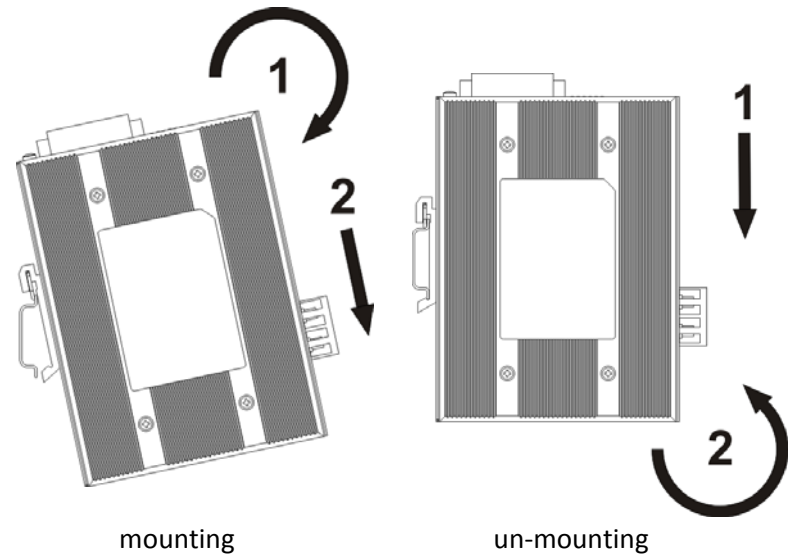

Notes:

