



H10-1204SM-S

12x 10/100/1000Base-Tx, 4x 1G/2.5G/10G SFP+
Layer 3 Managed Industrial Switch with SyncEthernet support

The H10-1204SM-S is a 16 port Gigabit/10G Ethernet managed Industrial Switch with 12x 10/100/1000Base-Tx and 4x 1G/2.5G/10G SFP+ ports, hardened for extreme operating temperatures: -40 to +75 Celsius. The Layer 3 managed switch supports a variety of Ethernet functions, including STP/RSTP/MSTP and multiple sub-Ring for redundant cabling, layer 2 Ethernet IGMP, VLAN, QoS, Security, bandwidth control, port mirroring and is housed in IP40 rated rugged metal housing designed to operate in difficult conditions, including mechanically and electrically extreme environments. The H10-1204SM-S model supports Time Sensitive Networks (Sync Ethernet), handling IEEE 1588v2 Precise Time Protocol, IEEE 802.1AS Time Synchronization, IEEE802.1Qbu Frame Preemption, IEEE 802.1Qbv Time Aware Shaper and IEEE 802.1CB Seamless Redundancy. Switch has strong surge protection: 4kV power supply and 2kV per RJ45 port.

Features

- DC power input block 9-56V and alarm relay 2A @24V DC
- Extreme operating temperature: -40 to +75 Celsius
- Rugged IP40 rated metal casing with DIN rail bracket
- 12x 10/100/1000Base-T RJ-45 and 4x 1G/2.5G/5G/10G SFP+ ports
- Reversed power polarity protection
- Supports RSTP/MSTP/ERPSv2/APS/MRP
- DHCP Server/Client/Relay/Snooping
- QoS, CoS, bandwidth control for Ingress and Egress, Storm Control
- Dynamic IEEE 802.3ad LACP Link Aggregation, Static Link Aggregation
- **IEEE 1588v2 PTP Precision Time Protocol and SyncE**
- **IEEE 802.1AS Time Synch, IEEE802.1Qbu Frame Preemption, IEEE 802.1Qbv Time Aware Shaper & IEEE 802.1CB Seamless Redundancy**
- Supports IEEE 802.1Q Tag VLAN and port VLAN
- IGMP snooping V1/V2/V3, IGMP Filtering/ Throttling, IGMP query
- Port based and MAC based IEEE802.1X, RADIUS, ACL
- Software upgrade via TFTP and HTTP
- Port mirroring, System log, DNS, SNTP, LLDP
- Web based management, SNMP v1/v2, Telnet
- Layer 3 functions supporting OSPFv2, OSPFv3, RIPv2 and Static Route

Specifications

IEEE Standard	IEEE 802.3 10Base-T Ethernet IEEE 802.3u 100Base-TX and 100Base-FX Fast Ethernet IEEE 802.3ab 1000Base-T and 1000Base-X Gigabit Eth. IEEE 802.3x Flow Control and Back Pressure
Switch Architecture	Back-plane (Switching Fabric): 64 Gbps
Data Processing	Store and Forward
Flow Control	IEEE 802.3x flow control, back pressure flow control
Provides Broadcast Storm Protection	Present
MAC Address Table	32K
Packet Buffer Size	32MB
Ports	12 x RJ-45 10/100/1000Base-Tx, 4 x 1G/2.5G/5G/10G SFP+ slots 10/100/1000Base-Tx auto negotiation speed, Auto MDI/MDI-X function, Full/Half duplex
Network Cable	10Base-T: 2-pair UTP/STP Cat.5 cable 100Base-TX: 2-pair UTP/STP Cat. 5 cable 1000Base-T: 4-pair UTP/STP Cat. 5e cable EIA/TIA-568 100-ohm (100m)
Protocols	CSMA/CD
LED	Per unit: PWR (Green) LNK/ACT (Green - Fiber port status and activity) Per port: Link/Active (Green), Speed/100 (Yellow)
Reverse Polarity Protection	Present
Overload Current Protection	Present
Power Supply	Redundant Dual DC 9V ~56VDC Input power (Removable Terminal Block)
Power Consumption	<39W at full load, <17W idle

Alarm Relay Contact	Relay outputs with current carrying capacity of 2 A @24VDC, NC
Removable Terminal Block	Provide 2 Redundant power, Alarm relay contact, 6 Pin
Operating Temperature	-40 ~ 75°C
Operating Humidity	5% to 95% (Non-condensing)
Storage Temperature	-40 ~ 85°C
Housing	Rugged Metal, IP40 Protection
Dimensions	160 x 70 x 132mm (D x W x H)
Weight	1.10kg
Installation Mounting	DIN Rail mounting or wall mounting
EMI	FCC Part 15 Subpart B Class A, CE EN 55022 Class A EN61000-6-4 – Emission for Industrial environment
EMS	EN61000-6-2 – Immunity for Industrial environment EN61000-4-2 (ESD) Level 3, Criteria B EN61000-4-3 (RS) Level 3, Criteria A EN61000-4-4 (Burst) Level 3, Criteria A EN61000-4-5 (Surge) Level 3, Criteria B EN61000-4-6 (CS) Level 3, Criteria A EN61000-4-8 (Magnetic Field) Level 3, Criteria A
Traffic control	NEMA-TS2
Rail Traffic	EN50121-4
Shock	IEC 60068-2-27
Freefall	IEC 60068-2-32
Vibration	IEC 60068-2-6
MTBF	120,000Hrs
Warranty	3 years

Software Specifications

Topology	
VLAN	IEEE 802.1q VLAN, up to 4094 802.1Q VLAN VID IEEE 802.1q VLAN, up to 4094 Groups IEEE 802.1ad Q-in-Q MAC-based VLAN, up to 256 entries
Link Aggregation (Port Trunk)	Static (Hash with SA, DA, IP, TCP/UDP port), up to 5 trunk Dynamic (IEEE 802.3ad LACP), up to 5 trunk group
Spanning Tree	IEEE802.1d STP IEEE802.1w RSTP IEEE802.1s MSTP
Multiple Ring	supports Sub-Ring type Recovery time <10ms The maximum number of devices allowed in a Ring supported ring is 250.
Loop Protection	Present
QoS Features	
Class of Service	IEEE802.1p 8 active priorities queues per port
Traffic Classification QoS	IEEE802.1p based CoS IP Precedence based CoS IP DSCP based CoS QCL(QoS Control List): Frame Type, Source/Destination MAC, VLAN ID, PCP, DEI QCE(QoS Control Entry): Protocol, Source IP, IP Fragment, DSCP, TCP/UDP port number
Bandwidth Control for Ingress	Rate in steps :1 kbps / Mbps Range : 100 kbps to 1Gbps Rate Unit : bit
Bandwidth Control for Egress	Rate in steps : 1 kbps / Mbps Range : 100 kbps to 1Gbps Rate Unit : bit Per queue / Per port shaper
Storm Control	for Unicast, Broadcast, Multicast

DHCP	Server, Client, Relay, Snooping
IP Source Guard	
Port Mirroring	
Event Syslog	Syslog server (RFC3164) (Support 1 server)
Warning Message	System log, alarm relay
DNS	Client, Proxy
NTP	
LLDP (IEEE802.1ab)	Link Layer Discovery Protocol LLDP-MED
IP Multicasting Features	
IGMP / MLD Snooping	IGMP Snooping v1, v2, v3 / MLD Snooping v1, v2 Port Filtering Profile Throttling, Fast Leave Maximum Multicast Group : up to 1022 entries Query / Static Router Port
Security Features	
IEEE 802.1X	Port-Based MAC-Based
ACL	Number of rules : up to 256 entries for L2 / L3 / L4
RADIUS authentication & accounting	
User Name	Local Authentication
Password	Remote Authentication (via RADIUS)
Authentication	
Management Interface Access	Web, Telnet / RS-232 console
Filtering	
Management Features	
Web Based Management, SNMP v1,v2, Console Telnet Server	
Secure mgmt	SNMP V3, TLSv1.2 and SSHv2
SW & Configuration Upgrade	TFTP, HTTP firmware upgrade function

Mobile Fronthaul Application

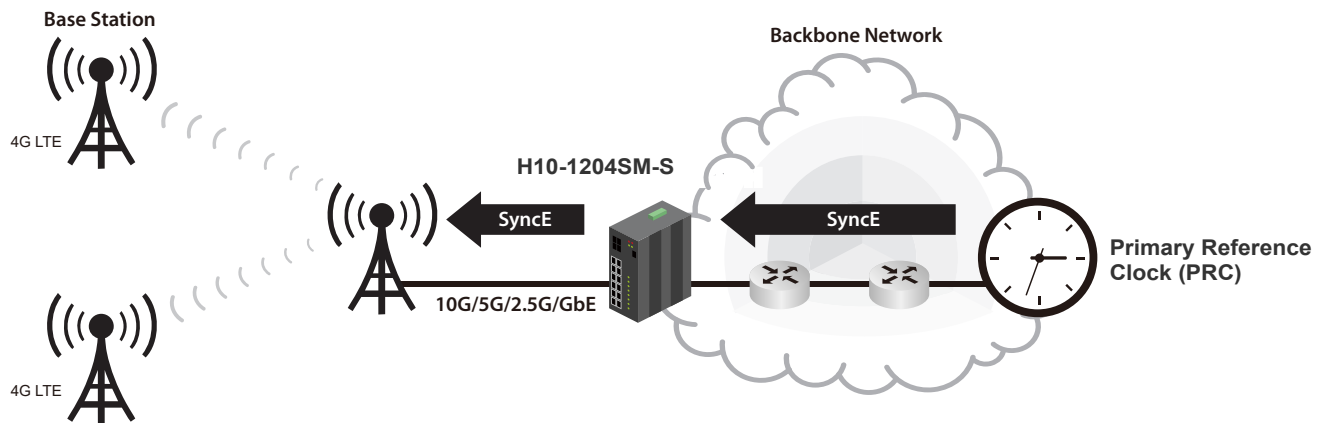

H10-1204SM-S Layer 3 Ethernet Managed Switch Application

Fiber Access Application

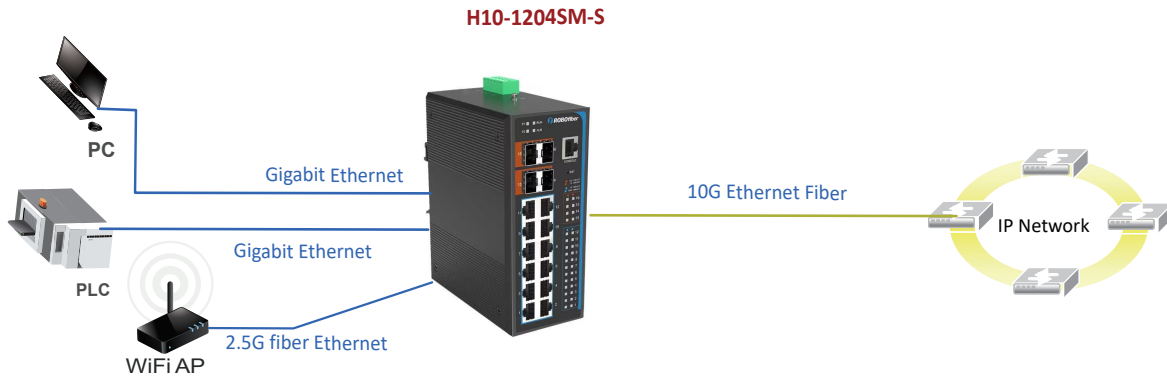

H10-1204SM-S 1G/2.5G/5G/10G Ethernet Layer 3 Managed Switch Application

Dimensions

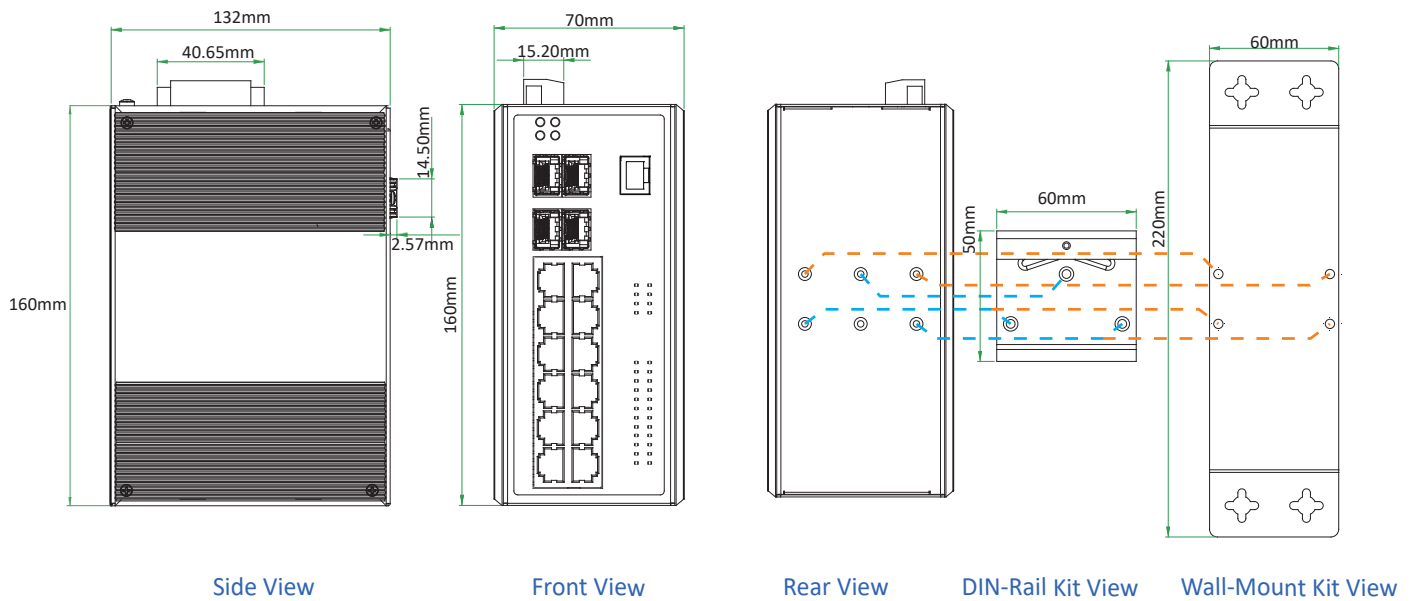

Ordering Information

Model Name	Description
H10-1204SM-PSE	12x 10/100/1000Base-Tx, 4x 1G/2.5G/5G/10G SFP+ Layer 3 Managed Industrial Switch Extreme Temp. (-40~75 Celsius), support for Sync-Ethernet and IEEE1588 PTP