

USER MANUAL

VDTU2A-301

VDSL2 LAN Extender



CTC
union

CTC Union Technologies Co.,

LEGAL

The information in this publication has been carefully checked and is believed to be entirely accurate at the time of publication. CTC Union Technologies assumes no responsibility, however, for possible errors or omissions, or for any consequences resulting from the use of the information contained herein. CTC Union Technologies reserves the right to make changes in its products or product specifications with the intent to improve function or design at any time and without notice and is not required to update this documentation to reflect such changes.

CTC Union Technologies makes no warranty, representation, or guarantee regarding the suitability of its products for any particular purpose, nor does CTC Union assume any liability arising out of the application or use of any product and specifically disclaims any and all liability, including without limitation any consequential or incidental damages.

CTC Union products are not designed, intended, or authorized for use in systems or applications intended to support or sustain life, or for any other application in which the failure of the product could create a situation where personal injury or death may occur. Should the Buyer purchase or use a CTC Union product for any such unintended or unauthorized application, the Buyer shall indemnify and hold CTC Union Technologies and its officers, employees, subsidiaries, affiliates, and distributors harmless against all claims, costs, damages, expenses, and reasonable attorney fees arising out of, either directly or indirectly, any claim of personal injury or death that may be associated with such unintended or unauthorized use, even if such claim alleges that CTC Union Technologies was negligent regarding the design or manufacture of said product.

TRADEMARKS

Microsoft is a registered trademark of Microsoft Corp.

HyperTerminal™ is a registered trademark of Hilgraeve Inc.

FCC WARNING:

This equipment has been tested and found to comply with the limits for a Class A digital device, pursuant to Part 15 of the FCC Rules. These limits are designed to provide reasonable protection against harmful interference when the equipment is operated in a commercial environment. This equipment generates, uses, and can radiate radio frequency energy and if not installed and used in accordance with the instruction manual may cause harmful interference in which case the user will be required to correct the interference at their own expense.

NOTICES:

- (1) The changes or modifications not expressly approved by the party responsible for compliance could void the user's authority to operate the equipment.
- (2) Shielded interface cables and AC power cord, if any, must be used in order to comply with the emission limits.
- (3) This is a Class A product. In a domestic environment this product may cause radio interference in which case the user may be required to take adequate measures.

CISPR PUB.22 Class A COMPLIANCE:

This device complies with EMC directive of the European Community and meets or exceeds the following technical standard. EN 55022 - Limits and Methods of Measurement of Radio Interference Characteristics of Information Technology Equipment. This device complies with CISPR Class A.

CE NOTICE

Marking by the symbol CE indicates compliance of this equipment to the EMC directive of the European Community. Such marking is indicative that this equipment meets or exceeds the following technical standards: EN 55022:1994/A1:1995/A2:1997 Class A and EN61000-3-2:1995, EN61000-3-3:1995 and EN50082-1:1997

CTC Union Technologies Co., Ltd.

Vienna Technology Center

8F, No. 60, Zhouzi St.,

Neihu District, Taipei, 114

Taiwan

VDTU2A-301 VDSL2 LAN Extender, Installation and Operation Manual

Version 1.0 April 2008

Firmware Version Notice: TBA

Table of Contents

| | |
|---------------------------------------|----|
| Tables of Contents..... | i |
| Chapter 1 Introduction..... | 7 |
| 1.1 Features | 7 |
| 1.2 Specification..... | 8 |
| 1.3 Applications | 8 |
| Chapter 2 Hardware Installation | 9 |
| 2.1 Front Panel | 9 |
| 2.2 Real Panel..... | 11 |
| 2.3 Installation..... | 11 |
| Appendix I..... | 13 |
| Connector Architecture | 13 |

Chapter 1. Introduction

Chapter 1. Introduction

CTC Union's VDTU2A-301 LAN Extender is a Long Reach Ethernet media converter with one Ethernet port (RJ-45 connector) and one VDSL port (RJ-45 connector) This model is a bridge mode modem, well accommodating VDSL2 (Very-high-data-rate Digital Subscribe Loop) technologies to extend Ethernet service over single-pair phone line. Supporting both symmetric and asymmetric transmission, it can reach up to 100/75 Mbps bandwidth (line rate) within 300M or 10/10 Mbps (line rate) for 1 Km long range connections. By providing ultra-high speed, VDTU2A-301 LAN Extender makes your telephone line achieve its best performance than before. It has the advantage of minimum installation time (simply as plug-n-play) and minimum expense by allowing video streaming and data to share the same telephone pair without interference.

1.1 Features

- Cost effective bridge function to connect two Ethernet LAN
- Support flow control on Fast Ethernet port via PAUSE frame or Back Pressure
- IEEE 802.1Q VLAN tag transparent
- Easy installation via simple plug-and-play
- Selectable CPE and CO mode via DIP switch:
Two working modes are built in the same unit, which keep the flexibility of installation and easy provision of service but lower inventory of service provider.
- Selectable fast and interleaved mode:
Fast mode guarantees a minimum end to end latency less than 1 ms. Interleaved mode provides impulse noises protection for any impulse noise with a duration less than 250 us, Interleaved mode has a maximum end to end latency of 10 m sec. Interleaved mode is the default mode.
- Selectable target data rate and target SNR margin:
User has the ability to select fixed SNR margin (9 dB) or fixed target data rate. When fixed SNR margin is selected, the systems will maintain the SNR margin at 9 dB across all usable loop length. When fixed target data rate is selected, the system will lock the data rate up to 50 Mbps/30 Mbps whenever the calculated SNR margin is higher than 9 dB. This gives best system stability and is the default mode.

Chapter 1. Introduction

1.2 Specification

- LAN Interface:
 - RJ-45 connector
 - Complying with IEEE 802.3/802.3u/802.3x
 - 10/100 Base-T Auto-Negotiation, Auto-MDI/MDI-X.
 - VDSL Interface:
 - RJ-45 connector
 - DMT Encoding
 - Complying with ITU-T G993.1/993.2
 - On-board surge protection
 - 4-position DIP Switch
 - LED:
 - LAN: ACT/LNK, 10/100 Mbps, Half/Full Duplex
 - VDSL: Power On/Off, CO/CPE, Idle/Trained/Link
 - Power supply:
 - DC single 12 Volt over 35mm DC jack
- Power consumption: 42 Watt maximum.

1.3 Applications

LAN Extender Application

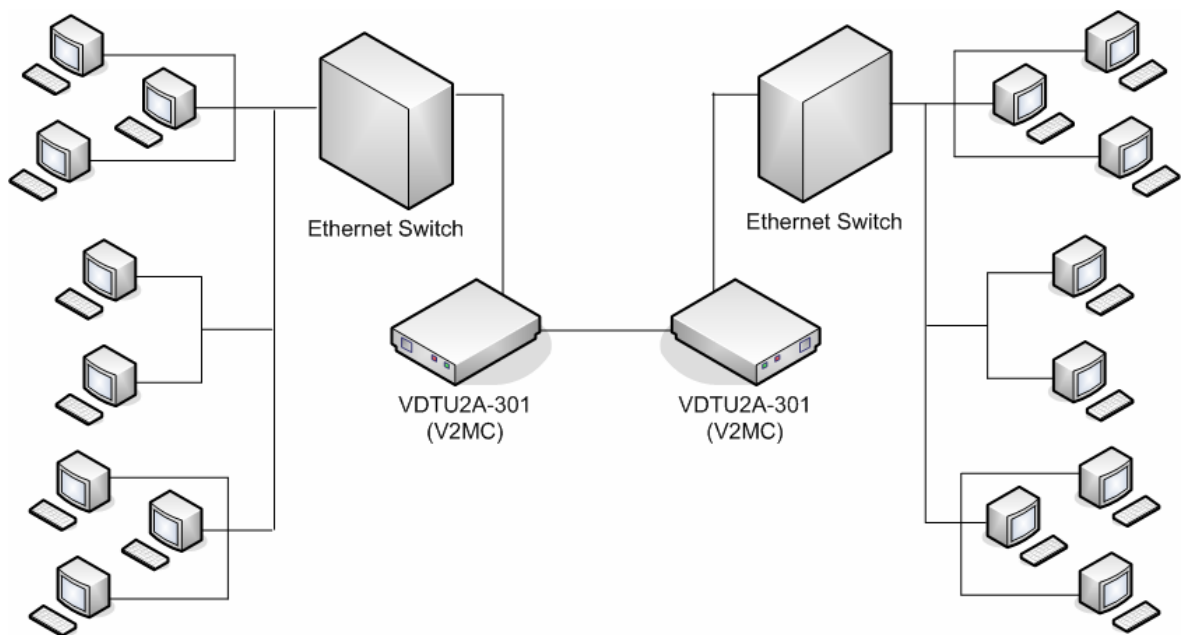

Chapter2. Hardware Installation

Chapter 2. Installation

This chapter shows the front panel and how to install the hardware.

2.1 Front Panel





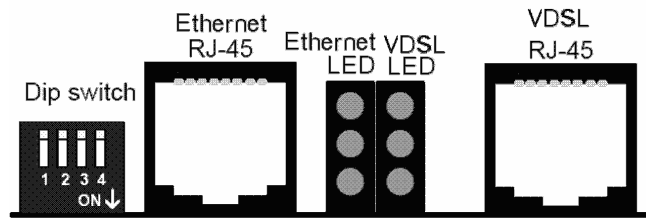

Please see the side view below configure 2.1:

Front panel can be separated into five parts from left to right:

- (1) DIP switch
- (2) RJ-45 connector for Ethernet
- (3) LEDs for Ethernet
- (4) LED for VDSL
- (5) RJ-45 connector for VDSL



1. The RJ-45 is designed to connect to the Local Network with the Unshielded Twisted Pair (UTP) cable. The LEDs on top of RJ-45 connector show the status below:

| LED for Ethernet |  |  |  |
|---|---|---|---|
| | Blinking | On | Off |
|  | Activity | Link UP | Link Down |
|  | | 100Mbps | 10Mbps |
|  | | Full Duplex | Half Duplex |

Chapter2. Hardware Installation

2. The following table describes the DIP Switchs' setting.



| | Pin 1 | Pin 2 | Pin 3 | Pin 4 |
|-----|-------|------------|------------|-------|
| | Side | Channel | Rate Limit | SNR |
| Off | CO | Interleave | Symmetric | 9dB |
| On | CPE | Fast | Asymmetric | 6dB |



Pin 1: CO, CPE switch

GO: LAN Extender acts as Central Office (CO) side.

GPE: LAN Extender acts as Customer Premise Equipment (CPE) side.



Pin 2: Impulse noise protection

Interleave mode: Provides communication protection for up to 250ms impulse noise with latency less than 6 ms.

Fast mode: Direct data transmission with latency less than 1 ms.



Pin 3: Band Plan

Symmetric: Support the band plan G.997 and provide the symmetric transmission on both down stream and upstream.

Asymmetric: Provides highest line rate in short range in asymmetric mode.





Pin 4: General protection

9dB: Better channel noise protection with SNR up to 9 dB

6dB: Original channel noise protection with 6 dB SNR.

Chapter2. Hardware Installation

3. The following table describes the LEDs' function of the product.

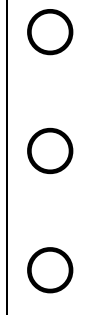
| | | | |
|---|--|---|---|
| LED for VDSL |  blinking |  On |  off |
|  | | Power ON | Power OFF |
| | | CPE-mode | CO-mode |
| | Slow: Idle Fast: Training | Linked | Off line |

2.2 Real Panel

The DC Jack on the rear panel can be connected to power supply adaptor with the DC input.

2.3 Installation

Please see the illustration below

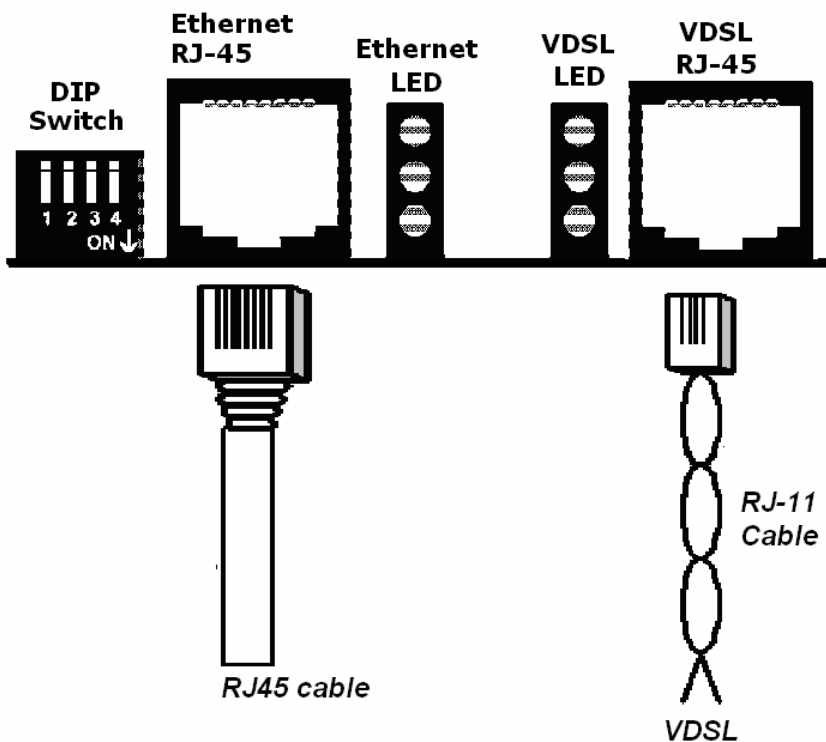

Appendix 1. Connector Architecture

Connector Architecture

Ethernet Port Connector (RJ-45)

The Ethernet Port interface is a 8 position Modular Jack. The table below displays the pin out assignments.

| Pin Number | Assignment (MDI-X) | Figure |
|------------|----------------------|--------|
| 1 | RX+; Receive data + | |
| 2 | RX-; Receive data - | |
| 3 | TX+; Transmit data + | |
| 4 | Not used | |
| 5 | Not used | |
| 6 | TX-; Transmit Data - | |
| 7 | Not used | |
| 8 | Not used | |

VDSL Interface Pin Assignments (RJ-45)

The VDSL interface is standard eight-pin modular jack. The table below displays the pin out assignments.

| Pin Number | Description | Figure |
|------------|---------------------|--------|
| 1 | Not used | |
| 2 | Not used | |
| 3 | Not used | |
| 4 | ANALOG Input/Output | |
| 5 | ANALOG Input/Output | |
| 6 | Not used | |
| 7 | Not used | |
| 8 | Not used | |

Appendix 1. Connector Architecture



Transmission Series

CTC Union Technologies Co., Ltd.

Vienna Technologies Center (Neihu Technology Park)

8F, 60 Zhouzi St., Neihu, Taipei, Taiwan 114

Phone:(886) 2.2659.1021 Fax:(886) 2.2799.1355

E-mail: info@ctcu.com <http://www.ctcu.com>