

User Manual



# SDH01A

STM-1 Based ADM  
Data, G.703 E1, LAN  
Add Drop Multiplexer



CTC UNION TECHNOLOGIES CO., LTD.



CTC Union Technologies Co., Ltd.  
Far Eastern Vienna Technology Center (Neihu Technology Park)  
8F, No. 60 Zhouzi St.  
Neihu District  
Taipei 114  
Taiwan  
Tel: +886-2-26591021  
Fax: +886-2-27991355  
Email: [info@ctcu.com](mailto:info@ctcu.com)  
URL: <http://www.ctcu.com>

## **SDH01A User Manual**

STM-1 Based ADM Multiplexer

Version 1.0 Aug 2008 (Release)

Copyright © 2008, CTC Union Technologies, Inc.  
All rights reserved.



All specifications are subject to change without prior notice.

## **Legal**

The information in this publication has been carefully checked and is believed to be entirely accurate at the time of publication. CTC Union Technologies assumes no responsibility, however, for possible errors or omissions, or for any consequences resulting from the use of the information contained herein. CTC Union Technologies reserves the right to make changes in its products or product specifications with the intent to improve function or design at any time and without notice and is not required to update this documentation to reflect such changes.

CTC Union Technologies makes no warranty, representation, or guarantee regarding the suitability of its products for any particular purpose, nor does CTC Union assume any liability arising out of the application or use of any product and specifically disclaims any and all liability, including without limitation any consequential or incidental damages.

CTC Union products are not designed, intended, or authorized for use in systems or applications intended to support or sustain life, or for any other application in which the failure of the product could create a situation where personal injury or death may occur. Should the Buyer purchase or use a CTC Union product for any such unintended or unauthorized application, the Buyer shall indemnify and hold CTC Union Technologies and its officers, employees, subsidiaries, affiliates, and distributors harmless against all claims, costs, damages, expenses, and reasonable attorney fees arising out of, either directly or indirectly, any claim of personal injury or death that may be associated with such unintended or unauthorized use, even if such claim alleges that CTC Union Technologies was negligent regarding the design or manufacture of said product.

## **TRADEMARKS**

Microsoft is a registered trademark of Microsoft Corp.

HyperTerminal™ is a registered trademark of Hilgraeve Inc.

## **WARNING:**

This equipment has been tested and found to comply with the limits for a Class A digital device, pursuant to Part 15 of the FCC Rules. These limits are designed to provide reasonable protection against harmful interference when the equipment is operated in a commercial environment. This equipment generates, uses, and can radiate radio frequency energy and if not installed and used in accordance with the instruction manual may cause harmful interference in which case the user will be required to correct the interference at his own expense. NOTICE: (1) The changes or modifications not expressly approved by the party responsible for compliance could void the user's authority to operate the equipment. (2) Shielded interface cables and AC power cord, if any, must be used in order to comply with the emission limits.

## **CISPR PUB.22 Class A COMPLIANCE:**

This device complies with EMC directive of the European Community and meets or exceeds the following technical standard. EN 55022 - Limits and Methods of Measurement of Radio Interference Characteristics of Information Technology Equipment. This device complies with CISPR Class A.

## **CE NOTICE**

Marking by the symbol CE indicates compliance of this equipment to the EMC and LVD directives of the European Community. Such marking is indicative that this equipment meets or exceeds the following technical standards: EN 55022:2006, Class A, EN55024:1998+A1:2001+A2:2003, and EN60950-1:2001

# Table of Contents

|  |           |
|--|-----------|
| <b>Chapter 1. Introduction</b>             | <b>7</b>  |
| 1.1 Functional Description                 | 7         |
| 1.2 System Features                        | 9         |
| 1.3 System Functional Blocks               | 10        |
| 1.4 Specifications                         | 11        |
| 1.4.1 Optical Interface                    | 11        |
| 1.4.2 E1 Interface                         | 11        |
| 1.4.3 Ethernet Interface                   | 12        |
| 1.4.4 V.35 Interface                       | 12        |
| 1.4.5 Management Interfaces                | 12        |
| 1.4.6 Connectors                           | 12        |
| 1.4.7 Electrical                           | 13        |
| 1.4.8 Physical                             | 13        |
| 1.4.9 LED Indicators                       | 13        |
| 1.4.10 Push Buttons                        | 13        |
| 1.4.11 LCD Display                         | 13        |
| 1.4.12 Office Alarm                        | 13        |
| 1.4.13 Environmental                       | 14        |
| <b>Chapter 2. System Applications</b>      | <b>15</b> |
| 2.1 Applications                           | 15        |
| 2.2 Services on Network                    | 16        |
| 2.3 EoS for E-LAN                          | 17        |
| <b>Chapter 3. Panels</b>                   | <b>21</b> |
| 3.1 Front View                             | 21        |
| 3.1.1 Tributary status LEDs                | 21        |
| 3.1.2 Alarm Indication LEDs                | 22        |
| 3.1.3 RJ-45 Ethernet Connector NMS         | 23        |
| 3.1.4 Console Interface                    | 23        |
| 3.1.5 Optical interface LED Indication     | 23        |
| 3.1.6 RESET Push Button                    | 24        |
| 3.1.7 ACO Push Button                      | 24        |
| 3.1.7 LCD Panel and Keypads                | 24        |
| 3.1.8 Alarm output Interface               | 24        |
| 3.2 Rear View                              | 25        |
| 3.2.1 Power Connection                     | 25        |
| 3.2.2 Frame Ground                         | 25        |
| 3.2.3 Electrical Power Switch              | 25        |
| 3.2.4 Tributaries Slots from 1 to 4        | 26        |
| 3.3 Tributary cards                        | 26        |
| 3.3.1 E1 interface                         | 26        |
| 3.3.2 Ethernet interface card              | 26        |
| 3.3.3 V35 interface card                   | 26        |
| <b>Chapter 4. Installation</b>             | <b>27</b> |
| 4.1 Install Equipment and Start the System | 27        |
| 4.1.1 Install AC Power                     | 27        |
| 4.1.2 Install DC Power                     | 27        |
| 4.1.3 Start the System                     | 27        |
| 4.2 Installation of Tributary Cards        | 27        |
| 4.3 Management Interface                   | 27        |
| 4.3.1 Console Interface                    | 27        |

|   |                                     |
|---|-------------------------------------|
| 4.3.2 NMS Interface .....                         | 27                                  |
| 4.4 Connect Cables .....                          | 28                                  |
| 4.4.1 Connect Fiber Cable.....                    | 28                                  |
| 4.4.2 Connect E1 Cable.....                       | 28                                  |
| 4.4.3 QSW Interface.....                          | 28                                  |
| 4.4.4 QV35 Interface .....                        | 28                                  |
| 4.5 Install Office Alarm .....                    | 28                                  |
| <b>Chapter 5. Module Description.....</b>         | <b>29</b>                           |
| 5.1 QE1B: 4 channel E1 module .....               | 29                                  |
| 5.2 8E1B: 8 channel E1 module.....                | 29                                  |
| 5.3 8E1R: 8 channel E1 module.....                | 29                                  |
| 5.4 QSW: 4 Port 10/100M Ethernet Module .....     | 29                                  |
| 5.5 QV35: 4 channel V.35 Module .....             | 29                                  |
| <b>Chapter 6. System Operations .....</b>         | <b>31</b>                           |
| 6.1 Start and Reset System .....                  | 31                                  |
| 6.1.1 Power Supply .....                          | 31                                  |
| 6.1.2 System Reset .....                          | 31                                  |
| 6.1.3 System Provisioning .....                   | 31                                  |
| 6.2 Performance Management.....                   | 33                                  |
| 6.3 Optical Interface Operation .....             | 33                                  |
| 6.4 Cross Connect and Mapping Table.....          | 34                                  |
| 6.5 Timing Synchronization.....                   | 35                                  |
| 6.6 Alarm Management.....                         | 35                                  |
| 6.7 Alarm Event Log.....                          | 36                                  |
| 6.8 E1 Interface Operation .....                  | 36                                  |
| 6.9 Time Interval Error (TIE) .....               | 36                                  |
| 6.10 Ethernet Transmission .....                  | 36                                  |
| 6.11 Maintenance and Self-Diagnostic Testing..... | 37                                  |
| 6.11.1 Loop back function .....                   | 37                                  |
| 6.11.2 Self Diagnostic Testing .....              | 37                                  |
| 6.12 Administration Security.....                 | 37                                  |
| 6.13 System Management.....                       | 37                                  |
| <b>Chapter 7. Network Management .....</b>        | <b>39</b>                           |
| 7.1 NMS Interface and SNMP .....                  | 39                                  |
| 7.2 NMS Functions .....                           | 40                                  |
| 7.3 Console Interface .....                       | 40                                  |
| 7.4 LCD Interface.....                            | 40                                  |
| <b>Appendix A. Ordering Information.....</b>      | <b>41</b>                           |
| <b>Appendix B. Menu-Driven Operations .....</b>   | <b>42</b>                           |
| I. Alarm Management .....                         | 43                                  |
| II. Performance Data .....                        | 45                                  |
| III. Configuration: .....                         | 48                                  |
| IV. Diagnosis Tools .....                         | 56                                  |
| V. System Settings .....                          | 59                                  |
| VI. Account Management .....                      | 63                                  |
| VII. Node Access.....                             | 65                                  |
| <b>Appendix C. LCD Operations .....</b>           | <b>66</b>                           |
| I. Operating Procedures: .....                    | 66                                  |
| II. Key Lock Protection:.....                     | 66                                  |
| III. The Function Menu List:.....                 | 67                                  |
| <b>Appendix D. Pin Assignments .....</b>          | <b>Error! Bookmark not defined.</b> |

### Chapter 1. Introduction

This chapter will introduce the SDH01A and describe its features, functions, and specifications.

#### 1.1 Functional Description

CTC Union's SDH01A, STM-1 Based Multi-Service Provisioning Platform, is an advanced compact Add Drop Multiplexer which can transmit up to 63 E1 and/or data service such as V35 and Ethernet. The optical interface complies with international telecommunication standards, such as ITU-T G.655, G.652, and G.653. By utilizing a modular design for aggregate and low speed tributaries, the SDH01A can meet your network demands with a flexible combination of services at a lower cost. All of the pluggable modules are designed to be hot swapped without any interruption to traffic when plugging in or out. In addition to the E1 tributaries (with G.704), other data interfaces are also provided for data communications such as V.35 and 10/100M Ethernet. Users can select any combination of modules according to their requirements. With this full function and multi-access capability, the SDH01A is your best choice for optical SDH networks.



Figure.1-1 SDH01A Outlook

The SDH01A provides three interfaces to manage the equipment. The first is a local LCD with keypad on the left front panel. The user can control and read the status of the system by LCD and keypad without any PC or terminal. This provides a convenient method for in-field configuration or support. The second management interface is via serial console port with RS-232 interface. The user can access the menu-driven interface to manage the system by connecting the console port to a VT-100 compatible terminal or PC with terminal emulation program, such as Windows® HyperTerminal™ or free third party emulation software such as PuTTY or TeraTerm. This operational interface will guide the user step by step with pull-down menus and pop-up windows. The user will quickly become familiar with this easy to use interface. The last management method is via the NMS interface. The physical layer of NMS interface is Ethernet and the NMS port implements SNMP protocol. SNMP is a standard network management protocol based on UDP. Since the Ethernet and SNMP are used widely, network managers can build up their network management system (NMS) using the proprietary MIBs (Management Information Base) provided by equipment vendors. The user can get many helpful resources during building of the NMS due to the general and universal nature of SNMP. Using the MIB can save expense and time while building the NMS. The user can even integrate the SDH01A into existing SNMP NMS by importing the MIB. In addition to the user's NMS, there is also a GUI NMS developed by CTC Union, based of the open source program OpenNMS, that can help you to remotely manage many SDH01As.

All three management interfaces described above support single-ended operation. That is, the operator can manage both the equipments at the local and remote sites through the local site at the same time. The communication between local equipment and remote equipments uses the DCC (data communications channel) to send message to implement the far end management. SDH01A provides administrative security by setting of user names and passwords to prevent the illegal operations of unauthorized users.

SDH01A provides auto alarm reports and office alarm relay contacts to inform user of any unusual or abnormal conditions in the equipment and system. As such, the user can easily identify the problem and recover the transmission network as quickly as possible. The alarms of the SDH01A are divided into 3 groups by their alarm conditions: critical alarms, major alarms, and minor alarms. The user can set the severity of all alarms of the SDH01A independently through console port, NMS port or LCD. All alarms can be used to activate the office alarms to inform the user that intervention is required. There are also LED indicators on the front panel of SDH01A for visual identification for field maintenance purpose. The LED indicators include power, system alarms, optical alarms, tributary alarms, remote alarm, local alarms, ACO status, loopback indication, and so on.

In addition to alarm reporting, the SDH01A implements performance monitoring (PM Parameters) to monitor the transmission quality on both the optical and electrical interfaces. The user can collect and analyze the performance data to determine the transmission quality. All the parameters can be read and cleared through the console port, NMS port or LCD.

Optical interface protection is important for any optical transmission system. The SDH01A is equipped with two optical modules to provide 1+1 auto protection switching (APS) of optical interface. The system will switch the optical interface from the working line to the protection line automatically when the working line fails due to loss of signal (LOS) or poor quality. The user can also perform manual switching from console, NMS or LCD management interfaces.

Synchronization is another important concern in synchronous optical networks. The SDH01A synchronization is obtained with a digital phase-locked loop circuit (DPLL), which provides timing and synchronization for the network. This helps to ensure system reliability by monitoring its reference clock for accuracy and stability and by maintaining stable output clocks during reference switching operations and during short periods when a clock reference is unavailable.

The SDH01A is an add drop multiplexer which is an important element of SDH (Synchronous Digital Hierarchy) optical fiber networks. The SDH01A has the capability to add one or more lower-bandwidth signals to the fiber's high-bandwidth data stream, and can extract or drop other low-bandwidth signals, removing them from the fiber and redirecting them to some other network path at the same time.

For system maintenance purposes, the SDH01A provides two functions: Loopback and Self Diagnostics. The user can operate the different types of loopback functions on the optical and E1 interfaces through console, NMS or LCD management interfaces to debug and identify the transmission problems on the network. By using the loopback function and built-in E1 PRBS<sup>-15</sup> signal generator and detector working together, the SDH01A can perform diagnostic testing for each E1 channel and determine the BER (Bit Error Rate).

The SDH01A is designed for easy installation. It can be mounted in a standard 19 or 23 inch EIA or ETSI rack. It can also be placed on desktop or shelf as a stand-alone unit. The SDH01A complies with FCC Part 15 Subpart B Rules of U.S./CISPR 22 Class A for EMI and EN50082-1 for EMC. It also complies with lightning surge protection standards for IEC1000-4-5 class 2, FCC part 68 and ITU-T K.20 / K.21 standards for E1 and AC / DC power.

### 1.2 System Features

- Up to 63 E1 (4, 8, 12, 16... 63) optical multiplexer per main board.
- Flexible add drop multiplexer with 63 available VC-12 resources.
- Up to 4 tributary cards per unit.
- System configurations are stored in NVRAM. Configurations are reloaded automatically when the tributary card is replaced or due to any other circumstances.
- Hot swap for each module without any interference to other working traffic when plugging in or out any module.
- Backup configurations in flash for system restart or power failure.
- Various services, such as E1, V.35 and 10/100M Ethernet. Ethernet traffic is encapsulated and transported over SDH using Generic Framing Procedure (GFP) & Virtual Concatenation (VCAT).
- E1 transparent transmission with HDB3/AMI line coding for E1. (The E1 parameters are field selectable through the management interface).
- EoS (Ethernet over SDH) for E-LAN. Supports Ethernet traffic in all nodes of rings.
- Single-ended network management.
- 1+1 APS for optical line and module (optional redundancy).
- Three timing synchronization modes.
- LED indicators: power, office alarm, optical alarm, tributary status, remote site alarm, loopback.
- LED indicator for remote site alarm.
- Office alarm relays.
- Many options for connectors, wavelength, and power budget for optical interface.
- Alarm auto report and performance monitoring.
- Administration security with login by username and password assigned by supervisor.
- Menu-driven and SNMP management interfaces.
- Provides summary report on menu-driven interface and LCD.
- Local and remote loop back functions for optical and E1 interfaces.
- Stand-alone and rack-mount in 19 or 23 inch EIA or ETSI rack.
- Two power sources: AC and DC. AC is the primary power supply.

## 1.3 System Functional Blocks

The block diagram of the SDH01A is as follows:

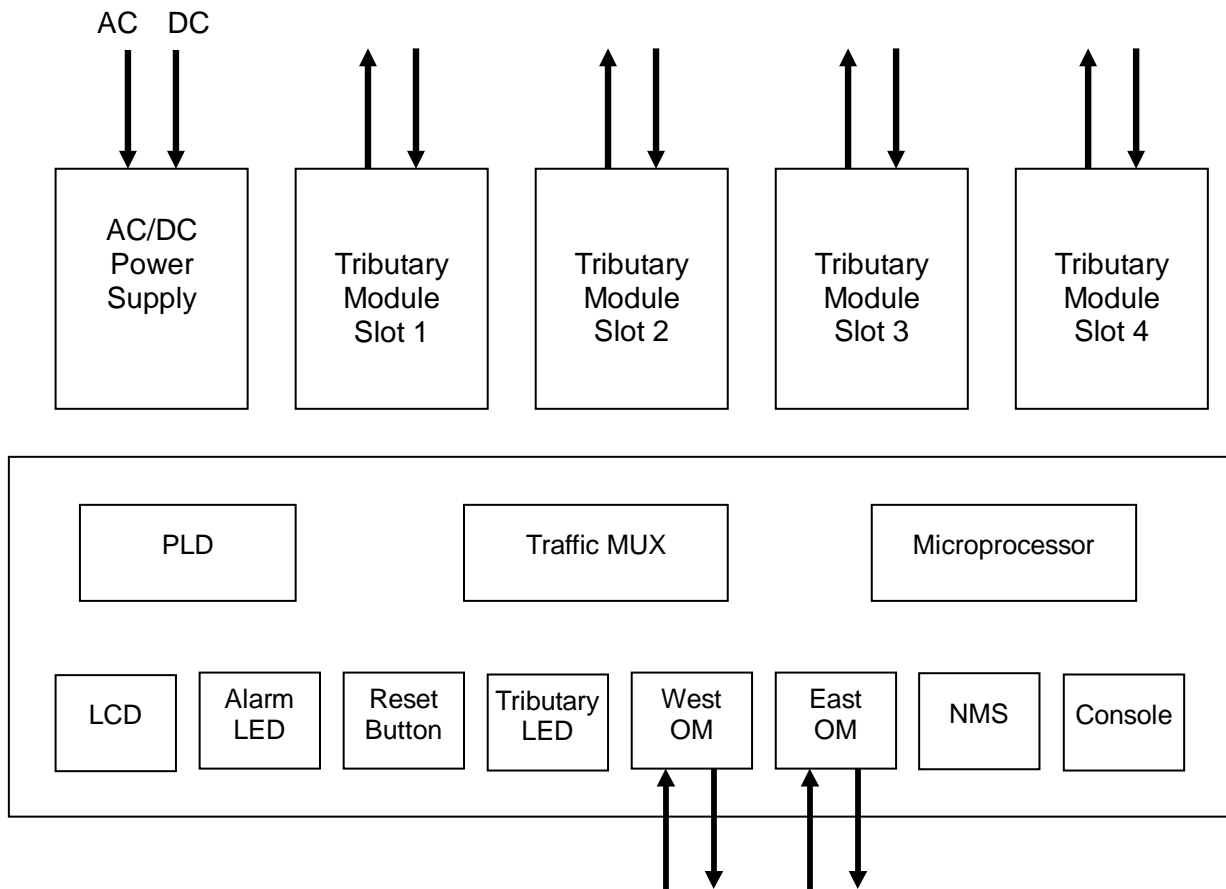

Figure 1-2 SDH01A Block diagram

The descriptions of the blocks presented in the Figure 1-2 are defined as follows:

- **LCD:** Manage system with 4 keypads and LCD panel.
- **Alarm LED:** Indicate the Alarm system status.
- **Reset Button:** Push to software reset the system.
- **Tributary LED:** Indicate status of the channels in the tributary modules.
- **OM:** optical signals convert for high speed aggregate, west and east sides.
- **NMS:** SNMP network management port with 10/100M Ethernet physical layer.
- **Console:** RS-232 port with menu-driven interface.
- **Microprocessor:** Provide OAM&P and control LED/LCD.
- **PLD:** This block provides the status of alarm and PM for microprocessor.
- **Traffic MUX:** This block implements the multiplexer/ de-multiplexer between low-speed and high-speed aggregate interfaces.
- **Tributary Module:** Each SDH01A provides 4 tributary slots for various types of modules, such as E1, V.35 and Ethernet.
- **AC/DC Power Supply:** Convert the 110V/220V AC or -48V DC to 12V DC power.

## 1.4 Specifications

### 1.4.1 Optical Interface

| Item                |       | Detail   |             |          |             |
|---------------------|-------|--|-------------|----------|-------------|
| Bit rate            |       | STM-1 155.52Mbps±20ppm                             |             |          |             |
| Compliance          |       | ITU-T G.707, G.841, G.783, G.803, G.652            |             |          |             |
| Source              |       | 1310nm/1550nm MM/SM                                |             |          |             |
| System gain         |       | 19dB (at $1 \times 10^{-10}$ BER) with AGC control |             |          |             |
| Switching time      |       | < 30ms   |             |          |             |
| Receive sensitivity |       | <-34dBm  |             |          |             |
| Connector type      |       | FC / SC / SC-WDM (BiDi)                            |             |          |             |
| Optical safety      |       | ALS, G.958, G.664                                  |             |          |             |
| Protection (option) |       | 1+1 APS  |             |          |             |
| Fiber mode          |       | Single mode fiber (G.652)                          |             |          |             |
| Wavelength          | Laser | Output Power                                       | Sensitivity | Distance | application |
| 1310                | FP    | -15 ~ -8 (dBm)                                     | -34 (dBm)   | 30 (km)  | S1.1        |
| 1310                | FP    | -5 ~ + 0 (dBm)                                     | -34 (dBm)   | 50 (km)  | L1.1        |
| 1550                | DFB   | -5 ~ + 0 (dBm)                                     | -34 (dBm)   | 80+ (km) | L1.2, L1.3  |

Table 1-1 Optical interface

### 1.4.2 E1 Interface

| Item                              | Detail  |
|-----------------------------------|---|
| Bit rate                          | 2.048Mbps±50ppm   |
| Line code                         | HDB3/AMI  |
| Compliance                        | ITU-T G.703, G.704, G.706, G.732, G.823   |
| Pulse Shape                       | Complies with ITU-T G.703   |
| Jitter                            | Complies with ITU-T G.823   |
| Impedance (connector)             | 75Ω± 5% (BNC/RJ-45)/ 120Ω± 5%(RJ-45)  |
| Line loss tolerance               | >6dB at 1024 KHz  |
| Minimum return loss at input port | 12dB for 51 to 102 KHz<br>18dB for 102 to 2048 KHz<br>14dB for 2048 to 3072 KHz |
| Performance                       | ITU G.821/G.826   |

Table 1-2 E1 Interface

## 1.4.3 Ethernet Interface

| Item       | Detail  |
|------------|---|
| Data rate  | 10/100 Mbps with auto negotiation   |
| Mode       | L2 Switch, 100Mbps throughput   |
| Compliance | ITU-T G.7041 GFP-F, G.707 VCAT, IEEE 802.3x, 802.1d, 802.1w, 802.1p, 802.1q (Q-in-Q), 802.3ad |
| Connector  | RJ-45 x 4   |

Table 1-3 Ethernet Interface

## 1.4.4 V.35 Interface

| Item           | Detail                              |
|----------------|-------------------------------------|
| Data rate      | Nx64Kbps (N=1 to 32)                |
| Clock Source   | External, Internal or Recovery      |
| Compliance     | ITU-T V.35, ITU-T G.703             |
| Connector      | DB-44 (DB-44 to MB34 adapter cable) |
| Control Signal | DSR, CTS, DCD                       |

Table 1-4 V.35 Interface

## 1.4.5 Management Interfaces

| Item            | Detail                              |
|-----------------|-------------------------------------|
| Protocol        | VT-100 ANSI and SNMP (EMS)          |
| Craft interface | RS-232 Async. (EIA561)              |
| SNMP            | 10/100 Base-T (RFC 1406)            |
| LCD             | 2 X 16 LCD display with key control |

Table 1-5 Management Interfaces

## 1.4.6 Connectors

| Item         | Detail                              |
|--------------|-------------------------------------|
| Optic        | SC/FC/SC-WDM (BiDi)                 |
| E1           | BNC or RJ-45 (USOC RJ-48C)          |
| V.35         | DB-44 (DB-44 to MB34 adapter cable) |
| RS-232       | D-type 9-pin female                 |
| LAN          | RJ-45                               |
| Office alarm | D-type 9-pin male                   |
| AC power     | IEC C14 type                        |
| DC power     | Screw terminal                      |
| Frame Ground | Screw terminal                      |

Table 1-6 Connectors

## 1.4.7 Electrical

| Item              | Detail               |
|-------------------|----------------------|
| DC input          | -36 ~ -72V           |
| AC input          | 90~264Volt @ 44~63Hz |
| Power consumption | <15W                 |

Table 1-7 Electrical Power Source

## 1.4.8 Physical

| Item   | Detail   |
|--------|--|
| Height | 44mm (1.75 in.) (1U, Mount in 19"/23"/ETSI rack) |
| Width  | 440mm (17 9/32 in.)                              |
| Depth  | 312mm, (12 21/64 in)                             |
| Weight | 3.6Kg (~8 lb.)                                   |

Table 1-8 Physical Parameters

## 1.4.9 LED Indicators

Front panel

- WK-working line indicator for each optical module
- FLT-Fault indicator for each optical module
- Alarm indicator: CRT-critical, MJR-major , MNR-minor
- ACO-Alarm Cut Off indicator
- PWR-power indicator
- RDI-remote defect (alarm) indicator
- MNT-loopback status indicator
- Tributary Status-16 channels status indicators
- Ethernet status indicators (10/100 Mbps)
- V.35 status indicators

## 1.4.10 Push Buttons

- ESC/ENT+/←/→ LCD control keypads
- ACO-alarm cut off
- RST-reset system

## 1.4.11 LCD Display

- 2x16 liquid crystal display

## 1.4.12 Office Alarm

- Visible-critical, major, and minor alarms

### 1.4.13 Environmental

| Item        | Detail   |
|-------------|--|
| Temperature | -10~65°C 15~150° F                             |
| Humidity    | from 0% to 100% (100% at 30°C, non-condensing) |
| EMI         | FCC part15 sub B /CISPR 22 class A             |
| MTBF        | >50, 000hrs                                    |
| MTTR        | 7 days   |

Table 1-9 Environmental Conditions

## Chapter 2. System Applications

This chapter describes the topology application of the SDH01A and its services on the network.

### 2.1 Applications

The basic applications for SDH01A are as a TM (terminal multiplexer) between two end points, such as central office and remote customer or as an ADM (add drop multiplexer), i.e. in an SDH ring structure.



Figure 2-1 Terminal Multiplexer (TM) application

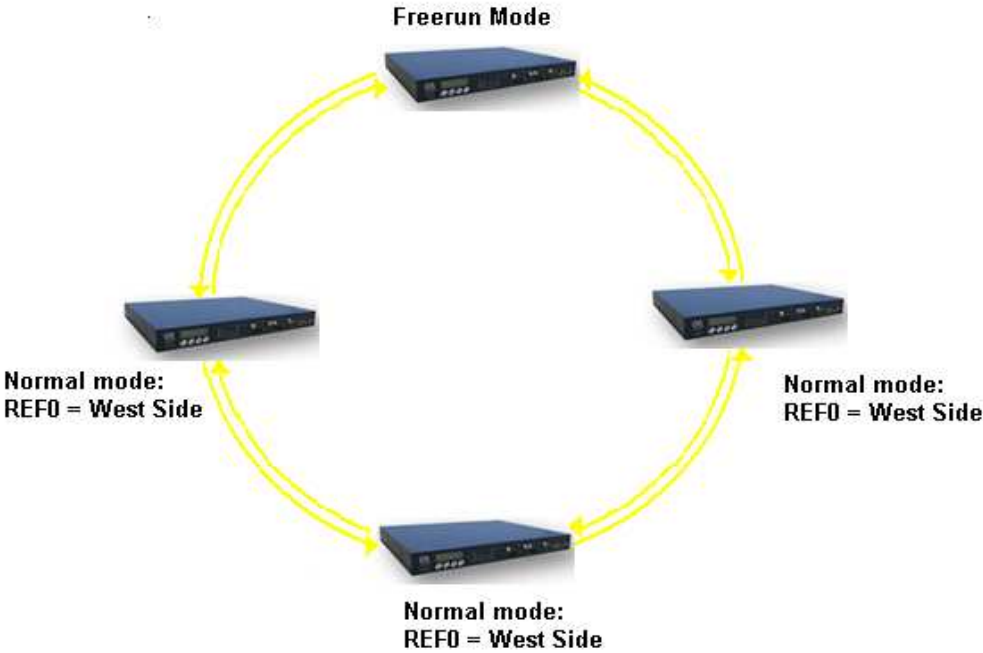

Figure 2-2 Add Drop Multiplexer (ADM) application

2.2 Services on Network

The SDH01A can transmit up to 63 E1 signals with another SDH01A (or other combinations with data services like V.35/Ethernet) over fiber. It can be applied to various types of networks, such as optical network, MSTP network, mobile network, PSTN network, and leased line to provide voice, data, and video services for high quality and long transmission distance. It can be used either with one fiber link or two fiber links, utilizing one for a back up link. It is suitable for central office and customer premise/office for exchange data communications.

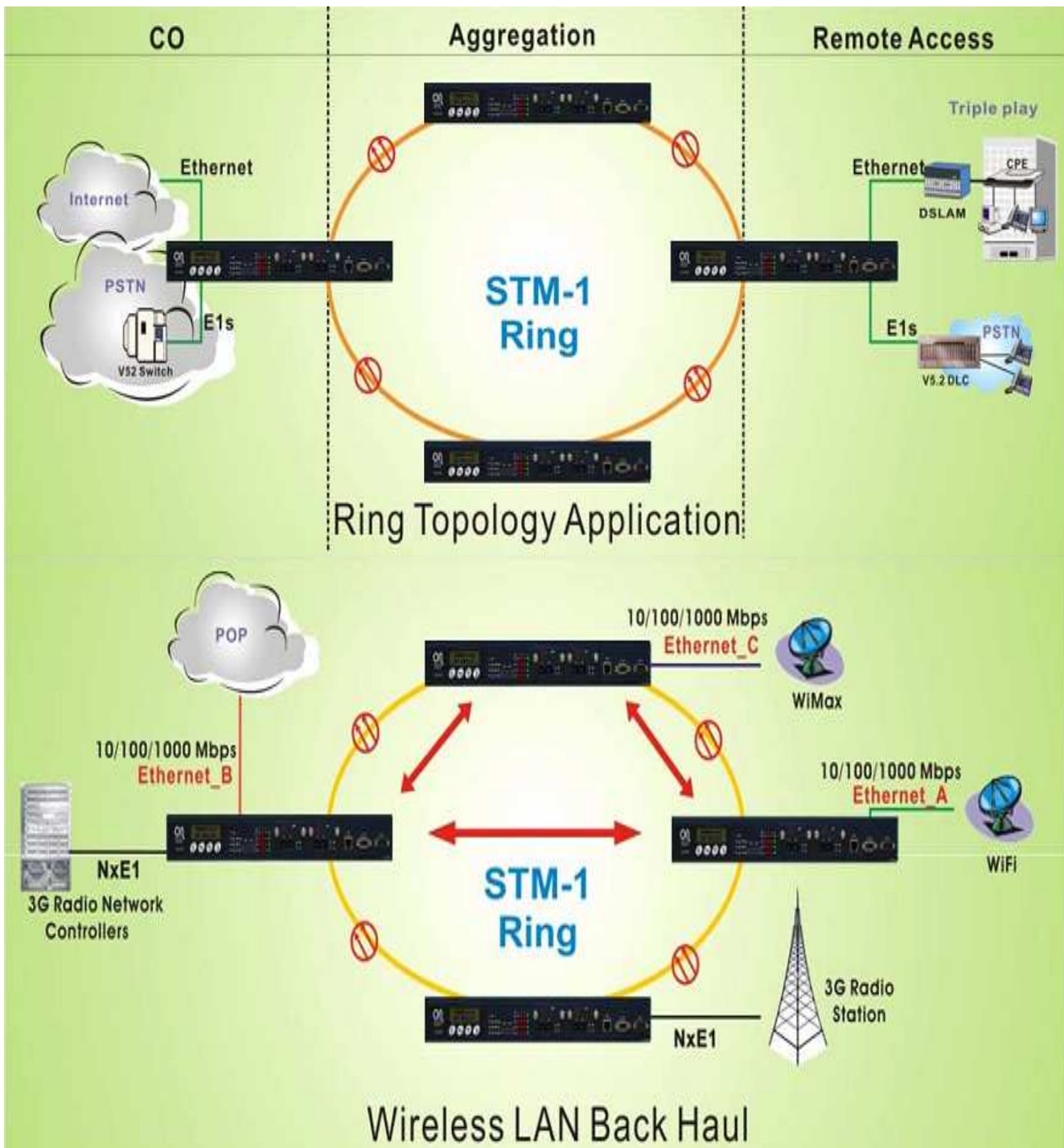

Figure 2-3 Network application

The SDH01A can provide cross connect for TDM services. It is easy to set up the 63x63 cross connection in the CLI to let V.35 map to E1, or any E1 channel map to the different E1 channel as follows.

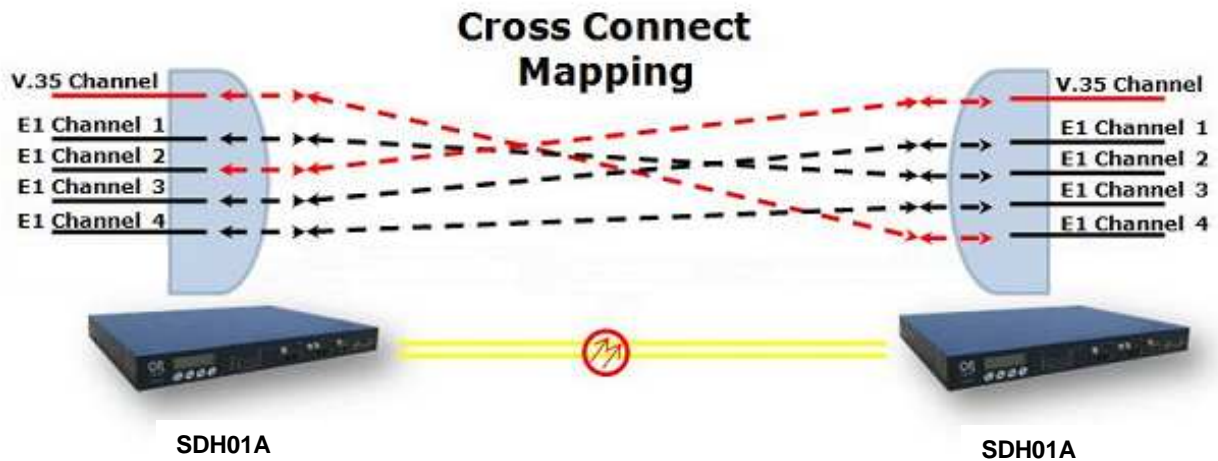

Figure 2-4 Cross Connect Mapping

### 2.3 EoS for E-LAN

With EoS (Ethernet over SDH) it is possible to have Ethernet communications between all nodes for E-LAN application. As the following figure shows, nodes A, B, C and D are able to communicate between each other freely.

Ethernet traffic and TDM traffic have different protection switching mechanism. TDM Traffic travels in both directions (UPSR), while Ethernet Traffic travels in one ring direction, e.g the case where outer ring (Black line) is primary path and inner ring (Gray line) is for protection (Gray line).

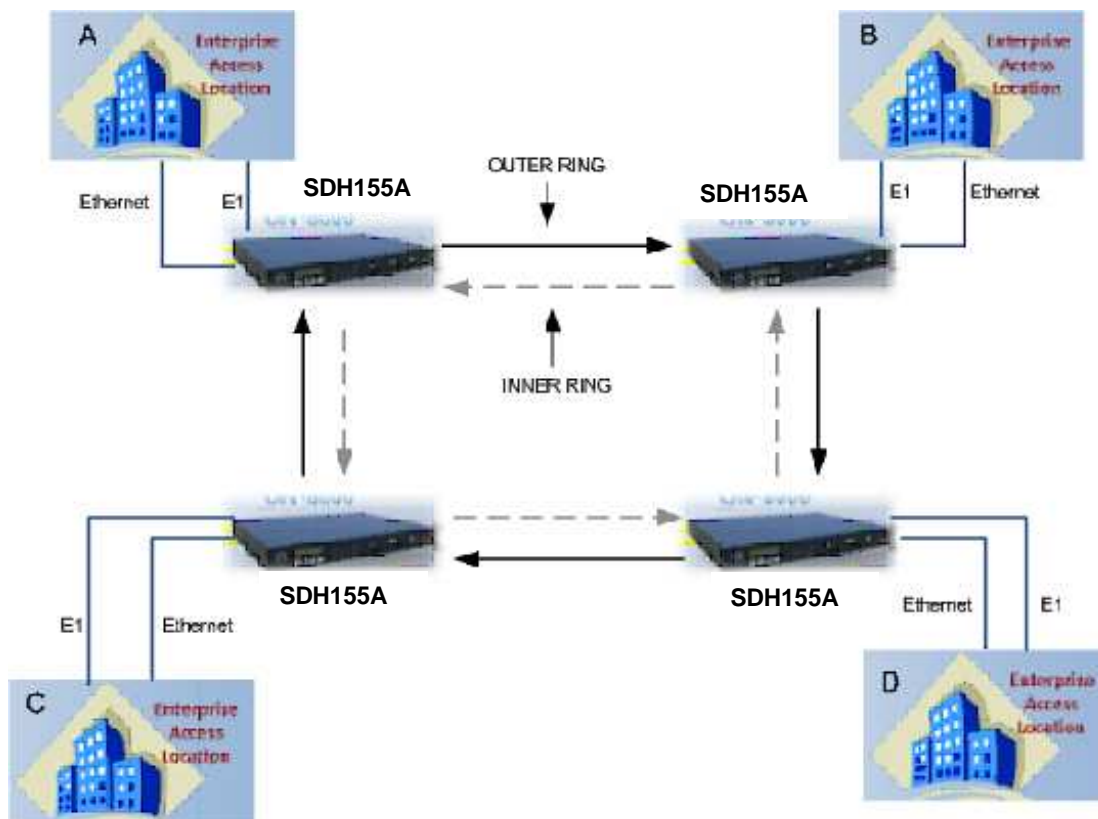

Figure 2-5 EoS (Ethernet over SDH) ring protection scheme

## Chapter 2. Applications

Referring to Figure 2-5, EoS configuration is done in the cross-connect table to assign the VC12s. GFP (Ethernet traffic) shares the same VC12s in all nodes. For example, let's configure a ring with 4 nodes sharing 100Mbps (47 VC12s) of Ethernet traffic and two TDM channels between node A and C (Ch 1 and 2), and two different TDM channels between node B and D (Ch 8 and 9).

Cross-connect table for node A and node C. Channels 1 & 2 connect 2x2M E1 while 47 VC12s are assigned to GFP from channel 17 to channel 63:

```

<< Digital Cross Connect Table >>
CH: K L M      CH: K L M      CH: K L M      CH: K L M
1 [1 1 1] T-S1P1 17 [2 6 1] GFP-G1 33 [3 4 2] GFP-G1 49 [1 3 3] GFP-G1
2 [2 1 1] T-S1P2 18 [3 6 1] GFP-G1 34 [1 5 2] GFP-G1 50 [2 3 3] GFP-G1
3 [3 1 1]      19 [1 7 1] GFP-G1 35 [2 5 2] GFP-G1 51 [3 3 3] GFP-G1
4 [1 2 1] ----- 20 [2 7 1] GFP-G1 36 [3 5 2] GFP-G1 52 [1 4 3] GFP-G1
5 [2 2 1] ----- 21 [3 7 1] GFP-G1 37 [1 6 2] GFP-G1 53 [2 4 3] GFP-G1
6 [3 2 1] ----- 22 [1 1 2] GFP-G1 38 [2 6 2] GFP-G1 54 [3 4 3] GFP-G1
7 [1 3 1] ----- 23 [2 1 2] GFP-G1 39 [3 6 2] GFP-G1 55 [1 5 3] GFP-G1
8 [2 3 1] ----- 24 [3 1 2] GFP-G1 40 [1 7 2] GFP-G1 56 [2 5 3] GFP-G1
9 [3 3 1] ----- 25 [1 2 2] GFP-G1 41 [2 7 2] GFP-G1 57 [3 5 3] GFP-G1
10 [1 4 1] ----- 26 [2 2 2] GFP-G1 42 [3 7 2] GFP-G1 58 [1 6 3] GFP-G1
11 [2 4 1] ----- 27 [3 2 2] GFP-G1 43 [1 1 3] GFP-G1 59 [2 6 3] GFP-G1
12 [3 4 1] ----- 28 [1 3 2] GFP-G1 44 [2 1 3] GFP-G1 60 [3 6 3] GFP-G1
13 [1 5 1] ----- 29 [2 3 2] GFP-G1 45 [3 1 3] GFP-G1 61 [1 7 3] GFP-G1
14 [2 5 1] ----- 30 [3 3 2] GFP-G1 46 [1 2 3] GFP-G1 62 [2 7 3] GFP-G1
15 [3 5 1] ----- 31 [1 4 2] GFP-G1 47 [2 2 3] GFP-G1 63 [3 7 3] GFP-G1
16 [1 6 1] ----- 32 [2 4 2] GFP-G1 48 [3 2 3] GFP-G1 T-S?P? TDM traffic

Press 'r': refresh, 'c/d': clean/remove, 'l': default, 's': save, 'Esc': exit

```

Cross-connect table for node B and node D. Channels 8 & 9 connect 2x2M E1 while 47 VC12s are assigned to GFP from channel 17 to channel 63:

```

<< Digital Cross Connect Table >>
CH: K L M      CH: K L M      CH: K L M      CH: K L M
1 [1 1 1] ----- 17 [2 6 1] GFP-G1 33 [3 4 2] GFP-G1 49 [1 3 3] GFP-G1
2 [2 1 1] ----- 18 [3 6 1] GFP-G1 34 [1 5 2] GFP-G1 50 [2 3 3] GFP-G1
3 [3 1 1] ----- 19 [1 7 1] GFP-G1 35 [2 5 2] GFP-G1 51 [3 3 3] GFP-G1
4 [1 2 1] ----- 20 [2 7 1] GFP-G1 36 [3 5 2] GFP-G1 52 [1 4 3] GFP-G1
5 [2 2 1] ----- 21 [3 7 1] GFP-G1 37 [1 6 2] GFP-G1 53 [2 4 3] GFP-G1
6 [3 2 1] ----- 22 [1 1 2] GFP-G1 38 [2 6 2] GFP-G1 54 [3 4 3] GFP-G1
7 [1 3 1] ----- 23 [2 1 2] GFP-G1 39 [3 6 2] GFP-G1 55 [1 5 3] GFP-G1
8 [2 3 1] T-S2P1 24 [3 1 2] GFP-G1 40 [1 7 2] GFP-G1 56 [2 5 3] GFP-G1
9 [3 3 1] T-S2P2 25 [1 2 2] GFP-G1 41 [2 7 2] GFP-G1 57 [3 5 3] GFP-G1
10 [1 4 1] ----- 26 [2 2 2] GFP-G1 42 [3 7 2] GFP-G1 58 [1 6 3] GFP-G1
11 [2 4 1] ----- 27 [3 2 2] GFP-G1 43 [1 1 3] GFP-G1 59 [2 6 3] GFP-G1
12 [3 4 1] ----- 28 [1 3 2] GFP-G1 44 [2 1 3] GFP-G1 60 [3 6 3] GFP-G1
13 [1 5 1] ----- 29 [2 3 2] GFP-G1 45 [3 1 3] GFP-G1 61 [1 7 3] GFP-G1
14 [2 5 1] ----- 30 [3 3 2] GFP-G1 46 [1 2 3] GFP-G1 62 [2 7 3] GFP-G1
15 [3 5 1] ----- 31 [1 4 2] GFP-G1 47 [2 2 3] GFP-G1 63 [3 7 3] GFP-G1
16 [1 6 1] ----- 32 [2 4 2] GFP-G1 48 [3 2 3] GFP-G1 T-S?P? TDM traffic

Press 'r': refresh, 'c/d': clean/remove, 'l': default, 's': save, 'Esc': exit

```

In this example, the 4 nodes share an Ethernet bandwidth of 100Mbps (47 VC12s).

It's still possible to have more control over the Ethernet bandwidth requirements for each node and port using "Egress rate" and "Ingress rate" configurations on the QSW (Quad Ethernet Switch) module.

|                             |                 |                              |                    |
|-----------------------------|-----------------|------------------------------|--------------------|
| <b>** Detected **</b>       |                 | Apply to .....               | Current            |
| <b>S-4 - QSW</b>            |                 | Apply to Port.....           | 1                  |
|                             |                 | Service State.....           | In Service         |
|                             |                 | Link Control.....            | Auto-Negotiation   |
| Flow Control.....           | <b>Disable</b>  | Ingress Rate.....            | Enable             |
| Default Priority.....       | 0               | Rate.....                    | 30M                |
| Double VLAN Tag.....        | Disable         | <del>Flow Control.....</del> | <del>Disable</del> |
| Provider Tag.....           | 0000.           | Unknown Unicast....          | limit              |
| Default VLAN ID.....        | 0000.           | Unknown Broadcast...         | limit              |
| Force VID.....              | Disable         | Unicast.....                 | limit              |
| VLAN Port Mode.....         | 802.1Q Disable  | Multicast.....               | limit              |
| Egress Tag.....             | Unmodified      | Broadcast.....               | limit              |
| <del>Ingress Tag.....</del> | <del>None</del> | MGMT Frames.....             | limit              |
| Egress Rate .....           | 30M             | ARP.....                     | limit              |
|                             |                 | Bucket Increment....         | ae.                |
|                             |                 | CBS Limit.....               | 060000.            |
|                             |                 | EBS Limit.....               | ffffff0.           |

Press 'r': refresh, 'l': load default, 's': save, 'Esc': exit

This page left blank intentionally.

## Chapter 3. Panels

This chapter will provide the details of the front and rear panels of the SDH01A main system along with the panels of each tributary module.

### 3.1 Front View



Figure 3-1 SDH01A front View

#### 3.1.1 Tributary status LEDs

| Slot | 1 | 2 | 3 | 4 |
|------|---|---|---|---|
| CH1  |   |   |   |   |
| CH2  |   |   |   |   |
| CH3  |   |   |   |   |
| CH4  |   |   |   |   |

Figure 3-2 Tributary status LED

##### ■ QE1 card

From 1 to 4: slot 1 to slot 4, CH1 to CH4: Channel 1 to Channel 4, status indicators for E1 channels. Four kinds of status, Green, Red, Flashing Red, and Off for these LED:

- Green: normal status.
- Red: LOS alarm.
- Flashing Red: AIS alarms.
- Flashing Green: RDI alarms.
- Off: in OOS (Out Of Service) mode.

##### ■ QSW card

From 1 to 4: slot 1 to slot 4, CH1 to CH4: Channel 1 to Channel 4, status indicators for Ethernet channels. Three kinds of status, Green, Red, and Off for these LED:

- Green: Link Up on corresponding Ethernet port.
- Red: Link Down on corresponding Ethernet port.
- Off: in OOS (Out Of Service) mode.

### ■ QV35 card

From 1 to 4: slot 1 to slot 4, CH1 to CH4: Channel 1 to Channel 4, status indicators for V35 channels. Three kinds of status, Green, Red, and Off for these LED:

- Green: normal status.
- Red: LOS alarm.
- Off: in OOS (Out Of Service) mode.

### ■ 8xE1 card

From 1 to 4: slot 1 to slot 4, CH1 to CH4: Channel 1/5 to Channel 4/8, status indicators for E1 channels. Four kinds of status, Green, Red, Flashing Red, and Off for these LED:

- Green: normal status.
- Red: LOS alarm.
- Flashing Red: AIS alarms.
- Flashing Green: RDI alarms.
- Off: in OOS (Out Of Service) mode.

## 3.1.2 Alarm Indication LEDs

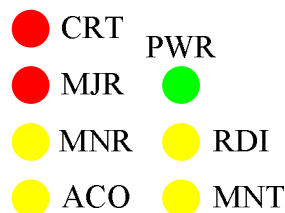

Figure 3-3 Alarm indication LED

- CRT LED: critical alarm indicator
  - Red : critical alarm is occurring in local system
  - Off : no critical alarm in local system
- MJR LED: major alarm indicator
  - Red : major alarm is occurring in local system
  - Off : no major alarm in local system
- MNR LED: minor alarm indicator
  - Yellow : minor alarm is occurring in local system
  - Off : no minor alarm in local system
- ACO LED : ACO status indicator
  - Yellow: the alarm cut off is enabled
  - Off: the alarm cut off is disabled
- PWR LED: System power indicator
  - Green: system power is normal
  - Off: system power loss
- RDI LED: Remote defect/alarm indicator
  - Yellow: remote system has alarm status
  - Off: remote system status is normal
- MNT LED: maintenance status indicator
  - Yellow: local system is under maintenance status (loop back or self diagnostic)
  - Off: local system is not under maintenance status

### 3.1.3 RJ-45 Ethernet Connector NMS

This is the NMS network management system interface for SNMP management by 10/100M Ethernet. The selection of 10 or 100M data rate is auto negotiable. LAN interface uses standard RJ-45 female connector. The pin assignment follows MDI standard as below.

| Pin Number | Function |
|------------|----------|
| 1          | Tx+      |
| 2          | Tx-      |
| 3          | Rx+      |
| 4          | NC       |
| 5          | NC       |
| 6          | Rx-      |
| 7          | NC       |
| 8          | NC       |

Table 3-1 RJ-45 pin assignments

### 3.1.4 Console Interface

Console interface provides a menu-driven user interface to manage the equipment. The connection is a 9 pin D-sub female connector. Please refer to Chapter 6 System Operation and Appendix B Menu-Driven Operations for details. The pin assignment for the DB9 is below. Only three wires are needed.

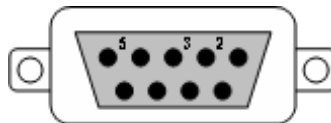

Figure 3-4 Console Pin Allocation (DB9)

| Pin Number | Function |
|------------|----------|
| 1          | NC       |
| 2          | Tx       |
| 3          | Rx       |
| 4          | NC       |
| 5          | GND      |
| 6          | NC       |
| 7          | NC       |
| 8          | NC       |

Table 3-2 CONSOLE pin assignment (DB9)

### 3.1.5 Optical interface LED Indication

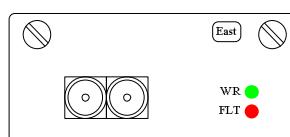

Figure 3-5 Optical interface LED Indicators

SDH01A provides 2 optical interfaces when install with optional 1+1 protection.

Please use the following table for an explanation of LED indications. If EAST is the working path, and WEST is the protection path, then the system will switch from EAST to WEST if it detects malfunction of EAST fiber link.

| EAST/ WEST |          | Indication  |
|------------|----------|---|
| WK         | FLT(red) | ● : green   ◆ : orange   ★ : light   ☆ : off   ☼ : flashing |
| ☆          | ☆        | This path is out-of-service.                                |
| ●          | ☆        | This path is working path; everything is fine.              |
| ●          | ★        | This path is working path; critical defect is detected.     |
| ●          | ☼        | This path is working path; remote defect is detected.       |
| ◆          | ☆        | This path is protection path; everything is fine.           |
| ◆          | ★        | This path is protection path; critical defect is detected.  |
| ◆          | ☼        | This path is protection path; remote defect is detected.    |

### 3.1.6 RESET Push Button

Push this button to reset and restart the system without turning off and turning on system power.

### 3.1.7 ACO Push Button

ACO (Alarm Cut Off) is used to turn off the audible contact for the office alarm and stop any sound caused by the alarm. The system will activate the relay contact closures of the office alarm when there are alarms detected by system. This can also inform the people on duty in the office by enabling the visible LED on the alarm panel. The manager can push the ACO button to deactivate the alarm. The ACO LED will light on at the same time to indicate this cut off action and remain on until the disappearance of alarm. If a new alarm occurs again before the existing alarm recovers, the ACO LED will turn off.

### 3.1.7 LCD Panel and Keypads

The user can manage the equipment by using the LCD panel and 4 keypads. Please refer to Appendix C LCD Operations for details.

### 3.1.8 Alarm output Interface

The alarm relay outputs are provided by the DB9 connector and are defined as follows in the table.

| Pin Number | Alarm Out     |
|------------|---------------|
| 1          | Alarm _Out0_A |
| 2          | Alarm _Out1_A |
| 3          | Alarm _Out2_A |
| 4          | Alarm _Out3_A |
| 5          | NC            |
| 6          | Alarm _Out0_B |
| 7          | Alarm _Out1_B |
| 8          | Alarm _Out2_B |
| 9          | Alarm _Out3_B |

Table 3-3 Alarm pin assignment (DB9)

### 3.2 Rear View



Figure 3-6 SDH01A rear view

#### 3.2.1 Power Connection

See Figure 3-7 for AC module and 3-8 for DC module.

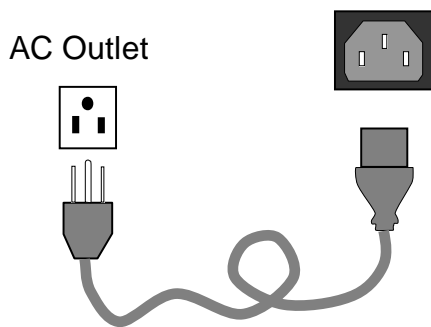

Figure 3-7 AC Module Connection

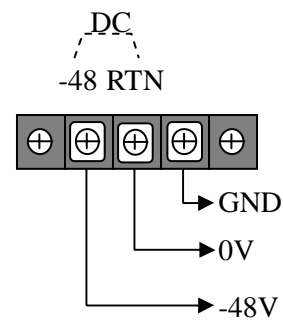

Figure 3-8 DC Modules Connection

- AC 90~264VAC, 44~63Hz
- Connector Type – IEC standard C14 AC Socket
- DC -36~-72V
- Connector Type – Terminal Block with Screws
- Use both AC and DC for power redundancy
- Max Power provided by power module : 40 Watts

#### 3.2.2 Frame Ground

The "GND" terminal is provided to connect the Frame Ground when using DC and also for case protection. It is located on the DC terminal block and is marked as "GND". If you use AC, the frame ground is derived from the "third" pin of the AC jack.

#### 3.2.3 Electrical Power Switch

On/off switch is used to turn on/off both AC/DC powers.



Figure 3-9 Electrical power switch

### 3.2.4 Tributaries Slots from 1 to 4

The SDH01A provides 4 low speed tributary slots on the rear panel for various interfaces and services according to user's requirements.

## 3.3 Tributary cards

### 3.3.1 E1 interface

#### **QE1B:**

- Channels from 1 to 4
- Connector type: BNC
- Impedance:  $75\Omega\pm 5\%$
- Each channel includes Tx and Rx, besides there is a ground signal

#### **8E1B:**

- Channels from 1 to 8
- Connector type: RJ-45
- Impedance:  $75\Omega\pm 5\%$

#### **8E1R:**

- Channels from 1 to 8
- Connector type: RJ-45
- Impedance:  $120\Omega\pm 5\%$

### 3.3.2 Ethernet interface card

#### **QSW:**

- Channels from 1 to 4
- Connector type: RJ-45
- 10/100 Mbps with auto negotiation
- Each channel has Ethernet status LED indicators

### 3.3.3 V35 interface card

#### **QV35:**

- Channels from 1 to 4
- Connector type: DB-44 (DB-44 to M34 converter)
- Data rate:  $N \times 64\text{Kbps}$  ( $N=1$  to 32)

## Chapter 4. Installation

This chapter will describe the procedures to install the equipment and other information that you need to know.

### 4.1 Install Equipment and Start the System

1. Mount the equipment in rack or place on table or shelf
2. Make sure the power switch is off
3. "GND" is provided to connect the Frame Ground and it is also required for lightening protection. It is located on the DC terminal block and marked as "GND". Before installation, please make sure you connect the GND terminal to frame ground.

#### 4.1.1 Install AC Power

1. Mount the equipment in rack or place on table or shelf
2. Turn the power switch off
3. Connect AC power cord to AC power supply
4. Turn on the switch

#### 4.1.2 Install DC Power

1. Set and check the power output of DC power supply for the proper range
2. Turn off the power supply before connecting power cable. Connect power cables. Please check the polarity of positive and negative carefully.
3. Connect GND terminal to frame ground
4. Turn on the power supply
5. Double check the power and polarity. Then turn on the power switch of the equipment.

#### 4.1.3 Start the System

After the electrical power is applied, the system will start to initialize and set up. The LED indicators on the panel will flash while the unit initializes and stop flashing after the configuration upload is done. The configuration conditions in default mode have all transmissions in IS mode (in-service) when the unit leaves the factory.

### 4.2 Installation of Tributary Cards

The SDH01A utilizes a module design which allows users to insert modules one by one according to their specific needs. Users can also equip different service modules by application, such as E1 interface and/or data services like V.35 or Ethernet. Each channel can be configured or set independently.

### 4.3 Management Interface

#### 4.3.1 Console Interface

The user can connect via the console port to any VT-100 compatible terminal or PC/Laptop with terminal emulation program and RS-232 cable. Please refer to chapter 3.1.4 for the RS-232 port pin definition and chapter 7.3 for parameters and settings.

#### 4.3.2 NMS Interface

The NMS port is an RJ-45 Ethernet port with pin defined as MDI. Please refer to Chapter 3.1.3. After connecting to management center through LAN/DCN or Internet and provisioning, the NMS can manage SDH01A centrally.

The cable for Ethernet should be UTP-5 or better and the length should not exceed 100 meters.

### 4.4 Connect Cables

#### 4.4.1 Connect Fiber Cable

The fiber cable/patch cord between SDH01A and the ODF should have the right type of connectors and be of suitable length. Please tighten the connector normally and do not bend the fiber cable itself, too avoid damaging the fiber while connecting. Be careful around laser light sources and never look directly into the end of a cable or into the connectors of fiber transceivers. This may cause permanent damage to your eyes.

#### 4.4.2 Connect E1 Cable

Short haul E1 connections are typically made with coaxial cable and connectors with BNC. On the QE1B module, the upper row of BNCs connectors are data output ports, while the lower row of connectors are data input ports. Make sure that the connection is correct. If E1 connection is RJ-45, a BALUN may be used to convert RJ-45 to BNC.

#### 4.4.3 QSW Interface

The user can connect the CAT-5 UTP Cable to the RJ-45 connector. Since the Quad Switch supports auto-MDIX, there is no need to choose between Ethernet straight or crossover cables, just connect normally.

#### 4.4.4 QV35 Interface

The user can connect DB-44 port to the DB-44 to 2xMB34 converter cables on the Quad V.35 card to connect to normal V.35 DTE interfaces.

### 4.5 Install Office Alarm

The office alarm relay ports as described in chapter 3.1.9. The SDH01A can connect alarms to the central alarm panel in office to inform the manager on duty by visible or audible indicators, when there is an alarm condition occurring. The office alarm relay limitations are described below.

Maximum voltage: 60V

Maximum current: 100mA (continuous) / 350mA (peak to peak)

### Chapter 5. Module Description

SDH01A is equipped with four module tributary slots to provide flexible applications and full services. The modules are described below.

#### 5.1 QE1B: 4 channel E1 module

Connector type: BNC

Impedance:  $75\Omega\pm 5\%$

This ITU-T G.703 E1 (2.048 Mbps) transmission module provides 4 channels to transmit transparently. The E1 interfaces meet ITU-T (G.703) and ANSI standards. Each of the E1 channels may be configured through the management interface. The parameter settings, such as line code (HDB3/AMI), are field selectable. These functions can be provisioned via system console or LCD. While any one E1 channel is being provisioned, the other channels should not be affected during the provisioning process. The E1 interfaces are individually terminated.

#### 5.2 8E1B: 8 channel E1 module

Connector type: RJ-45

Impedance:  $75\Omega\pm 5\%$

This E1 (2.048 Mbps) transmission module provides 8 channels to transmit transparently. The E1 interfaces meet ITU-T (G.703) and ANSI standards. Each of the E1 channels may be configured through the management interface. The parameter settings, such as line code (HDB3/AMI), are field selectable. These functions can be provisioned via system console or LCD. While any one E1 channel is being provisioned, the other channels should not be affected during the provisioning process. The E1 interfaces are individually terminated.

#### 5.3 8E1R: 8 channel E1 module

Connector type: RJ-45

Impedance:  $120\Omega\pm 5\%$

This E1 (2.048 Mbps) transmission module provides 8 channels to transmit transparently. The E1 interfaces meet ITU-T (G.703) and ANSI standards. Each of the E1 channels may be configured through the management interface. The parameter settings, such as line code (HDB3/AMI), are field selectable. These functions can be provisioned via system console or LCD. While any one E1 channel is being provisioned, the other channels should not be affected during the provisioning process. The E1 interfaces are individually terminated.

#### 5.4 QSW: 4 Port 10/100M Ethernet Module

The QSW (Quad Switch) module provides up to 4 channels of 10/100M Ethernet transmission. The user can assign the Ethernet bandwidth in the high-speed optical signal for data communications between two ends by VC-12 assignment. The basic incremental unit of the bandwidth is one standard VC-12 (about 2.176 Mbps).

#### 5.5 QV35: 4 channel V.35 Module

The QV35 (Quad V.35) module provides up to 4 channels of  $N \times 64$ Kbps (where  $N=1$  to 32) transmission. The V.35 interfaces meet the ITU-T V.35 standard. The user can assign the bandwidth and clock source through the management interface. DTR/RDL/LLB signals can be ignored since some V.35 DTE do not provide these signals currently.

## Chapter 5. Module Description

QV35 Card, HDB44 to 2 x MB34 (Winchester) adapter cable pin assignment.

| HDB44   | V.35 CH 1 |         | V.35 CH 2 |         |
|---------|-----------|---------|-----------|---------|
| Pin No. | PIN No.   | Signal  | PIN No.   | Signal  |
| 1       |           |         |           |         |
| 2       |           |         | V         | RxCLK   |
| 3       |           |         | X         | RxCLK+  |
| 4       |           |         | D         | CTS     |
| 5       |           |         | C         | RTS     |
| 6       |           |         | NN        | undef   |
| 7       |           |         | N         | undef   |
| 8       | B         | SigGND  |           |         |
| 9       | L         | undef   |           |         |
| 10      | E         | DSR     |           |         |
| 11      | C         | RTS     |           |         |
| 12      | D         | CTS     |           |         |
| 13      | X         | RxCLK+  |           |         |
| 14      | V         | RxCLK   |           |         |
| 15      |           |         |           |         |
| 16      |           |         | A         | Shield  |
| 17      |           |         | P         | TxD     |
| 18      |           |         | S         | TxD+    |
| 19      |           |         | U         | ExtCLK  |
| 20      |           |         | W         | ExtCLK+ |
| 21      |           |         | E         | DSR     |
| 22      |           |         | L         | undef   |
| 23      | N         | undef   |           |         |
| 24      |           |         |           |         |
| 25      | H         | DTR     |           |         |
| 26      | W         | ExtCLK+ |           |         |
| 27      | U         | ExtCLK  |           |         |
| 28      | S         | TxD+    |           |         |
| 29      | P         | TxD     |           |         |
| 30      | A         | Shield  |           |         |
| 31      |           |         |           |         |
| 32      |           |         | Y         | TxCLK   |
| 33      |           |         | AA        | TxCLK+  |
| 34      |           |         | R         | RxD     |
| 35      |           |         | T         | RxD+    |
| 36      |           |         | F         | DCD     |
| 37      |           |         | H         | DTR     |
| 38      |           |         | B         | SigGND  |
| 39      | F         | DCD     |           |         |
| 40      | T         | RxD+    |           |         |
| 41      | R         | RxD     |           |         |
| 42      | AA        | TxCLK+  |           |         |
| 43      | Y         | TxCLK   |           |         |
| 44      |           |         |           |         |

Table 5-1 QV35 Pin assignment

### Chapter 6. System Operations

#### 6.1 Start and Reset System

##### 6.1.1 Power Supply

The SDH01A can be supplied by 110/220 AC or -48V DC power. The system will work with only one of the powers applied. When both are applied, the AC will work alone. The system will use the power from AC normally, and then switch to DC power when there is a fault with AC power. There will be no interruption to the system during the power switch. The user can turn on or turn off both the AC and DC powers by the switch on the rear. After power is applied normally, the SDH01A starts the POST (Power-On Self Test) and then initializes the system with the data in the non-volatile backup memory. After POST has passed, the system will work normally. The SDH01A can report the power loss alarm (PLS: Power Loss) of remote site to the management system when the power of remote equipment fails. AC power after completion of lightning surge immunity test, a temporary degradation of transmission performance or temporary loss of function might be acceptable, but the equipment and protection device must be self-recoverable and pass operationally within 10 minutes. To fulfill surge protection in easy-installation manner, the SDH01A is incorporated with chassis grounding mechanism on the exterior of device.

##### 6.1.2 System Reset

The user can reset the SDH01A in different ways according to different conditions.

**Push button reset:** This will restart the microprocessor and clear the PM and alarm records. There is no change to system settings and no interruption in the working traffic.

**Software reset by management systems:** This will restart the microprocessor and clear the PM and alarm records. There is no change to system settings and no interruption in the working traffic.

**Hardware reset by management systems:** This will restart the microprocessor and clear the PM and alarm records. There is no change to system settings. However, traffic will be interrupted until the hardware recovers.

**Reset back to previous version by management systems:** After command executed, the software settings will revert back to the previous version in case that current settings are damaged.

##### 6.1.3 System Provisioning

For convenience, the SDH01A is set to normal working state and the transmissions are enabled on the first system start. All the settings and parameters follow default values. The user can then set and provision the system according to the practical applications by NMS, console or LCD interfaces, including aggregate interfaces, tributary interfaces, and the main system.

All the settings will be kept in non-volatile backup memory after provisioning and used to initialize and set up the system when the user restarts the system again. The system can also be reset back to factory default conditions by command. SDH01A provides summary reports for the user to understand the status and conditions of the system, including service status, service type, frame format, line code, loopback, and alarm type. The default settings and values are listed on the next page.

## Chapter 6. Maintenance and Self-Diagnostic Testing

|                  |                      |
|------------------|----------------------|
| Alarm Category   | Default Severity     |
| UEQ/EQU          | Event                |
| LOS              | Critical             |
| LOF              | Major                |
| AIS              | Minor                |
| RDI              | Minor                |
| Parameter        | Default Setting      |
| Protection Mode  | Non-revertive        |
| WTR Time         | 0 min                |
| Switch Threshold | 3 x 10 <sup>-5</sup> |
| ALS Mode         | Disable              |
| Delay Time       | 300sec               |
| Mode             | E1                   |
| Impedance        | 75ohm                |
| Line Code        | HDB3/AMI             |
| PM Category      | Threshold            |

| Threshold Value | Optical Line |      |        | Optical Path |      |        |
|-----------------|--------------|------|--------|--------------|------|--------|
|                 | 15-min       | 1-hr | 1-day  | 15-min       | 1-hr | 1-day  |
| CV              | 1400         | 5600 | 134400 | 1353         | 5412 | 129890 |
| ES              | 180          | 720  | 17280  | 180          | 720  | 17280  |
| SES             | 45           | 180  | 4320   | 45           | 180  | 4320   |
| UAS             | 18           | 72   | 1728   | 18           | 72   | 1728   |
| Threshold Value | E1 Line      |      |        | E1 Path      |      |        |
|                 | 15-min       | 1-hr | 1-day  | 15-min       | 1-hr | 1-day  |
| CV              | 369          | 1475 | 35400  | 415          | 1659 | 39813  |
| ES              | 180          | 720  | 17280  | 180          | 720  | 17280  |
| SES             | 45           | 180  | 4320   | 45           | 180  | 4320   |
| UAS             | 18           | 72   | 1728   | 18           | 72   | 1728   |

Table 6-1 System default settings and values

## 6.2 Performance Management

SDH01A provides performance-monitoring functions for optical and electrical interfaces to monitor the transmission quality. This monitoring includes line and path for both local and remote sites. Table 6-2 lists the details. (CV=Code Violation, ES= Errored Seconds, SES=Severely Errored Seconds, UAS=UnAvailable Seconds)

|              | Near-End         | Far-End          |
|--------------|------------------|------------------|
| Optical Line | CV, ES, SES, UAS | CV, ES, SES, UAS |
| Optical Path | CV, ES, SES, UAS | CV, ES, SES, UAS |
| E1 Line      | CV, ES, SES, UAS | CV, ES, SES, UAS |
| E1 Path      | CV, ES, SES, UAS | CV, ES, SES, UAS |

Table 6-2 PM parameters

The PM time intervals are 15-minutes, one-hour and one-day. In addition to current 15-minute and one-day intervals, the previous 96 15-minute (24 hours) one-hour (24 hours) and 7 one-day (one week) intervals will be recorded in system memory for user to retrieve by NMS, CONSOLE or LCD. The SDH01A also provides the user with the threshold for each PM. The user can set the threshold value for each 15-minute, one-hour and one-day PM parameter. The system will report TCA (Threshold Crossing Alarm) alarm to management interfaces when the PM value monitored exceeds the threshold.

## 6.3 Optical Interface Operation

The SDH01A provides 1+1 auto protection switching for optical line protection with Optical modules in the system. The aggregate receiving signal will come from the working fiber line, and the other line will be standby for protection purposes. When the working line detects LOS, LOF, or AIS, the system will switch the fiber line from the working to the standby fiber. The switching time is less than 30ms. The optical protection mechanism is well designed to prevent any instability between working and protection optical lines.

There are two kinds of APS function: Revertive and Non-revertive. Under non-revertive mode, the optical line will not switch back to the original one even if it recovers to normal working state. When the setting is under revertive mode, the system will define the primary slot/module to be working line. After APS implementation, the optical line will switch to protection line. If the working line is recovered, the fiber line will switch back to the primary/working line again.

The protection switch can be implemented by the management system. The user can operate the command manually through NMS, CONSOLE, or LCD. There are two ways for the manual switch: Normal and Lock. In normal mode, the switch will be implemented only if the protection line is in normal status. But in the lock mode, the user can make the switch no matter if the protection line is good or bad. The SDH01A will generate AIS signal on all E1 channel outputs during optical line failure.

The SDH01A provides ALS (Auto Laser Shutdown) function. The laser transmitter on local site will shut down the power output when it cannot receive remote site optical laser signal properly. The laser output will be turned on periodically to send out signal for testing whether the remote site can receive normally. The laser will work normally again after remote site recovers receiving. The user can also test and start laser manually. The parameters of optical module are in the next table.

| Parameter       | Settings                |
|-----------------|-------------------------|
| WTR Time        | 0~15min                 |
| ALS Mode        | Enable/Disable          |
| Delay Time      | 60~300sec               |
| Protection Mode | Revertive/Non-revertive |

Table 6-3 Optical module parameters

**\*Warning\*** DO NOT stare at the output of laser or fiber connector when the equipment is in a powered on state. The laser beam may cause damage to your eyes.

### 6.4 Cross Connect and Mapping Table

The SDH01A maps its channel resources from tributary interfaces to STM-1 using the ITU-T numbering system. For example, if you assign slot 2 port 1 to channel 5 in SDH01A system, the traffic from slot 2 port 1 will be added into the channel (K, L, M) = (2, 2, 1) in STM-1 pool. The data stream from the channel (K, L, M) = (2, 2, 1) in STM-1 pool will be dropped and inserted into slot 2 port 1.

The table below shows the ITU-T numbering system and their respective (K, L, M) number.

| ITU-T | TUG3(K) | TUG2(L) | TU12(M) | ITU-T | TUG3(K) | TUG2(L) | TU12(M) |
|-------|---------|---------|---------|-------|---------|---------|---------|
| 1     | 1       | 1       | 1       | 33    | 3       | 4       | 2       |
| 2     | 2       | 1       | 1       | 34    | 1       | 5       | 2       |
| 3     | 3       | 1       | 1       | 35    | 2       | 5       | 2       |
| 4     | 1       | 2       | 1       | 36    | 3       | 5       | 2       |
| 5     | 2       | 2       | 1       | 37    | 1       | 6       | 2       |
| 6     | 3       | 2       | 1       | 38    | 2       | 6       | 2       |
| 7     | 1       | 3       | 1       | 39    | 3       | 6       | 2       |
| 8     | 2       | 3       | 1       | 40    | 1       | 7       | 2       |
| 9     | 3       | 3       | 1       | 41    | 2       | 7       | 2       |
| 10    | 1       | 4       | 1       | 42    | 3       | 7       | 2       |
| 11    | 2       | 4       | 1       | 43    | 1       | 1       | 3       |
| 12    | 3       | 4       | 1       | 44    | 2       | 1       | 3       |
| 13    | 1       | 5       | 1       | 45    | 3       | 1       | 3       |
| 14    | 2       | 5       | 1       | 46    | 1       | 2       | 3       |
| 15    | 3       | 5       | 1       | 47    | 2       | 2       | 3       |
| 16    | 1       | 6       | 1       | 48    | 3       | 2       | 3       |
| 17    | 2       | 6       | 1       | 49    | 1       | 3       | 3       |
| 18    | 3       | 6       | 1       | 50    | 2       | 3       | 3       |
| 19    | 1       | 7       | 1       | 51    | 3       | 3       | 3       |
| 20    | 2       | 7       | 1       | 52    | 1       | 4       | 3       |
| 21    | 3       | 7       | 1       | 53    | 2       | 4       | 3       |
| 22    | 1       | 1       | 2       | 54    | 3       | 4       | 3       |
| 23    | 2       | 1       | 2       | 55    | 1       | 5       | 3       |
| 24    | 3       | 1       | 2       | 56    | 2       | 5       | 3       |
| 25    | 1       | 2       | 2       | 57    | 3       | 5       | 3       |
| 26    | 2       | 2       | 2       | 58    | 1       | 6       | 3       |
| 27    | 3       | 2       | 2       | 59    | 2       | 6       | 3       |
| 28    | 1       | 3       | 2       | 60    | 3       | 6       | 3       |
| 29    | 2       | 3       | 2       | 61    | 1       | 7       | 3       |
| 30    | 3       | 3       | 2       | 62    | 2       | 7       | 3       |
| 31    | 1       | 4       | 2       | 63    | 3       | 7       | 3       |
| 32    | 2       | 4       | 2       |       |         |         |         |

Table 6-4 Cross Connect and (K, L, M) mapping table

### 6.5 Timing Synchronization

The SDH01A accepts two simultaneous reference input signals, the primary reference (REF0) and the secondary reference (REF1). However, only one is selected as the active reference input. Each reference has 2 options for selection:

1. West Side STM-1 Recovery
2. East Side STM-1 Recovery

REF0 can be selected as West Side STM-1 Recovery and REF1 selected as East Side STM-1 Recovery, then a hitless reference switch can be done from West optical side to East optical side when the active reference input is changed from REF0 to REF1.

There are three modes for the active reference input selection:

#### **Freerun mode:**

Freerun mode is typically used when an independent clock source is required, or immediately following system power-up before network synchronization is achieved. In Freerun mode, the SDH01A provides timing and synchronization signals which are based on the master clock frequency only, and are not synchronized to any reference input signals.

#### **Normal mode:**

Normal mode is typically used when a system clock source, synchronized to the network is required. In Normal mode, the SDH01A provides timing and frame synchronization signals, which are synchronized to one of the two reference inputs (REF0 or REF1). If the SDH01A determines that its active selected reference is disrupted, it will change to Holdover mode until the selected reference is no longer disrupted or another reference is selected that is not disrupted.

#### **Holdover mode:**

Holdover mode is typically used for short durations while network synchronization is temporarily disrupted. In Holdover mode, the SDH01A provides timing and synchronization signals, which are not locked to any reference input signal, but are based on storage techniques. The storage value is determined while the device is in Normal Mode and locked to a reference input signal.

### 6.6 Alarm Management

While the system is working, the microprocessor scans and monitors every interface and channel to determine whether there are any alarms or not. Once an alarm is detected, the system will report the alarms to the management system. The SDH01A can keep 99 alarm records internally for analysis per system level. The information with the alarm includes date and time of occurrence, the managed object and location, the type and name of alarm, alarm severity, and so on.

The user can also retrieve the current alarms and the history. This alarm detection can be enabled or disabled for each interface and channel according to user requirements. Table 6-2 lists the alarm type and default severity of SDH01A. (E1 LOF and RDI are for E1 interface.) The severity of alarm can be assigned as Event, Minor, Major, or Critical. The critical, major, or minor office alarm and LED will be activated when the corresponding alarm occurs. While LOS, LOF, and AIS alarms of optical or E1 interface are detected, the AIS signal will be sent out on the downstream direction or remote output.

| Alarm Category | Default Severity |
|----------------|------------------|
| UEQ/EQU        | Event            |
| LOS            | Critical         |
| LOF            | Major            |
| AIS            | Minor            |
| RDI            | Minor            |

Table 6-5 Alarm type

## 6.7 Alarm Event Log

Our system has an internal memory capable of holding different events for alarm logs; this will hold up to 9999 different alarm log events that can be stored for user reference.

## 6.8 E1 Interface Operation

E1 interfaces are low speed tributary services of the SDH01A. The user can build the network capacity step by step according to the demands. The average traced frequency deviation at the output port of E1 is less than  $\pm 1 \times 10^{-11}$  referenced to the frequency at the input port. (The measurement is after 30 minutes warm-up.) The interval of testing is 100s and the measurement data sampled is more than 180. The SDH01A and test equipment shall be connected as in Figure 6-1. The parameters of E1 are as follows.

| Parameter | Settings |
|-----------|----------|
| Mode      | E1       |
| Impedance | 75 ohm   |
| Line Code | HDB3/AMI |

Table 6-6 E1 module parameters

## 6.9 Time Interval Error (TIE)

The SDH01A is used in synchronous applications. Two SDH01As can trace and lock their time precisely. Please see the following for detailed verifications.

The test was performed at a temperature of 25°C and 30 minutes after the system has been up and running. 180 samples at every 100 seconds are recorded. The results verify that the TIE of the SDH01A is less than  $1 \times 10^{-11}$  ns.

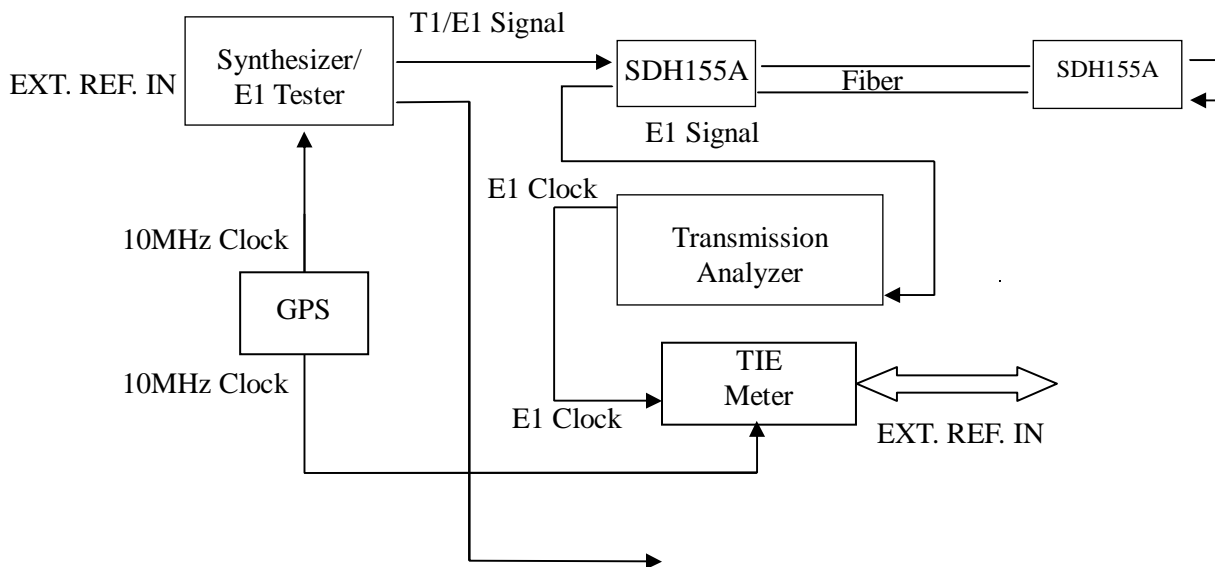

Figure 6-1 The frequency tractability connected

## 6.10 Ethernet Transmission

The bandwidth in the high-speed optical signal for each module or channel is adjustable and can be assigned by user according to the network applications. The size of this bandwidth is in steps of 2.048 Mbps. That is, the bandwidth is  $N \times 2.048$  Mbps, where  $N$  is from 1 to 63. Since all the Ethernet channels of QSW share this 100M, the sum of all the  $N$  values of Ethernet channels cannot be more than 63. The default value of  $N$  is 0. The user must be careful and assign the  $N$  value for each module/channel when the new QSW is inserted. The bandwidth for Ethernet transmission is independent of the E1.

### 6.11 Maintenance and Self-Diagnostic Testing

In order to help in solving transmission problems, the SDH01A provides loop back and self-diagnostic testing for maintenance people to debug and troubleshoot problems quickly.

#### 6.11.1 Loop back function

There are loop back functions at different locations on the transmission path of each high-speed aggregate and low speed tributary, including line loop back and diagnostic loop back. The user can operate the loop back at both local and remote equipments; the MNT LED will be turn on. During loop back, the system will transmit the received signal to both loop back directions and up or down stream. The definitions of loopback are shown below.

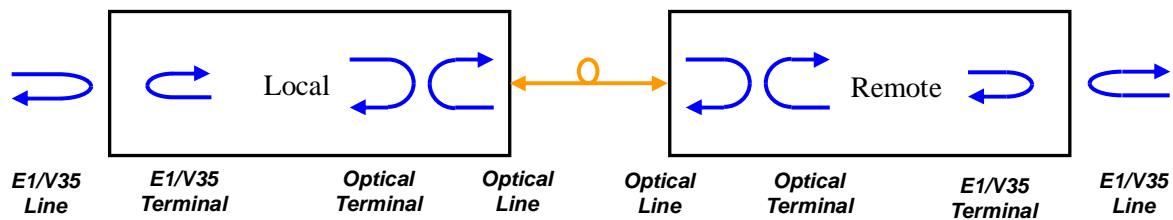

Figure 6-2 Loopback definitions

#### 6.11.2 Self Diagnostic Testing

The SDH01A has a built-in signal generator with a  $2^{15}-1$  test pattern and detector for bit errors. These can test and check the transmission quality by working with loopback at different locations. The user can operate and get the testing results through Console, NMS or LCD.

### 6.12 Administration Security

In order to prevent operations from unauthorized users, the SDH01A provides security for administration via user login. The user must log in the system first by valid user name and correct password before operating. The new user needs to apply for the account from the supervisor.

### 6.13 System Management

During management of the equipment, the user can retrieve the version and set the date and time of the system through the management interfaces. There is no Y2K problem in the SDH01A system. In addition, the manager can set the IP address of NMS, trap IP address of the alarm report, and the community Read and Read-only strings for SNMP to build the network management system.

This page left blank intentionally.

### Chapter 7. Network Management

The SDH01A provides LCD, Console and NMS interfaces for network management. For in the field support, the LCD is a convenient way to operate and debug. But it is limited by the small 16x2 row display. The Console can display many messages on the same page. This is good and quick for managers to manage after connecting a terminal or PC/Laptop with terminal program. The NMS is a standard management interface with Ethernet physical layer and SNMP protocol. All these three interfaces provide full functions of OAM&P. The management systems are single ended and the user can manage both local and remote systems from one unit through the DCC.

#### 7.1 NMS Interface and SNMP

The SDH01A supports SNMP v2c, and follows RFC1406, RFC 2495, RFC 2493 (PM) and self defined parameters for SNMP MIB. The protocol layers of SDH01A's NMS interfaces are Ethernet, IP, UDP, and SNMP. The user can manage the equipment by a window's based management software, which uses a GUI (Graphical User Interface), making it friendly and easy to use. The user can also use other SNMP management software to manage the remote nodes, or develop their own management and integrate with other systems by importing the SNMP MIB provided, to manage the remote nodes.

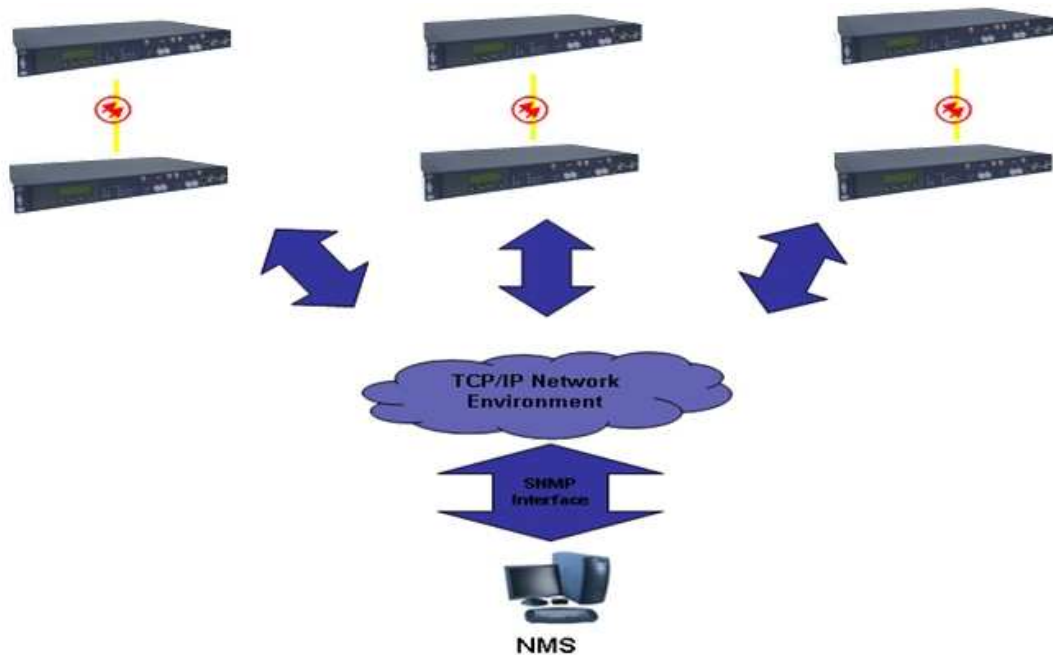

Figure 7-1 SNMP NMS structure

### 7.2 NMS Functions

The SDH01A provides full OAM&P (Operation, Administration, Maintenance, and Provisioning) functions. The management functions are as follows.

- Configuration
- Fault Management
- Performance Monitoring
- Security Management
- Operation
- System Setup

### 7.3 Console Interface

The SDH01A also reports the alarms to console port in addition to NMS. The user can manage local and remote SDH01A through the console interface. The console interface is operated by menu-driven interface. Please refer to Appendix B for details. The Console settings are as follows.

| Baud Rate    | Data Bits | Parity | Stop Bit |
|--------------|-----------|--------|----------|
| 115, 200 bps | 8         | None   | 1        |

### 7.4 LCD Interface

The LCD is a convenient method for maintenance in the field. It uses a hierarchy menu and keypads to select and execute the commands. Please refer to Appendix C for details on operation of the LCD interface.

## **Appendix A. Ordering Information**

In addition to the main chassis of the SDH01A, there are also modules for selection. Both aggregate and tributary modules provide many options. Please refer to details below to order.

### **I. System**

- SDH01A/chassis x 1set
- Low speed tributary modules
- 19"/23" brackets and screws x 1set
- AC power cord x 1 pc.

### **II. Tributary Card**

Name/parameters..... Description

---

|                          |   |
|--------------------------|---|
| 1. QE1B (BNC).....       | 4 ch. E1 tributary card with BNC interface panel connectors   |
| 2. QSW.....              | Ethernet over SDH card, 4-channels 10/100, RJ-45              |
| 3. QV35.....             | 4 ch. V.35 tributary with DB-44 interface panel connectors    |
| 4. 8E1B(RJ-45) 75Ω.....  | 8 ch. E1 tributary card with BNC interface panel connectors   |
| 5. 8E1R(RJ-45) 120Ω..... | 8 ch. E1 tributary card with RJ-45 interface panel connectors |

### Appendix B. Menu-Driven Operations

The Console provides a pull down menu, the Menu-Driven Interface, using the serial port to manage the equipment. The keys used are ←→↑↓ [Enter] [Tab] [Esc]. The program for Menu-Driven interface is any terminal emulation program that supports VT-100. The data rate and settings are 115, 200bps, N, 8, 1, and no flow control.

#### [Operating Rules]

In main menu and sub menu, the item is selected by arrow keys, ←→↑↓, and then pressing [Enter] to enter the selected function. After entering the sub menu, the [Tab], ←→↑↓ keys are used to move to the parameter to edit. The item selected will be highlighted. You can use ←→ to change the value of the highlighted item and then press [Enter] or [Tab] to move to the next window or item. After "OK" is executed, the action is completed. You can exit or return to main menu anytime by pressing [Esc] before the "OK" is pressed.

The network topology of SDH01A is TM/ADM. There is a DCC channel between local and remote units to communicate messages. Through this channel, the Menu-Driven interface can manage the remote equipment as well. The default site to manage is local. You can change the site to remote by local/remote option on the main menu. After the remote site is selected, the operations are done to the remote equipment.

To provide Security, there is log in window to key in the user name and password before entering the menu-driven management. The default settings are user name, root; and password, root123.

```
+-----+
| [ SDH01A ] |
| F/W v1.3A 07/31/08 16:22 |
| Account: _ |
| Password:  |
|-----+
| < Login >   < Reset > |
+-----+
```

The first row in the screen shows brief information about menu driving, including login account name, model name, configuration target (local or remote) and current working path in menu driving. There are eight options in the main menu: "Alarm Management", "Performance Data", "Configuration", "Diagnosis Tools", "System Settings", "Account Management", "Node Access" and "Logout".

```
[root]>>SDH01A (LO) IP:192.168.0.161
1. Alarm Management
2. Performance Data
3. Configuration
4. Diagnosis Tools
5. System Settings
6. Account Management
7. Node Access
8. Logout
0. Previous Menu
```

## I. Alarm Management

Under Alarm Management there are "Alarm View", "Alarm Reset", and "Severity Setting" sub-functions.

1. Alarm View
2. Alarm Reset
3. Severity Setting
0. Previous Menu

### 1. Alarm View:

Select Alarm type (current or history) and Alarm Class as follows:

```

+-----+
| [ View Current/History Alarm ] |
|                                     |
| Alarm: Current                     |
|                                     |
| Class: ALL                         |
|                                     |
| < OK >                            < Cancel > |
+-----+
    
```

After [Enter] is pressed, the results window will display as follows:

Example (Class: All)

```

+-----+
| << View Current Alarm : ALL (1-16/23) >> |
+-----+
| Class  Type  Item  Port  Alarm      Severity  Date           |
+-----+-----+-----+-----+-----+-----+-----+
| OPT    Line  West  1     LOS        Critical  08/22/2008 11:25:07 |
| OPT    Line  East  1     LOS        Critical  08/22/2008 11:25:07 |
| OPT    Intf  East  --    READY      Event    08/22/2008 11:25:05 |
| OPT    Intf  West  --    READY      Event    08/22/2008 11:25:05 |
| QSW    Line  S-4   1     LINK_DOWN  Critical  08/22/2008 11:25:04 |
| QSW    Line  S-4   2     LINK_DOWN  Critical  08/22/2008 11:25:04 |
| QSW    Line  S-4   3     LINK_DOWN  Critical  08/22/2008 11:25:04 |
| QSW    Line  S-4   4     LINK_DOWN  Critical  08/22/2008 11:25:04 |
| QE1B   Line  S-3   1     LOS        Critical  08/22/2008 11:25:03 |
| QE1B   Line  S-3   2     LOS        Critical  08/22/2008 11:25:03 |
| QE1B   Line  S-3   3     LOS        Critical  08/22/2008 11:25:03 |
| QE1B   Line  S-3   4     LOS        Critical  08/22/2008 11:25:03 |
| QV35   Line  S-2   1     LOS        Critical  08/22/2008 11:25:03 |
| QV35   Line  S-2   2     LOS        Critical  08/22/2008 11:25:03 |
| QV35   Line  S-2   3     LOS        Critical  08/22/2008 11:25:03 |
| QV35   Line  S-2   4     LOS        Critical  08/22/2008 11:25:03 |
+-----+-----+-----+-----+-----+-----+-----+
    
```

Press 'r': refresh, 'R': auto-refresh, Arrows: other page, 'ESC': exit

Please use ←→ to scroll the window for more records.

The alarm types include:

- ARRIVAL: module detected
- MISSING: module removed
- LOS: Loss of Signal
- LOF: Loss of Frame (optional);
- AIS: Alarm Indication Signal
- RDI: Remote Defect Indicator (optional for E1)

## Appendix B. Menu-Driven Operations

### 2. Alarm Reset:

This function is used to reset the current or history alarms. Once the user chooses <Ok>, the current or history log of alarms will be deleted.

```
[ Reset Current/History Alarm ]
Alarm: Current
< OK >      < Cancel >
```

### 3. Severity Setting:

This function is used to retrieve and set the severity of alarm. Enter through "Alarm Management" -> "Severity Setting".

```
[ Alarm Severity ]
Optical LOS: Critical
        LOF: Major
        AIS: Minor
        RDI: Minor
E-X/DS-X LOS: Critical
        LOF: None
        AIS: None
        RDI: Minor
V. 35   LOS: Critical
        AIS: Minor
        RDI: Minor
ETH LINKDOWN: Critical
< Save >      < Abort >
```

Use ←→ to change the levels: Event, Minor, Major, or Critical. After "Save" is executed, the system will respond with success or not.



## Appendix B. Menu-Driven Operations

### 3.RMON Counters:

Statistic counters may be used in performance monitoring or to check problems in the network.

| Counter      | Port 1 | Port 2 | Port 3 | Port 4 | WAN |
|--------------|--------|--------|--------|--------|-----|
| InGoodBytes  | 0      | 0      | 0      | 0      | 0   |
| InBadBytes   | 0      | 0      | 0      | 0      | 0   |
| InUnicast    | 0      | 0      | 0      | 0      | 0   |
| InBroadcast  | 0      | 0      | 0      | 0      | 0   |
| InMulticast  | 0      | 0      | 0      | 0      | 0   |
| InPause      | 0      | 0      | 0      | 0      | 0   |
| InUndersize  | 0      | 0      | 0      | 0      | 0   |
| InFragment   | 0      | 0      | 0      | 0      | 0   |
| InOversize   | 0      | 0      | 0      | 0      | 0   |
| InJabber     | 0      | 0      | 0      | 0      | 0   |
| InRxErr      | 0      | 0      | 0      | 0      | 0   |
| InFCSErr     | 0      | 0      | 0      | 0      | 0   |
| OutBytes     | 0      | 0      | 0      | 0      | 0   |
| OutUnicast   | 0      | 0      | 0      | 0      | 0   |
| OutBroadcast | 0      | 0      | 0      | 0      | 0   |
| OutMulticast | 0      | 0      | 0      | 0      | 0   |

Press 'r': refresh, '<' or '>': select item, ' ': other page, 'ESC': exit

The counters are designed to support:

- RFC 2819 – RMON MIB (this RFC obsoletes 1757 which obsoletes 1271)
- RFC 2665 – Ethernet-like MIB (this RFC obsoletes 1643, 1623 and 1398)
- RFC 2233 – MIB II (this RFC obsoletes 1573 & 1213 with obsoletes 1229 & 1158)
- RFC 1493 – Bridge MIB (this RFC obsoletes 1286)

In this window the user can use ←→ to select slot and use SPACE to view page(s). Pressing Number 1-5 can reset counters for ports 1 to WAN, while pressing Number 0 will reset all counters.

#### Ingress Statistics Counters

**InGoodByte:** The sum of lengths of all good Ethernet frames received, that is frames that are not bad frames.

**InBadBytes:** The sum of lengths of all bad Ethernet frames received not counting Preamble.

**InUnicast:** The number of good frames received that have a Unicast destination MAC address.

**InBrdcast:** The number of good frames received that have a Broadcast destination MAC address.

**InMultcasts:** The number of good frames received that have a Multicast destination MAC address.

**InPause:** The number of good Flow Control frames received.

**InUnder:** Total frames received with a length of less than 64 octets but with a valid FCS.

**InFragment:** Total frames received with a length of less than 64 octets and an invalid FCS.

**InOversize:** Total frames received with a length of more than MaxSize octets but with a valid FCS.

**InJabber:** Total frames received with a length of more than MaxSize octets but with an invalid FCS.

**InRcvErr:** Total frames received with an Rx\_Error event seen by the receive side of the MAC.

**InFCSErr:** Total frames received with a CRC error not counted in InFragments, InJabber.

### *Egress Statistics Counters*

**OutBytes:** The sum of lengths of all Ethernet frames sent from this MAC. This includes Flow Control frames and partial frames transmitted due to collisions.

**OutUnicast:** The number of frames sent that have a Unicast destination MAC address. This does not include frames dropped due to excessive collisions or frames counted in OutFCSErr.

**OutBrdcast:** The number of good frames sent that have a Broadcast destination MAC address. This does not include 802.3 Flow Control frames, or frames dropped due to excessive collisions or frames counted in OutFCSErr.

**OutMltcast:** The number of good frames sent that had a Multicast destination MAC address. This does not include 802.3 Flow Control messages, nor frames counted in OutPause nor does it include Broadcast frames counted in OutBroadcasts.

**OutPause:** The number of Flow Control frames sent.

**Collisions:** The number of collision events seen by the MAC not including those counted in Late or Excessive.

**Deferred:** The total number of successfully transmitted frames that were delayed because the medium was busy during the first attempt and then the frame was transmitted without any collisions (this counter is valid in half-duplex mode only).

**Single:** The total number of successfully transmitted frames that experienced exactly one collision. This counter is applicable in half-duplex only.

**Multiple:** The total number of successfully transmitted frames that experienced more than one collision. This counter is applicable in half-duplex only.

**OutFCSErr:** The number of frames transmitted incorrectly due to an internal MAC transmits error, for example, bad CRC detected when the frame was read from memory.

**Excessive:** The number frames dropped in the transmit MAC due to excessive collision condition. This counter is applicable in half-duplex only.

**Late:** The number of late collision events seen by the MAC.

### *Histogram Counters*

**64Bytes:** Total frames received and transmitted with a length of exactly 64 octets, including those with errors.

**65 to 127:** Total frames received and transmitted with a length of between 65 and 127 octets inclusive, including those with errors.

**128 to 255:** Total frames received and transmitted with a length of between 128 and 255 octets inclusive, including those with errors.

**256 to 511:** Total frames received and transmitted with a length of between 256 and 511 octets inclusive, including those with errors.

**512 to 1023:** Total frames received and transmitted with a length of between 512 and 1023 octets inclusive, including those with errors.

**1024 to Max:** Total frames received and transmitted with a length of between 1024 and MaxSize octets inclusive, including those with errors.

## III. Configuration:

Under Configuration there are "Interface Summary", "General Settings", "Optical Interface", "E1 Interface", "V35 Interface", "Ethernet Interface", "Advanced ETH Setup", "Cross Connect Tab" and "Default Settings" sub menus.

1. Interface Summary
2. General Settings
3. Optical Interface
4. E-X/DS-X Interface
5. V.35 Interface
6. Ethernet Interface
7. Advanced ETH Setup
8. Cross Connect Tab
9. Default Settings
0. Previous Menu

### 1. Interface Summary:

Retrieve the summary report. Use ←→ to select the Item.

For optical interface, you will get:

| Item: <b>West</b> Class: <b>OPT</b> |         |     |         |          |          |        |       |
|-------------------------------------|---------|-----|---------|----------|----------|--------|-------|
| Port                                | Service | ALS | Restart | Loopback | Priority | Status | Alarm |
| 1                                   | IS      | no  | 300(s)  | None     | Primary  | Active | LOS   |

Press 'r': refresh, '<' or '>': select item, 'ESC': exit

For E1 interface, you will get:

| Item: <b>S-3</b> Class: <b>QE1B</b> |         |      |      |         |           |          |          |       |  |
|-------------------------------------|---------|------|------|---------|-----------|----------|----------|-------|--|
| Port                                | Service | Mode | Code | Frame   | Impedance | L-Len    | Loopback | Alarm |  |
| 1                                   | IS      | E1   | HDB3 | Unframe | 75 ohm    | ----- ft | None     | LOS   |  |
| 2                                   | IS      | E1   | HDB3 | Unframe | 75 ohm    | ----- ft | None     | LOS   |  |
| 3                                   | IS      | E1   | HDB3 | Unframe | 75 ohm    | ----- ft | None     | LOS   |  |
| 4                                   | IS      | E1   | HDB3 | Unframe | 75 ohm    | ----- ft | None     | LOS   |  |

Press 'r': refresh, '<' or '>': select item, 'ESC': exit

## Appendix B. Menu-Driven Operations

For V.35 interface, you will get:

| Item: S-2 |         | Class: QV35 |      |         |       |       |     |     |          |       |  |
|-----------|---------|-------------|------|---------|-------|-------|-----|-----|----------|-------|--|
| Port      | Service | Clk         | Rate | Frame   | LLB   | DTR   | DTR | RTS | Loopback | Alarm |  |
| 1         | IS      | Int         | 32   | Unframe | Check | Check | OFF | OFF | None     | LOS   |  |
| 2         | IS      | Int         | 32   | Unframe | Check | Check | OFF | OFF | None     | LOS   |  |
| 3         | IS      | Int         | 32   | Unframe | Check | Check | OFF | OFF | None     | LOS   |  |
| 4         | IS      | Int         | 32   | Unframe | Check | Check | OFF | OFF | None     | LOS   |  |

Press 'r': refresh, '<' or '>': select item, 'ESC': exit

For Ethernet interface, you will get:

| Item: S-4 |         | Class: QSW |      |           |           |          |         |  |  |
|-----------|---------|------------|------|-----------|-----------|----------|---------|--|--|
| Port      | Service | Link Ctrl  | Link | Speed     | Flow Ctrl | Priority | Alarm   |  |  |
| 1         | IS      | AutoNeg    | Up   | 100M Full | no        | 0        | ---     |  |  |
| 2         | IS      | AutoNeg    | Down | 10M Half  | no        | 0        | LNK DWN |  |  |
| 3         | IS      | AutoNeg    | Down | 10M Half  | no        | 0        | LNK DWN |  |  |
| 4         | IS      | AutoNeg    | Down | 10M Half  | no        | 0        | LNK DWN |  |  |
| WAN       | IS      | AutoNeg    | Up   | 100M Full | no        | 0        | ---     |  |  |

Press 'r': refresh, '<' or '>': select item, 'ESC': exit

### 2. General Settings:

Here you can set optical protection switch to "Non-Revertive" or "Revertive", set the WTR Delay time based on fiber signal fail (LOS, LOF), and even setup the BER threshold to do APS switch. All of this optical line protection is defined in ITU-T Rec. G.783.

| [ General Configuration ]                |           |
|--|-----------|
| << Optical Interface >>                  |           |
| Optical Protection Switch: Non-Revertive |           |
| Wait To Restore(min): 0                  |           |
| Switch Threshold: 3                      |           |
| Threshold Scale: 10^-5                   |           |
| < Save >                                 | < Abort > |

## Appendix B. Menu-Driven Operations

### 3. Optical Interface:

| <b>** Detected **</b><br>West - OPT<br>East - OPT   | Apply to ..... Current<br>Apply to Port..... 1<br>Service State..... In Service<br>PM Threshold Alarm..... Disable<br>ALS (G. 958/G. 664)..... Disable<br>ALS Restart Delay(sec).. 300 |       |        |        |        |       |        |        |        |     |      |     |    |    |      |     |    |    |      |      |     |     |    |      |     |     |    |     |        |       |      |      |        |       |      |      |  |
|---|--|-------|--------|--------|--------|-------|--------|--------|--------|-----|------|-----|----|----|------|-----|----|----|------|------|-----|-----|----|------|-----|-----|----|-----|--------|-------|------|------|--------|-------|------|------|--|
| <table border="1" style="width: 100%; border-collapse: collapse;"> <thead> <tr> <th></th> <th>L. CV</th> <th>L. ES</th> <th>L. SES</th> <th>L. UAS</th> <th>P. CV</th> <th>P. ES</th> <th>P. SES</th> <th>P. UAS</th> </tr> </thead> <tbody> <tr> <td>Qtr</td> <td>1400</td> <td>180</td> <td>45</td> <td>18</td> <td>1353</td> <td>180</td> <td>45</td> <td>18</td> </tr> <tr> <td>Hour</td> <td>5600</td> <td>720</td> <td>180</td> <td>72</td> <td>5412</td> <td>720</td> <td>180</td> <td>72</td> </tr> <tr> <td>Day</td> <td>134400</td> <td>17280</td> <td>4320</td> <td>1728</td> <td>129890</td> <td>17280</td> <td>4320</td> <td>1728</td> </tr> </tbody> </table> |  | L. CV | L. ES  | L. SES | L. UAS | P. CV | P. ES  | P. SES | P. UAS | Qtr | 1400 | 180 | 45 | 18 | 1353 | 180 | 45 | 18 | Hour | 5600 | 720 | 180 | 72 | 5412 | 720 | 180 | 72 | Day | 134400 | 17280 | 4320 | 1728 | 129890 | 17280 | 4320 | 1728 |  |
|   | L. CV  | L. ES | L. SES | L. UAS | P. CV  | P. ES | P. SES | P. UAS |        |     |      |     |    |    |      |     |    |    |      |      |     |     |    |      |     |     |    |     |        |       |      |      |        |       |      |      |  |
| Qtr   | 1400   | 180   | 45     | 18     | 1353   | 180   | 45     | 18     |        |     |      |     |    |    |      |     |    |    |      |      |     |     |    |      |     |     |    |     |        |       |      |      |        |       |      |      |  |
| Hour  | 5600   | 720   | 180    | 72     | 5412   | 720   | 180    | 72     |        |     |      |     |    |    |      |     |    |    |      |      |     |     |    |      |     |     |    |     |        |       |      |      |        |       |      |      |  |
| Day   | 134400   | 17280 | 4320   | 1728   | 129890 | 17280 | 4320   | 1728   |        |     |      |     |    |    |      |     |    |    |      |      |     |     |    |      |     |     |    |     |        |       |      |      |        |       |      |      |  |
| Press 'r' : refresh, 'l' : load default, 's' : save, 'Esc' : exit   |  |       |        |        |        |       |        |        |        |     |      |     |    |    |      |     |    |    |      |      |     |     |    |      |     |     |    |     |        |       |      |      |        |       |      |      |  |

On this page you can edit the service state to "IS" (In Service) or "OOS" (out of service), enable or disable TCA report, enable or disable ALS mode, set the delay time in seconds of ALS, and set the threshold values for performance alarms.

At any time you can press "r" to reload settings, "l" to load default values, "s" to save the changes or "Esc" to exit without saving.

### 4. E1 Interface:

| <b>** Detected **</b><br>S-1 - 8E1R<br>S-3 - QE1B   | Apply to Port..... Current<br>Apply to Port..... 1<br>Service State..... In Service<br>PM Threshold Alarm..... Disable<br>Mode..... E1<br>Coding..... HDB3/B8ZS<br>Frame..... Unframe<br>Impedance..... 120<br>LBO.....<br>LBO..... |       |        |        |        |       |        |        |        |     |     |     |    |    |     |     |    |    |      |      |     |     |    |      |     |     |    |     |       |       |      |      |       |       |      |      |  |
|---|---|-------|--------|--------|--------|-------|--------|--------|--------|-----|-----|-----|----|----|-----|-----|----|----|------|------|-----|-----|----|------|-----|-----|----|-----|-------|-------|------|------|-------|-------|------|------|--|
| <table border="1" style="width: 100%; border-collapse: collapse;"> <thead> <tr> <th></th> <th>L. CV</th> <th>L. ES</th> <th>L. SES</th> <th>L. UAS</th> <th>P. CV</th> <th>P. ES</th> <th>P. SES</th> <th>P. UAS</th> </tr> </thead> <tbody> <tr> <td>Qtr</td> <td>369</td> <td>180</td> <td>45</td> <td>18</td> <td>415</td> <td>180</td> <td>45</td> <td>18</td> </tr> <tr> <td>Hour</td> <td>1475</td> <td>720</td> <td>180</td> <td>72</td> <td>1659</td> <td>720</td> <td>180</td> <td>72</td> </tr> <tr> <td>Day</td> <td>35400</td> <td>17280</td> <td>4320</td> <td>1728</td> <td>39813</td> <td>17280</td> <td>4320</td> <td>1728</td> </tr> </tbody> </table> |   | L. CV | L. ES  | L. SES | L. UAS | P. CV | P. ES  | P. SES | P. UAS | Qtr | 369 | 180 | 45 | 18 | 415 | 180 | 45 | 18 | Hour | 1475 | 720 | 180 | 72 | 1659 | 720 | 180 | 72 | Day | 35400 | 17280 | 4320 | 1728 | 39813 | 17280 | 4320 | 1728 |  |
|   | L. CV   | L. ES | L. SES | L. UAS | P. CV  | P. ES | P. SES | P. UAS |        |     |     |     |    |    |     |     |    |    |      |      |     |     |    |      |     |     |    |     |       |       |      |      |       |       |      |      |  |
| Qtr   | 369   | 180   | 45     | 18     | 415    | 180   | 45     | 18     |        |     |     |     |    |    |     |     |    |    |      |      |     |     |    |      |     |     |    |     |       |       |      |      |       |       |      |      |  |
| Hour  | 1475  | 720   | 180    | 72     | 1659   | 720   | 180    | 72     |        |     |     |     |    |    |     |     |    |    |      |      |     |     |    |      |     |     |    |     |       |       |      |      |       |       |      |      |  |
| Day   | 35400   | 17280 | 4320   | 1728   | 39813  | 17280 | 4320   | 1728   |        |     |     |     |    |    |     |     |    |    |      |      |     |     |    |      |     |     |    |     |       |       |      |      |       |       |      |      |  |
| Press 'r' : refresh, 'l' : load default, 's' : save, 'Esc' : exit   |   |       |        |        |        |       |        |        |        |     |     |     |    |    |     |     |    |    |      |      |     |     |    |      |     |     |    |     |       |       |      |      |       |       |      |      |  |

On this page you can set the interface service state to "IS" (in service) or "OOS" (out of service), enable or disable TCA report, set the line coding and set the Threshold values for the performance parameters for Qtr (15 minute), Hour and Day.

At any time you can press "r" to reload settings, "l" to load default values, "s" to save the changes or "Esc" to exit without saving.

## Appendix B. Menu-Driven Operations

### 5. V.35 Interface:

|                |                          |             |
|----------------|--------------------------|-------------|
| ** Detected ** | Apply to .....           | Current     |
| S-2 - QV35     | Apply to Port.....       | 1           |
|                | Service State.....       | In Service  |
|                | Clock Mode.....          | Internal    |
|                | Data Rate.....           | 32          |
|                | Framing Mode.....        | Unframe     |
|                | LLB Signal.....          | Normal      |
|                | DTR Signal.....          | Normal      |
|                | V.54 (RDL) Detection.... | Disable     |
|                | Time to Release(Min).... | 5           |
|                | Interface Mode.....      | DCE-DTE     |
|                | Tx Data Output Edge....  | Rising Edge |

Press 'r': refresh, 'l': load default, 's': save, 'Esc': exit

On this page you can set the service state as "IS" or "OOS", set the clock mode, set the Data rate, set framing mode, enable V.54 detection, and set to ignore DTR or LLB signals. DTR and LLB signals are from V.35 DTE, but some DTE do not provide them. You can also set "Ignore" to ignore V.35 alarms caused by DTR or LLB signals.

At any time you can press "r" to reload settings, "l" to load default values, "s" to save the changes or "Esc" to exit without saving.

### 6. Ethernet Interface:

|                       |                    |                      |         |
|-----------------------|--------------------|----------------------|---------|
| ** Detected **        | Apply to .....     | Current              |         |
| S-4 - QSW             | Apply to Port..... | 1                    |         |
|                       | Service State..... | In Service           |         |
|                       | Link Control.....  | Auto-Negotiation     |         |
| Flow Control.....     | Disable            | Ingress Rate.....    | Disable |
| Default Priority..... | 0                  | Rate.....            | 100M    |
| Double VLAN Tag.....  | Disable            | Flow Control.....    | Disable |
| Provider Tag.....     | 0000.              | Unknown Unicast....  | limit   |
|                       |                    | Unknown Broadcast... | limit   |
|                       |                    | Unicast.....         | limit   |
| Default VLAN ID.....  | 0000.              | Multicast.....       | limit   |
| Force VID.....        | Disable            | Broadcast.....       | limit   |
| VLAN Port Mode.....   | 802.1Q Disable     | MGMT Frames.....     | limit   |
| Egress Tag.....       | Unmodified         | ARP.....             | limit   |
| Ingress Tag.....      | None               | Bucket Increment.... | ae.     |
| Egress Rate .....     | 100M               | CBS Limit.....       | 060000. |
|                       |                    | EBS Limit.....       | fffff0. |

Press 'r': refresh, 'l': load default, 's': save, 'Esc': exit

On this page you can set the service state, speed rate, set flow control, Default Priority, Double VLAN tag, Default VLAN ID, Egress Rate and Ingress Rate Settings.

The user can set more advanced functions like enabling flow control or limiting the traffic according the traffic-type like broadcast frames or ARP. Also the user can set other parameters like Committed Burst size (CBS) and/or Excess Burst size (EBS).

Note: Only change the default values if you are sure of the values to configure. Wrong configuration will lead to unpredictable results.

## Appendix B. Menu-Driven Operations

### More on configuring Ethernet

When enabling Flow control, there is flow control at the ingress rate configured and no packet loss will happen. Usually this option should be disabled. If flow control in Ingress rate is enabled, be sure that you have set flow control for this port in the second option for the global QSW menu. If this is not the case ingress rate won't work.

The scheme for implementing ingress rate limiting is a leaky bucket. Imagine a bucket that drains tokens constantly at a rated called Committed Information Rate (CIR) (Rate option in the menu) and the bucket gets replenished with tokens whenever frames are allowed to go through the bucket. All calculations for this bucket are carried out in tokens.

Bucket Increment (Hex) controls how many tokens need to get added after accepting each frame. It is recommended that this value be 0xAE.

EBS\_limit is directly proportional to the amount of bytes that can be accommodated as part of the frame burst. Recommended value = 0xFFFFF0.

CBS\_limit signifies the minimum token depth necessary to allow frames go through. Recommended value = 0x060000.

Next figure explains better the concept of a leaky bucket:

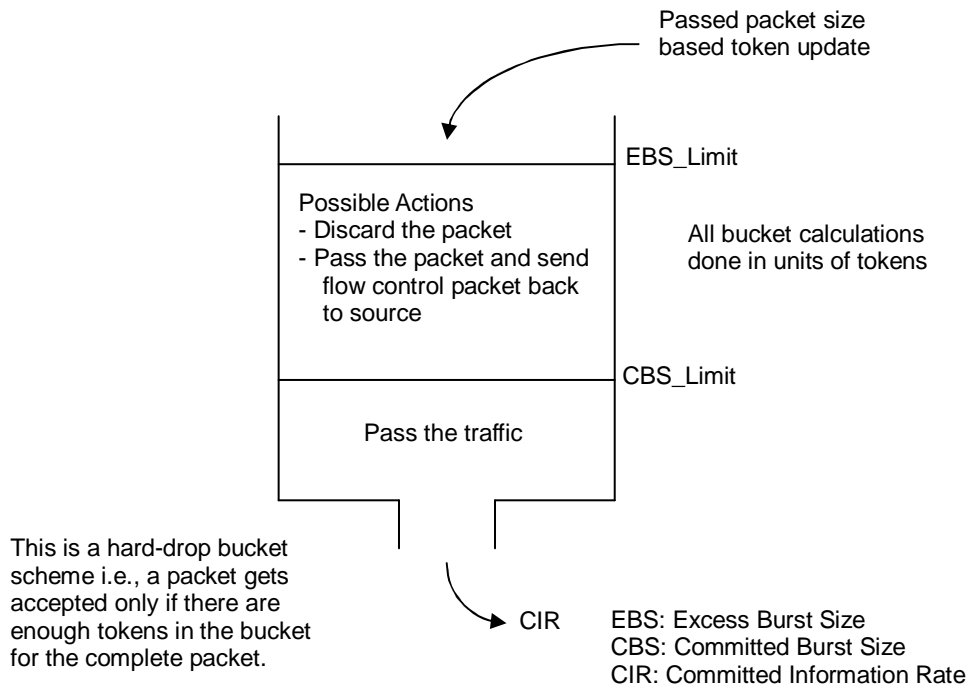



## Appendix B. Menu-Driven Operations

### Port Trunking:

```
** Detected **
S-4 - QSW
Port 1 is assigned to... none
Port 2 is assigned to... none
Port 3 is assigned to... none
Port 4 is assigned to... none

          +-----+
          | P1 | P2 | P3 | P4 |
          +-----+

G1
G2

Press 'r': refresh, 'l': default, 's': save, 'Esc': exit
```

You can edit the port trunking setting here by using Arrow keys.

At any time you can press "r" to reload setting, "l" to load default values, "s" to save the changes or "Esc" to exit without saving.

### Port-Based VLAN:

```
** Detected **
S-4 - QSW
Port  1   2   3   4  WAN
-----
1      V   V   V   V
2  V      V   V   V
3  V   V      V   V
4  V   V   V      V

Press 'r': refresh, ' ': modify, 'l': default, 's': save, 'Esc': exit
```

You can edit the port-based VLAN setting here by using Arrow keys and SPACE key.

At any time you can press "r" to reload setting, "l" to load default values, "s" to save the changes or "Esc" to exit without saving.

Tagged VLAN:

```

** Detected **
S-4 - QSW
VIDs
0001
0023
Rate Limit : unlimit
Description:
802.1Q Egress Tag:
Port 1: Not member
Port 2: Not member
Port 3: Not member
Port 4: Not member

Press 'r': refresh, 'a': add, 'd': delete, 's': save modified, 'Esc': exit
    
```

You can edit the tagged VLAN setting of QSW.

At any time you can press "r" to reload setting, "l" to load default values, "s" to save the changes or "Esc" to exit without saving.

### 8. Cross Connect Tab:

```

<< Digital Cross Connect Table >>
CH: K L M CH: K L M CH: K L M CH: K L M
1 [1 1 1] 17 [2 6 1] 33 [3 4 2] 49 [1 3 3]
2 [2 1 1] 18 [3 6 1] 34 [1 5 2] 50 [2 3 3]
3 [3 1 1] 19 [1 7 1] 35 [2 5 2] 51 [3 3 3]
4 [1 2 1] 20 [2 7 1] 36 [3 5 2] 52 [1 4 3]
5 [2 2 1] 21 [3 7 1] 37 [1 6 2] 53 [2 4 3]
6 [3 2 1] 22 [1 1 2] 38 [2 6 2] 54 [3 4 3]
7 [1 3 1] 23 [2 1 2] 39 [3 6 2] 55 [1 5 3]
8 [2 3 1] 24 [3 1 2] 40 [1 7 2] 56 [2 5 3]
9 [3 3 1] 25 [1 2 2] 41 [2 7 2] 57 [3 5 3]
10 [1 4 1] 26 [2 2 2] 42 [3 7 2] 58 [1 6 3]
11 [2 4 1] 27 [3 2 2] 43 [1 1 3] 59 [2 6 3]
12 [3 4 1] 28 [1 3 2] 44 [2 1 3] 60 [3 6 3]
13 [1 5 1] 29 [2 3 2] 45 [3 1 3] 61 [1 7 3]
14 [2 5 1] 30 [3 3 2] 46 [1 2 3] 62 [2 7 3]
15 [3 5 1] 31 [1 4 2] 47 [2 2 3] 63 [3 7 3]
16 [1 6 1] 32 [2 4 2] 48 [3 2 3] T-S?P? TDM traffic

Press 'r': refresh, 'c/d': clean/remove, 'l': default, 's': save, 'Esc': exit
    
```

This page is one of the most important for configuring the tributary channels and EoS mapped to the STM-1 VC12 circuits. Use the [Space] key to select Slot and Port channel for each VC (1 to 63). Use arrow keys to navigate to different VCs.

At any time you can press "r" to reload setting, 'c' to remove all assignments, 'd' to remove current assignment, "l" to load default values, "s" to save the changes or "Esc" to exit without saving.

### 9. Default Settings:

Use this screen to load default configurations. Enter the menu through "Configuration" -> "Default Settings".

```
[ Load Default Configuration ]
[ ] West - OPT
[ ] East - OPT
[ ] S-1 - 8E1R
[ ] S-2 - QV35
[ ] S-3 - QE1B
[ ] S-4 - QSW
< OK >          < Cancel >
```

Use Space Key to change the selection. After "OK" executed, the system will response success or not.

## IV. Diagnosis Tools

There are "Protection SW", "ALS (G.958/G.664)", "Laser Power Test", "Loopback Operation", "Tributary Diagnosis" and "V.54 Diagnosis" sub menus under the Diagnostic Tools.

1. Protection SW
2. ALS (G. 958/G. 664)
3. Laser Power Test
4. Loopback Operation
5. Tributary Diagnosis
6. V.54 Diagnosis
0. Previous Menu

### 1. Manual fiber Protection SW:

Operate manually the optical protection switch by software. Enter through the menu as follows. Select the switching method.

```
[ Manual Protection Switch ]
Direction: switch to West
Priority: Normal
< OK >          < Cancel >
```

There are both Direction and Priority parameters.

Direction options: "Switch to West", "Switch to East"

Priority options: "Normal", "Lock"

The operation is done after "OK" executed.

## Appendix B. Menu-Driven Operations

### 2. ALS (G.958/G.664):

This screen operates the manual start of ALS. Enter through "Diagnosis Tools" -> "ALS (G.958/G.664)".

```

+-----+
| [ Manual Laser Restart ] |
| Laser: restart ( 2s) |
+-----+
| < OK >      < Cancel > |
+-----+

```

Restart Type options: restart 2s (laser output lasting for 2 seconds), restart 90s (laser output lasting for 90 seconds).

### 3. Laser Power Test:

This screen operates the laser power test. Enter through "Diagnosis Tools" -> "Laser Power Test".

CAUTION: Transmissions will be halted during this test.

```

+-----+
| ** Detected ** | Note: This operation will set device OOS temporarily. |
| West - OPT     | Please make sure ALS is enabled at remote node, |
| East - OPT     | otherwise the laser power test will fail. |
|               | T1 ( 500-800 ms)..... > 3 sec |
|               | T2 ( 60-300 s)..... |
|               | T3 (1.75-2.2 s)..... |
|               | T4 ( <850 ms)..... |
+-----+
| Tx PWR        | _____ |
| Enable        | \_____ / |
|               | |<- T1 ->|<- T2 ->|<- T3 ->| |<- T4 ->| |
| Rx Signal     | _____ |
|               | \_____ / |
+-----+
| Press 'r' : refresh list, 's' : start to test/stop testing, 'Esc' : exit |
+-----+

```

At any time you can press "r" to refresh the list, "s" to start the test or "Esc" to exit without saving. This function can let the user test remote SDH01A ALS function from local SDH01A console. The user can get T1 /T2 /T3 /T4 period to make sure if remote SDH01A meets ITU G.958 or G.664 spec. from console easily.

## Appendix B. Menu-Driven Operations

### 4. Loop back Operation:

This screen operates the loop back functions. Enter through "Diagnosis Tools" -> "Loopback Operation".

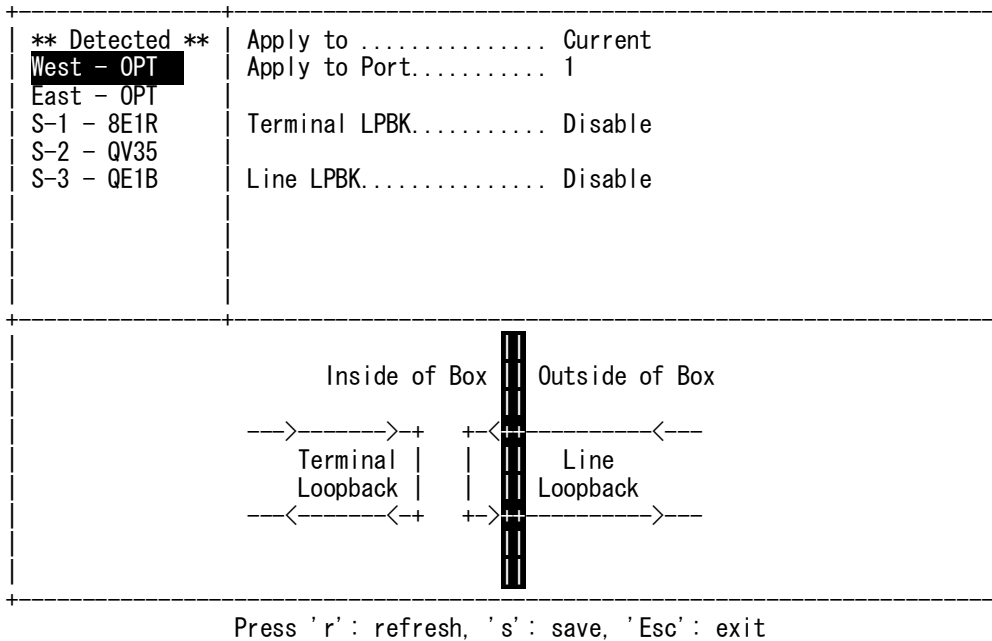

At any time you can press "r" to reload setting, "s" to save the changes or "Esc" to exit without saving.

### 5. Tributary Diagnostics:

To Implement E1 self-diagnostic test, enter through "Diagnosis Tools" -> "Tributary Diagnosis".

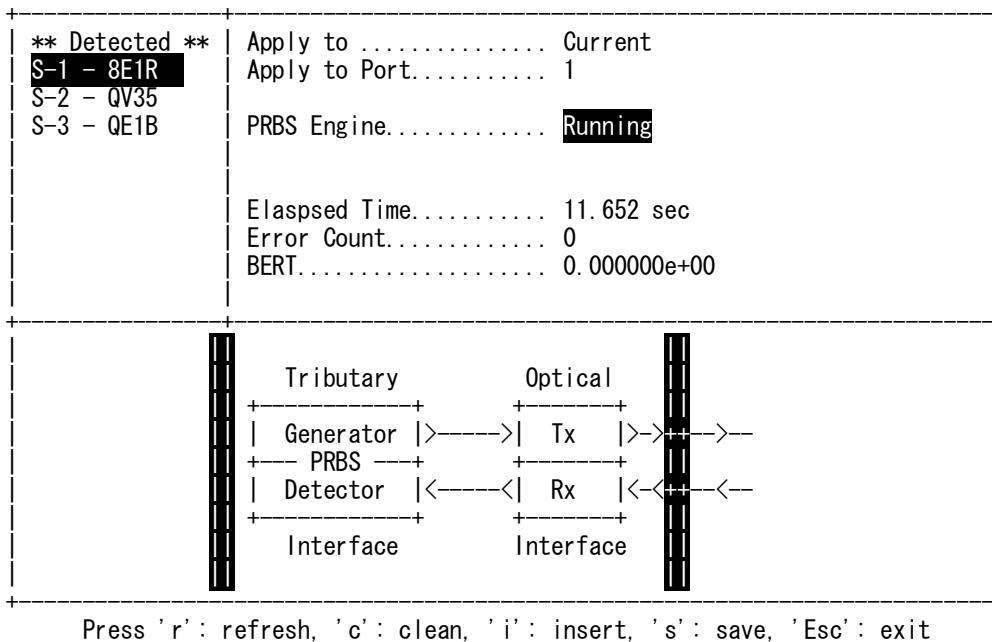

The above example illustrates the BER test on Slot 1 Port 1, an E1 channel.

At any time you can press "r" to reload setting, "c" to reset counter, "i" to insert a error, "s" to save the changes or "Esc" to exit without saving.

## Appendix B. Menu-Driven Operations

### 6. V.54 Diagnostics:

To implement V.35 self-diagnostic test, enter through "Diagnosis Tools" -> "V.54 Diagnosis".

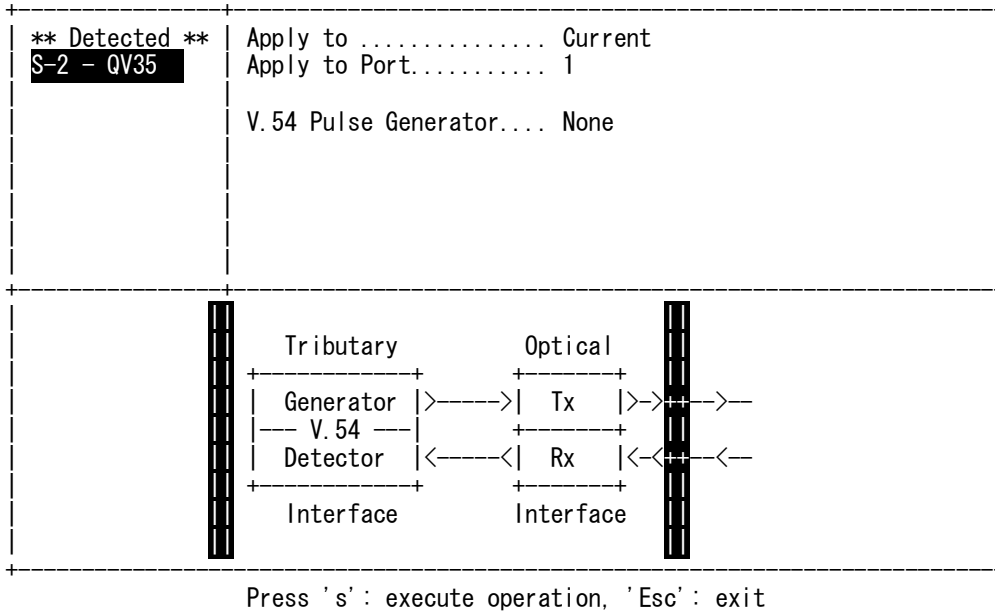

Please press "s" to execute the command or "Esc" to exit without saving.

## V. System Settings

There are "System Information", "Network Configure", "Date and Time", "Upgrade System", "Audible Setting", "Synchronous Timing", "Configure Backup", and "System Reset" sub menus under the System Settings.

1. System Information
2. Network Configure
3. Date and Time
4. Upgrade System
5. Audible Setting
6. Synchronous Timing
7. Configure Backup
8. System Reset
0. Previous Menu

### 1. System Information:

Used to retrieve the version of equipment and show the version information.

```

<<   System Information   >>
-----
Item      Number      Build
-----
F/W       1.3A      07/31/08 16:22
H/W       8.8
EPLD     1.0
FPGA     ad.16     07/01
S/N      8800082200A3B
MAC      00:02:ab:f0:0a:3b

```

---

```

System Uptime..... 5:30:20

```

Press 'r': refresh, 'ESC': exit

## Appendix B. Menu-Driven Operations

### 2. Network Configure:

Set the IP address of the equipment. Enter through "System Settings" -> "Network Configure". The following options are available

- 1. Host Network
- 2. SNMP Trap IP
- 3. SNMP Setting
- 0. Previous Menu

#### Host Network

Input the IP address, Netmask, and Gateway or Enable DHCP client. Then press [Enter] to complete the setting.

```
+-----+
| [ Host Network ] |
|          |
| DHCP: Disable |
| Host IP: 192.168.0.161 |
| Netmask: 255.255.255.0 |
| Gateway: 192.168.0.254 |
|          |
| < Save >      < Abort > |
+-----+
```

#### SNMP Trap IP:

Input the Trap IP 1 address, Trap IP 2, and Trap IP 3. Then press [Enter] to complete the setting.

```
+-----+
| [ SNMP Trap IP ] |
|          |
| Trap IP #1: 192.168.0.73 |
| Trap IP #2: 192.168.0.223 |
| Trap IP #3: 0.0.0.0 |
|          |
| < Save >      < Abort > |
+-----+
```

#### SNMP Community:

Input the Get (Read-only) Community, and Set (Write) Community. Then press [Enter] to complete the setting.

```
+-----+
| [ SNMP Setting ] |
|          |
| Get Community( public): |
| Confirm Get Community  : |
|          |
| Set Community( private): |
| Confirm Set Community   : |
|          |
| < Save >      < Abort > |
+-----+
```

## Appendix B. Menu-Driven Operations

### 3. Set Date/Time:

Set the date of the system. Enter through "System Settings" -> "Date and Time".  
Select the date and time to set.

```
[ Modify Date/Time ]
Date (M/D/Y) : 08/22/2008
Time (H/M/S) : 17:34:35
[ < Save >          < Abort > ]
```

The user can modify the Date/Time by editing the data. Then press [Enter] to complete the setting.

### 4. Upgrade System

The following options are available under upgrade system:

- 1. TFTP Upgrade
- 2. Terminal Mirror
- 0. Previous Menu

#### TFTP Upgrade:

This option lets the user upgrade software using tftp server. The user must specify the IP address of the tftp server and the name of the file containing the software to upgrade:

```
[ Upgrade by TFTP ]
TFTP Server IP: 192.168.0.251
File Name: upgrade.tar.gz
default file : (upgrade.tar.gz)
[ < OK >          < Cancel > ]
```

Once <OK> is pressed the upgrade will proceed. It will take around 1 minute to complete.

#### Mirror Upgrade:

This option lets the user mirror software from node to node (remote upgrade). The user needs specify the mirror direction from/to local side by ←→:

```
Local Side ==> 192.168.0.212
1. 192.168.0.212 remote node
A ==> B: copy files from node A to node B
Press 'r': refresh, '<->': direction, 's': start, 'Esc': exit
```

Once "s" is pressed the upgrade will proceed. It will take around 3 minutes to complete a remote upgrade.

## Appendix B. Menu-Driven Operations

### 5. Audible:

This screen sets the mode of audible office alarm. Enter through "System Settings" -> "Audible Setting". Then select the mode.

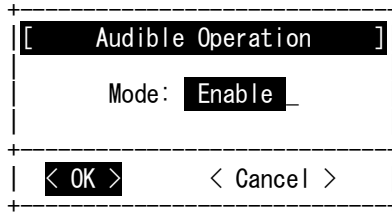

```
[ Audible Operation ]
Mode: Enable
< OK >    < Cancel >
```

The mode setting include:

Disable: Disable this function;

Enable: Enable this function;

Cut Off: Turn off the sound. It will sound again if new alarm occurs.

### 6. Synchronous Timing:

This screen sets the mode of system clock. Enter through "System Settings" -> "Synchronous Timing". Then select the mode.

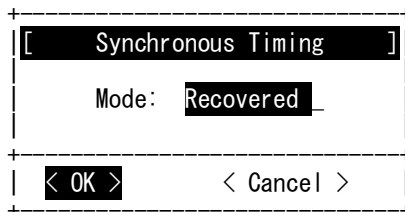

```
[ Synchronous Timing ]
Mode: Recovered
< OK >    < Cancel >
```

The mode settings include:

Free-Run: internal oscillator

Recovered: system recovers clock from optical interface.

### 7. Reset System

Enter this screen to do a system reset. Enter through "System Settings" -> "System Reset".

Select the reset method and then press [Enter] to execute the command.

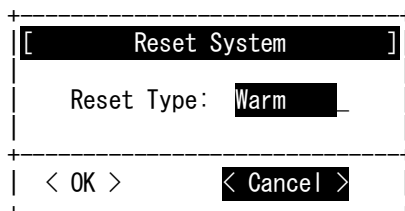

```
[ Reset System ]
Reset Type: Warm
< OK >    < Cancel >
```

There are two available reset options as follows.

Warm: reset the system software without interrupting traffic. (Same as the RST button on the front panel)

Cold: reset the system hardware. It will impact the traffic.

Restore: When this option is taken, a cold start is performed and the backup system will be resorted after the restart.

## VI. Account Management

```

+-----+
| * Account * | [current user] you can not edit your ability.
| root       |
| optical    | == Ability of Account ==
|            | [*] Configurations
|            | [*] System Settings
|            | [*] Diagnosis Tools
|            | [*] Account Management
|            | [ ] Debug Tools
+-----+
Press 'a': create, 'd': delete, 'm': modify, 's': save, 'ESC': exit
  
```

All user accounts will be shown in the left window. You can change account permissions in the right window. At any time you can press "a" to popup account creation window, "d" to popup account deletion window, "m" to popup account modification window, "s" to save the changes or "Esc" to exit without saving.

### 1. Add User Account

When selecting the "a" account creation, a popup window will appear. Fill in the user information, including name, password, confirm password and description.

```

+-----+
| * Account * | [current user] you can not edit your ability.
| root       |
| optical    | == Ability of Account ==
|            | [*] Configurations
|            | [*] Syst+
|            | [*] Diag [ Create New Account ]
|            | [*] Acco
|            | [ ] Debu
+-----+
|            | Account:
|            | Password:
|            | Confirm:
|            | Description:
+-----+
|            | < Create >      < Abort >
+-----+
Press 'a': create, 'd': delete, 'm': modify, 's': save, 'ESC': exit
  
```

The user is added after "Create" is executed.

## Appendix B. Menu-Driven Operations

### 2. Del User Account

When selecting the "d" deletion creation, a popup window will appear.

```
+-----+
| * Account * | [operator] oper
+-----+
| root
| optical
| operator    | == Ability of Account ==
|             | [ ]Configurations
|             | [ ]Syst
|             | [ ]Diag [ Delete Account ]
|             | [ ]Acco
|             | [ ]Debu
+-----+
|                                     |
|               Are you sure to delete |
|               account 'operator' ?  |
|                                     |
| < Delete >   < Abort >             |
+-----+

Press 'a': create, 'd': delete, 'm': modify, 's': save, 'ESC': exit
```

After "Delete" is executed, the user is deleted.

### 3. Edit User Account

Select the user name you want to edit. When selecting the "m" account modify, a popup window will appear. Then edit the data of the user.

```
+-----+
| * Account * | [current user] you can not edit your ability.
+-----+
| root
| optical
|             | == Ability of Account ==
|             | [*]Configurations
|             | [*]Syst
|             | [*]Diag [ Modify Account ]
|             | [*]Acco
|             | [ ]Debu
+-----+
|                                     |
|               Account: root        |
|               Password:            |
|               Confirm:             |
|               Description: enance  |
|               account              |
|                                     |
| < Save >   < Abort >             |
+-----+

Press 'a': create, 'd': delete, 'm': modify, 's': save, 'ESC': exit
```

Execute "SAVE" to complete the editing after data input.

## VII. Node Access

Under Node Access, the following options are available:

- 1. Node Selection
- 2. Node Description
- 0. Previous Menu

### 1. Node Selection

Under Node settings, set the site, local side or remote side, to manage by the Menu-Driven interface.

```

+-----+
|               <<  Node Selection  >>               |
+-----+
|          LO. 192.168.0.161  Local Node          |
|          RM. 192.168.0.162  Remote Node          |
+-----+
|  E                                     Connection Topology  |
| Local                                     |
| W----- 1 |
+-----+
Press 'r': refresh, 'ENTER': select, 'Esc': exit

```

Press ↑↓ to select Local or Remote site. The name of site is shown on the top of the menu window to indicate the site under management. All the operations are done to this site after selection.

### 2. Node Description

Use this setup screen to give the SDH01A a system name. Edit the node field.

```

+-----+
| [ Node Description ] |
| Node: 161-C0         |
+-----+
| < Save >           < Abort > |
+-----+

```

Execute "SAVE" to complete the save after data input.

## Appendix C. LCD Operations

This section will explain the operations of the LCD interface.

The LCD has two rows and can display up to 16 characters per row on the panel.

UR: Upper Row; BR: Bottom Row

|   |   |   |   |   |   |   |   |   |   |   |   |
|---|---|---|---|---|---|---|---|---|---|---|---|
| S | D | H | 0 | 1 | A |   |   |   |   |   |   |
| 1 | 9 | 2 | . | 1 | 6 | 8 | . | 0 | . | 7 | 3 |

There are four keypads under the LCD panel: [ESC] [←] [ENT+] [⇒]

[ESC]: return to the previous view or abandon current operation

[←][⇒]: move cursor or select parameter

[ENT+]: select, execute, or change number

### I. Operating Procedures:

UR is the previous hierarchy items of BR. Use [←] or [⇒] to move and [ENT+] to select the item of BR. The item selected will show on UR. The number on the left is the position in the hierarchy. The character on the right of BR reminds you the next keypad to operate.

### II. Key Lock Protection:

LCD is protected by key lock. After booting or if no key is pressed within 10 minutes, LCD will enter key lock mode. Unless you input the correct password, LCD will remain in key lock mode and enter normal operation mode. The default password is "6666". You can change the password by pressing [ENT+] and [⇒] at the same time in welcome display (LCD shows model name and host IP). [ENT+] and [ESC] at the same time in welcome display can force LCD to enter key lock mode immediately.

|   |   |   |   |   |   |   |   |   |   |   |   |   |   |   |   |
|---|---|---|---|---|---|---|---|---|---|---|---|---|---|---|---|
| K | E | Y | L | O | C | K | : |   |   |   |   |   |   |   |   |
| < | 0 | 1 | 2 | 3 | 4 | 5 | 6 | 7 | 8 | 9 | a | b | c | d | > |

Press the 'right arrow' key until the cursor is over the "6" character. Press the 'ENT+' key 4 times to login.

|   |   |   |   |   |   |
|---|---|---|---|---|---|
| S | D | H | 0 | 1 | A |
| * | L | O |   |   |   |

Once logged on, the user may select either the Local unit for configuration or the ReMote unit.

|   |   |   |   |   |   |
|---|---|---|---|---|---|
| L | O |   |   |   |   |
| < |   | A | L | M | > |

This screen shows the main menu; the top of the hierarchy in the menu scheme.

### III. The Function Menu List:

ALM: (Alarm Management)

VIEW

CURR/HIST

ALL/SYS/OPT/E1/V35/ETH

RST

CURR/HIST

SEVER

OPT

LOS : CRITICAL / MAJOR / MINOR / EVENT

LOF : CRITICAL / MAJOR / MINOR / EVENT

AIS : CRITICAL / MAJOR / MINOR / EVENT

RDI : CRITICAL / MAJOR / MINOR / EVENT

E1

LOS : CRITICAL / MAJOR / MINOR / EVENT

AIS : CRITICAL / MAJOR / MINOR / EVENT

RDI : CRITICAL / MAJOR / MINOR / EVENT

V35

LOS : CRITICAL / MAJOR / MINOR / EVENT

AIS : CRITICAL / MAJOR / MINOR / EVENT

RDI : CRITICAL / MAJOR / MINOR / EVENT

ETH

LNKDWN: CRITICAL / MAJOR / MINOR / EVENT

PM: (Performance Data)

VIEW

OPT

Curr/Prev

QTR/HOUR/DAY

Line

LCV/LES/LSES/LUAS

Path

PCV/PES/PSES/PUAS

E1

Port Number

Curr/Prev

QTR/HOUR/DAY

Line

LCV/LES/LSES/LUAS

Path

PCV/PES/PSES/PUAS

RST

Curr/All

RMON

Slot Number

{RMON Data}

RMONRST

Slot Number

## Appendix C. LCD Operations

---

All/1/2/3/4/WAN

CFG: (Configuration)

SMRY

OPT

SVC: IS / OOS

ALS: Enable / Disable

DELAY: 60~300 sec

LPBK: None / Line / Term

E1

SVC: IS / OOS

MODE: E1

CODE: HDB3 /AMI

FRAME: Unframe

IMPED: 75-ohm / 120-ohm

LBD:-----

V35

SVC: IS / OOS

REF: Internal / External / Recovery

RATE: 1~32

FRAME: Unframe / PCM-31C / PCM-30C / PMC-31 / PMC-30

LLB: Normal/ Ignore

DTR: Normal/ Ignore

DTR: OFF / ON

RTS: OFF / ON

LPBK: None / Line / Term

ETH

SVC: IS / OOS

LINK: Up / Down

SPEED: 10M / 100M

DUPLEX: Half / FULL

FLOW: OFF / ON

PRIO: 0~3

GNAL

PSW: Revert / Non-Revert

WTR: 0~15 Min.

SWTCA: 1~9

SWSCALE: 10-5~10-9

OPT

ALL / 1

SVC: IS / OOS

TCARPT: Enable /Disable

ALS: Enable /Disable

DELAY: 60~300 sec

TCA

E1

ALL 1 2 3 4

SVC: IS / OOS

TCARPT: Enable /Disable

MODE: E1  
CODING: HDB3/AMI  
FRAME: Unframe  
IMPED:75-ohm  
LBO: -----  
TCA  
V35  
ALL 1 2 3 4  
SVC: IS / OOS  
CLK: Internal / External / Recovery  
FRAME: Unframe / PCM-31C / PCM-30C / PCM-31 / PCM-30  
RATE: 1~32  
LBK: Normal / Ignore  
DTR: Normal / Ignore  
ETH  
ALL 1 2 3 4 WAN  
CFG  
SVC: IS / OOS  
FLOW: Enable /Disable  
PRIO: 0~4  
VLAN  
DBVLAN: Enable /Disable  
PROVIDER: 0000~FFFF  
DEF-VID: 0~4095  
FORCE-VID: Enable /Disable  
VLANPORT: 802.1Q Disable / Fallback / Check / Secure  
EG-TAG: Unmodified / Untagged / Tagged  
ING-TAG: None / Drop Untagged / Drop Tagged  
EGRESS  
EgressRate: 64K~100M  
INGRESS  
ING-ENA: Enable /Disable  
ING-RATE: 64K~100M  
ING-FLOW: Enable /Disable  
UNKUNICAST: Unlimit / limit  
UNKBCAST: Unlimit / limit  
UNKICAST: Unlimit / limit  
MULTICAST: Unlimit / limit  
BCAST: Unlimit / limit  
MGMT: Unlimit / limit  
ARP: Unlimit / limit  
BUCKET: 00~FF  
CBS: 0000~FFFF  
EBS: 0000~FFFF  
ADVETH  
TRUNK  
PBVLAN  
TAGVLAN  
NEW / DEL / EDIT  
ETHBW: 64K~100M

DXC  
DEFAULT

DIAG: (Diagnosis Tools)  
APS:  
E□W / W□E  
ALS:  
Restart(2s) / Test(90s)  
LASER: (Laser test)  
OPT  
LPBK  
OPT  
Term / Line  
E1  
Term / Line  
V35  
Term / Line  
TRIB  
E1  
1 2 3 4  
BER/ERR/TIME  
View Result/ Run/Stop / Inject Error /Clean Result  
V35  
1 2 3 4  
BER/ERR/TIME  
View Result/ Run/Stop / Inject Error /Clean Result  
V.54  
V35  
Activation/Termination  
SYS: (System Settings)  
INFO  
F/W / H/W / EPLD / FPGA / S/N / MAC / UPTIME  
NET  
IP: (Set IP Address): {user keying}  
MASK: (Set IP Mask): {user keying}  
GATE: (Set Gateway): {user keying}  
TRAP  
TRAP1 / TRAP2 / TRAP3  
COMMUNITY  
SET / GET  
TIME  
{user keying}  
UPG  
TFTP  
Tftp server IP: xxx.xxx.xxx.xxx {user keying}  
Upgrade file: xxxx.tar.gz {user keying}  
MIRROR:  
L□R / R□L  
AUDI:  
Disable / Enable / Cut off

Synchronous:

Free-Run / Recovered

RST:

Disable / Enable / Cut off

NODE: (Node Settings)

{user keying}





[www.ctcu.com](http://www.ctcu.com)

T +886-2 2659-1021    F +886-2 2659-0237    E [info@ctcu.com](mailto:info@ctcu.com)



ISO 9001 Quality System Certified CTC Union Technologies Co.,LTD.

All trademarks are the property of their respective owners. Technical information in this document is subject to change without notice.