

# USER MANUAL

---

## ET100

*Synchronous WAN Ethernet Bridge*

*10/100Base-TX Ethernet over*

*V.35, X.21, RS-232/530/449*





***CTC Union Technologies Co., Ltd.***

NeiHu Hi- Tech Park

9F, No. 60 ZhouZi St.

NeiHu, Taipei, 114

Taiwan

ET100 Ethernet WAN Bridge, User Manual

Version 1.0 June 2003 Release

This manual supports the following models:

ET100 Ethernet WAN Bridge



# ***Table of Contents***

---

Overview and Features .....	1
Specifications .....	2
Functional Block Diagram .....	3
Unit Detail .....	4
Theory of Operation .....	7
DIP Switch Setting Tables .....	10
RS-232 I/F Pin Assignment .....	13
V.35 I/F Pin Assignment .....	14
RS-530/449 I/F Pin Assignment .....	15
X.21 I/F Pin Assignment .....	16
RS-530(232) Cable Pin Out .....	17
V.35 Cable Pin Out .....	18
RS-449 Cable Pin Out .....	19
X.21 Cable Pin Out .....	20
Sync Mode Clock Settings .....	21
Application Examples .....	22
Technical Inquiry Form .....	25

# ***Table of Contents***

---

This page left blank intentionally.

# ***ET100 LAN-WAN Bridge***

---

## **Overview**

The **ET100** Network Bridge is a high performance, remote, self-learning Ethernet bridge. Its compact size and low cost make it ideal for cost-sensitive bridging applications, or as a LAN extender or segmenter over bit stream type infrastructures. Several selectable data interfaces, including V.35, RS-530, RS-449, X.21, and RS-232, make this Ethernet Bridge's connection between 10Base-T and 100Base-TX LAN and various SYNC data port interfaces convenient.

## **Features**

- 10BASE-T/100BASE-TX, Full Duplex or Half Duplex
- HP Auto-MDI/MDIX detects and corrects crossed cable
- IEEE 802.3x flow control
- Real-time filtering with 256 address tables
- Automatic address learning, aging and deletion after 5 minutes
- Up to 340 packet-buffering capacity
- Forwarding and filtering rate at wire speed with through put latency of 1 frame.
- Auto padding of undersized packets to meet the minimum Ethernet packet size requirement
- Buffering modes can be selected according to the setting of WAN and LAN line speeds
- Ethernet interface has automatic Twisted Pair polarity correction
- Built-in nx64K / nx56K timing clock generator for WAN link
- Configurable WAN side Tx clock rising / falling clock edge operation

# ET100 LAN-WAN Bridge

---

## Specifications

### ■ LAN

Standard	Fully compliant with IEEE 802.3/802.3u
Connector	Shielded RJ-45
Speeds	10BASE-T/100BASE-TX, Full or Half Duplex
Frames	Supports 64 to 1522 byte packet lengths, standard and extended length frames for VLAN tagging, etc.

### ■ WAN

Interface	Selectable RS-232(SYNC), V.35, RS-449/530, and X.21
Protocol	Synchronous HDLC
Connector	DB25 Male
Type	DTE port
Data Rates	n x 64(56)Kbps, up to 2048Kbps
Clock Source	Tx/Rx internal or external

### ■ General

Power	AC Adapter; 100, 110, or 230VAC / 9VDC-1A Unit; DC9~12V/300mA
Environment	Temperature: 0~50° C Humidity: <90% non-condensing
Dimensions	135(L) x 80(W) x 25(H) mm
Weight	150g

### ■ LED INDICATORS

WAN Rx (yellow)	ON=WAN receive data
WAN Tx (yellow)	ON=WAN transmit data
Link (green)	ON=LAN link
LAN Rx (yellow)	ON=LAN receive data
LAN Tx (yellow)	ON=LAN transmit data
PWR (green)	ON=Power On
Error (red)	ON=LAN error
Full (yellow)	ON=Full Duplex
100M (yellow)	ON=100BASE-TX

# ET100 LAN-WAN Bridge

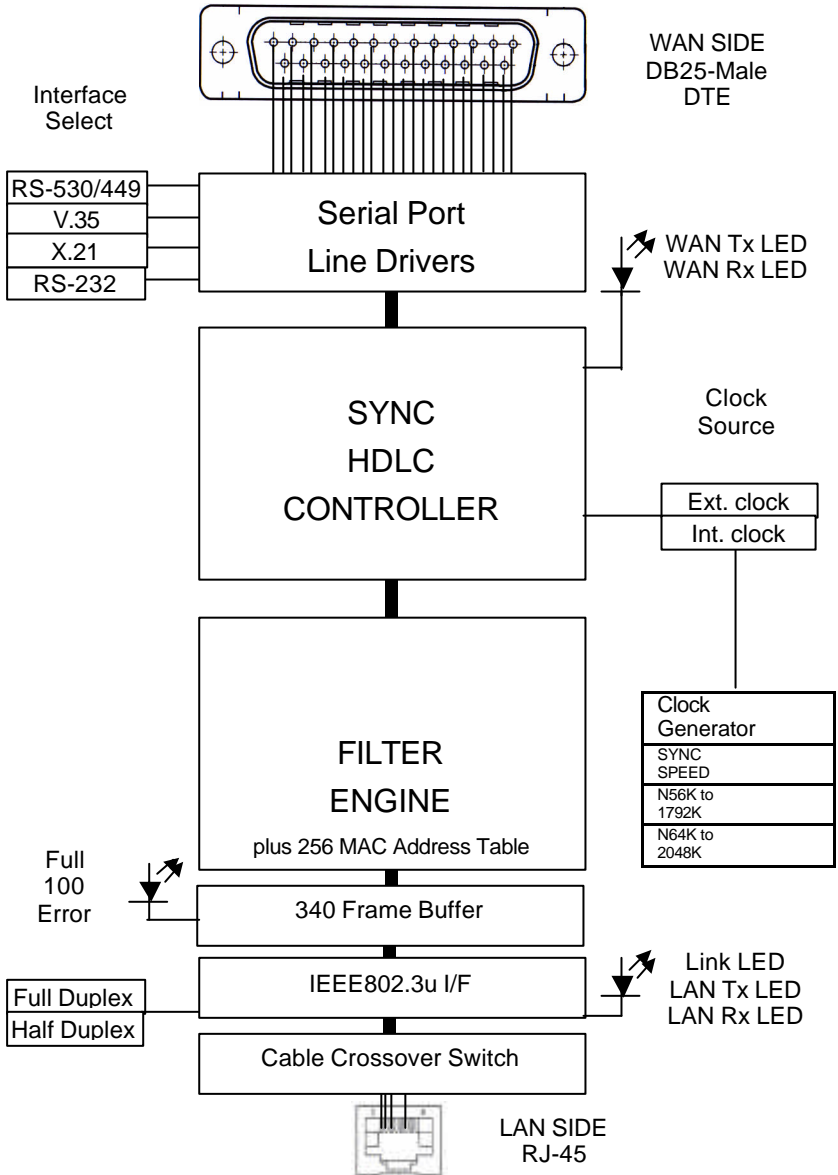

**Figure 1: ET100 Functional Block Diagram**

# ET100 LAN-WAN Bridge

## Unit Detail

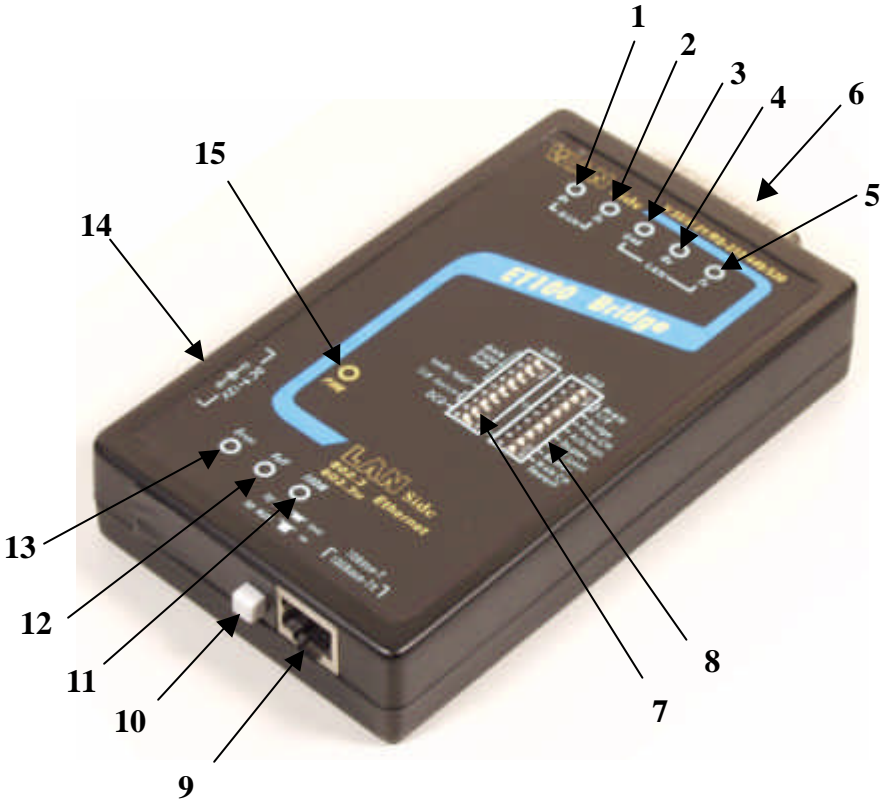

Figure 2. ET100 Unit Detail

## ***ET100 LAN-WAN Bridge***

---

- (1) WAN Rx LED:  
Yellow, on or flashing indicates receiving data on the WAN interface.
- (2) WAN Tx LED:  
Yellow, on or flashing indicates transmitting data on the WAN interface.
- (3) LAN Link LED:  
Green, indicates the Ethernet has a link to an external device.
- (4) LAN Rx LED:  
Yellow, flashes to indicate reception from the LAN.
- (5) LAN Tx LED:  
Yellow, flashes to indicate transmission to the LAN.
- (6) DB25 Male Connector:  
This connector connects to the appropriate adapter cable for connection to the various supported data interfaces. The **ET100** performs in DTE mode and its WAN port connector may be connected to a DCE device (such as a modem).
- (7) SW1:  
Configuration setting for the bridge. (Please refer to DIP SW setting table.) Connection to the Ethernet LAN is made here.
- (8) SW2:  
Configuration setting for the bridge. (Please refer to DIP SW setting table.) Connection to the Ethernet LAN is made here.
- (9) RJ-45 Ethernet LAN Port:  
This is an auto-MDI/MDIX port for connection to the LAN.

## ***ET100 LAN-WAN Bridge***

---

(10) LAN Cable Cross Over Switch:

When this pushbutton switch is pressed, the LAN port of the **ET100** can connect to a PC directly; when released, the LAN port of **ET100** can connect to a HUB directly (using a 1:1 UTP cable). This feature is useful in the event a device cannot get a link using the auto MDI/MDIX function.

(11) 100M LED:

Yellow on, indicates the LAN connection is 100Base-TX Ethernet. Off indicates 10Base-T Ethernet.

(12) Full LED:

Yellow on, lights to indicate a Full Duplex Ethernet connection. Off indicates half duplex Ethernet operation.

(13) Error LED:

Red on, indicates an error has occurred in **ET100**, for instance a buffer overrun or underrun.

(14) DC 9~12V

This jack receives power from the external DC 9~12V AC power adapter.

(15) PWR LED

Green on, when external power adapter is plugged in and AC power is supplied to it.

# ***ET100 LAN-WAN Bridge***

---

## **Theory of Operation**

A bridge is used to connect networks locally or remotely such that they appear to the user to be the same network. An Ethernet LAN bridge will connect two LAN segments at the Data Link Layer (ISO Layer 2). At this layer, the MAC (Media Access Control) addresses, are used for low level addressing to send information to devices. The bridge builds tables of MAC addresses for each network segment based on the source and destination addresses of the packets it receives and forwards, then filters the traffic not destined for the remote network.

The Ethernet-WAN bridge will connect two remote Ethernet networks over bit stream interfaces such as that of modems or DSU/CSUs. One method to do this is to use HDLC, an international standard set by the ISO, a set of protocols for carrying data over a link with error and flow control.

The **ET100** utilizes both Ethernet Bridging and HDLC encapsulation to provide a connection between LANs over bit stream architectures. The LAN side of the **ET100** receives an Ethernet packet and examines its destination MAC address. If it knows the MAC is on the local network then it simply drops the packet. Otherwise, if it knows the packet destination is on the remote side, or if it cannot be determined because its MAC cannot be found in the table, then it forwards it. During forwarding, the packet is processed for transmission across the WAN link. Here is where the Ethernet packet is encapsulated in HDLC.

# ET100 LAN-WAN Bridge

When the HDLC packet is received on the remote side unit's data port, The packet is checked for transmission errors, then the original Ethernet packet(s) is recovered and sent out the remote's LAN port completing the transmission. Here is the typical application of the **ET100**.



Typical application of ET100 LAN-WAN Bridge.

Many times the **ET100** is commonly referred to as an Ethernet to V.35, Ethernet to X.21, or Ethernet to Datacom 'converter'. As a sales/marketing term or non-technical reference, the term is OK. However, from a technical standpoint, the term is a misnomer. The Ethernet is not "converted" to V.35, it is run "over" the V.35 link. Conversion also implies that the interface can work both ways. This is NOT the case for the LAN-WAN Bridge as the following application shows.

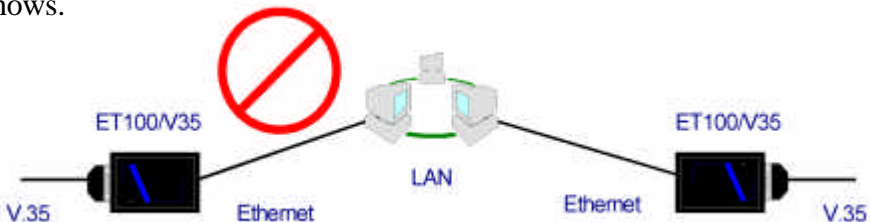

Application NOT ALLOWED for ET100.

## ***ET100 LAN-WAN Bridge***

---

Why does the previous application not work? Because, the application requires a bit stream to be encapsulated into Ethernet packets, or into TCP/IP and then Ethernet, for transmission across the LAN. This requires more than just manipulation at the Data Link layer (ISO Layer 2), it requires programming to include all seven layers including the Application layer. Transmitting bit stream or TDM (time division multiplexed) data over Ethernet requires a device such as an IP-MUX.

Please refer to the "Applications" section at the end of this manual for additional application examples.

# ET100 LAN-WAN Bridge

## DIP Switch Setting Tables:

When the **ET100** is set to internal WAN clock, SW1-1 to SW1-6 configure the data rate. If WAN Tclk and Rckl are external, don't care.

DATA RATE						
SW1-1	SW1-2	SW1-3	SW1-4	SW1-5	SW1-6 ON	SW1-6 OFF
OFF	OFF	OFF	OFF	OFF	56K(1*56K)	64K(1*64K)
ON	OFF	OFF	OFF	OFF	112K(2*56K)	128K(2*64K)
OFF	ON	OFF	OFF	OFF	168K(3*56K)	192K(3*64K)
ON	ON	OFF	OFF	OFF	224K(4*56K)	256K(4*64K)
OFF	OFF	ON	OFF	OFF	280K(5*56K)	320K(5*64K)
ON	OFF	ON	OFF	OFF	336K(6*56K)	384K(6*64K)
OFF	ON	ON	OFF	OFF	392K(7*56K)	448K(7*64K)
ON	ON	ON	OFF	OFF	448K(8*56K)	512K(8*64K)
OFF	OFF	OFF	ON	OFF	504K(9*56K)	576K(9*64K)
ON	OFF	OFF	ON	OFF	560K(10*56K)	640K(10*64K)
OFF	ON	OFF	ON	OFF	616K(11*56K)	704K(11*64K)
ON	ON	OFF	ON	OFF	672K(12*56K)	768K(12*64K)
OFF	OFF	ON	ON	OFF	728K(13*56K)	832K(13*64K)
ON	OFF	ON	ON	OFF	784K(14*56K)	896K(14*64K)
OFF	ON	ON	ON	OFF	840K(15*56K)	960K(15*64K)
ON	ON	ON	ON	OFF	896K(16*56K)	1024K(16*64K)
OFF	OFF	OFF	OFF	ON	952K(17*56K)	1088K(17*64K)
ON	OFF	OFF	OFF	ON	1008K(18*56K)	1152K(18*64K)
OFF	ON	OFF	OFF	ON	1064K(19*56K)	1216K(19*64K)
ON	ON	OFF	OFF	ON	1120K(20*56K)	1280K(20*64K)
OFF	OFF	ON	OFF	ON	1176K(21*56K)	1344K(21*64K)
ON	OFF	ON	OFF	ON	1232K(22*56K)	1408K(22*64K)
OFF	ON	ON	OFF	ON	1288K(23*56K)	1472K(23*64K)
ON	ON	ON	OFF	ON	1344K(24*56K)	1536K(24*64K)
OFF	OFF	OFF	ON	ON	1400K(25*56K)	1600K(25*64K)
ON	OFF	OFF	ON	ON	1456K(26*56K)	1664K(26*64K)
OFF	ON	OFF	ON	ON	1512K(27*56K)	1728K(27*64K)
ON	ON	OFF	ON	ON	1544K	1792K(28*64K)
OFF	OFF	ON	ON	ON	1544K	1856K(29*64K)
ON	OFF	ON	ON	ON	1544K	1920K(30*64K)
OFF	ON	ON	ON	ON	1544K	1984K(31*64K)
ON	ON	ON	ON	ON	1544K	2048K(32*64K)

**Table 1: DIP settings for Data Rate.**

# ET100 LAN-WAN Bridge

DIP SW1	STATE	FUNCTION	REMARK
-7	OFF	WAN TCLK: External	
	ON	WAN TCLK: Internal	
-8	OFF	WAN RCLK: External	
	ON	WAN RCLK: Internal	

**Table 2: DIP settings for clock source.**

DIP SW1	STATE	FUNCTION	REMARK
-9	OFF	WAN Port is always in sync	
	ON	WAN Port is sync if DCD active	

**Table 3: WAN Port SYNC Status**

WAN INTERFACE		
SW2-1	SW2-2	TYPE
OFF	OFF	RS-449/RS-530
ON	OFF	X.21
OFF	ON	V.35
ON	ON	RS-232

**Table 4: WAN interface type settings.**

DIP SW2	STATE	FUNCTION	REMARK
-3	OFF	Filter Enable (Bridge mode)	
	ON	Filter Disable (transparent forwarding)	
-4	OFF	Disable 802.3x flow control	
	ON	Enable 802.3x flow control	
-5	OFF	LAN auto-negotiation is enabled	ignore 6,7
	ON	LAN auto-negotiation is disabled	
-6	OFF	Ethernet Full Duplex	
	ON	Ethernet Half Duplex	
-7	OFF	100Base-TX Ethernet speed	
	ON	10Base-T Ethernet speed	
-8	OFF	LAN to WAN = WAN to LAN (1:1)	(pkt. buffer)
	ON	LAN to WAN > WAN to LAN (9:1)	
-9	OFF	WAN Tx clock polarity normal	
	ON	WAN Tx clock polarity inverted	

**Table 5: Miscellaneous settings**

## ***ET100 LAN-WAN Bridge***

---

When the **ET100** leaves the factory, all DIP switch settings are set to the OFF position.

### **Filter:**

When this feature is disabled, all frames are passed transparently. In this configuration, the **ET100** acts as a repeater. When the filter is enabled, frame destinations are tested against the internal MAC address table. Filtering enabled is the normal selection for Bridging.

### **Auto-negotiation:**

When this feature is enabled (SW2-5=OFF), the Duplex (SW2-6) and Speed (SW2-7) settings are ignored and are automatically determined from the LAN connection. When this feature is disabled, the Duplex and Speed settings of the LAN follow the settings of SW2-6 and SW2-7.

### **Packet Buffer Utilization:**

The **ET100** contains a 340 packet buffering capacity. When SW2-8 is OFF, this buffer is divided equally between LAN to WAN and WAN to LAN packet traffic. When the LAN is Fast Ethernet and the WAN connection is slow, the buffer may be better utilized by applying a greater portion to the LAN to WAN packet traffic. In this case, set SW2-8 to ON. This will provide a 9 to 1 buffer division for LAN to WAN versus WAN to LAN buffer and should increase utilization.

# ET100 LAN-WAN Bridge

## WAN Port Pin Assignment

*The following tables give the pin, circuit, function and signal direction as seen on the ET100's DB25M connector for each of the selectable interfaces. RS-232 and RS-530 connections may be made directly. Adapter cables are required to match the physical connectors for V.35 (MB34), X.21 (DB15) and RS-449 (DB37).*

### *a. V.24/RS-232 INTERFACE PIN ASSIGNMENT*

<b>PIN</b>	<b>CIRCUIT</b>	<b>FUNCTION</b>	<b>DIRECTION</b>	<b>EIA</b>
1	FGND	Protective GND		AA
2	TD	Transmit data	OUT	BA
3	RD	Receive data	IN	BB
4	RTS	Request to send	OUT	CA
5	CTS	Clear to send	IN	CB
6	DSR	Data set ready	IN	CC
7	GND	Signal ground		AB
8	DCD	Carrier detect	IN	CF
15	TC	Transmit clock	IN	DB
17	RC	Receive clock	IN	DD
20	DTR	Data term ready	OUT	CD
24	XTC	DTE xmit clock	OUT	DA

**Table 7: RS-232 Interface Pin Assignment**

**SW2-1/2-2 ON/ON**

# ET100 LAN-WAN Bridge

---

## *b. V.35 INTERFACE PIN ASSIGNMENT*

<b>PIN</b>	<b>CIRCUIT</b>	<b>FUNCTION</b>	<b>DIRECTION</b>	<b>CCITT</b>
1	FGND	Protective GND		101
2	TD(A)	Xmit data A	OUT	103
3	RD(A)	Receive data A	IN	104
4	RTS	Request to send	OUT	105
5	CTS	Clear to send	IN	106
6	DSR	Data set ready	IN	107
7	GND	Signal ground		102
8	DCD	Data carrier detect	IN	109
9	RC(B)	Receive clock B	IN	115
11	XTC(B)	DTE Xmit clock B	OUT	113
12	TC(B)	Xmit clock B	IN	114
14	TD(B)	Xmit data B	OUT	103
15	TC(A)	Xmit clock A	IN	114
16	RD(B)	Receive data B	IN	104
17	RC(A)	Receive clock A	IN	115
20	DTR	Data terminal ready	OUT	108
24	XTC(A)	DTE Xmit clock A	OUT	113

**Table 8: V.35 Interface Pin Assignment**

**SW2-1/2-2 OFF/ON**

## **ET100 LAN-WAN Bridge**

### ***c. RS-449/RS-530 INTERFACE PIN ASSIGNMENT***

<b>PIN</b>	<b>CIRCUIT</b>	<b>FUNCTION</b>	<b>DIRECTION</b>	<b>CCITT</b>
1	FGND	Protective GND		101
2	SD(A)	Xmit data A	OUT	103
3	RD(A)	Receive data A	IN	104
4	RS(A)	Request to send A	OUT	105
5	CS(A)	Clear to send A	IN	106
6	DM(A)	Data set ready A	IN	107
7	GND	Signal ground		102
8	RR(A)	Data carrier detect A	IN	109
9	RT(B)	Receive clock B	IN	115
10	RR(B)	Data carrier detect B	IN	109
11	TT(B)	DTE Xmit clock B	OUT	113
12	ST(B)	Xmit clock B	IN	114
13	CS(B)	Clear to send B	IN	106
14	SD(B)	Xmit data B	OUT	103
15	ST(A)	Xmit clock A	IN	114
16	RD(B)	Receive data B	IN	104
17	RT(A)	Receive clock A	IN	115
19	RS(B)	Request to send B	OUT	105
20	TR(A)	Data terminal ready A	OUT	108
22	DM(B)	Data set ready B	IN	107
23	TR(B)	Data terminal ready B	OUT	108
24	TT(A)	DTE Xmit clock A	OUT	113

**Table 9: RS-449/RS-530 INTERFACE PIN ASSIGNMENT**

**SW2-1/2-2 OFF/OFF**

# **ET100 LAN-WAN Bridge**

---

## ***d. X.21 INTERFACE PIN ASSIGNMENT***

<b>PIN</b>	<b>CIRCUIT</b>	<b>FUNCTION</b>	<b>DIRECTION</b>	<b>CCITT</b>
1	FGND	Protective GND		101
2	T(A)	Xmit data A	OUT	103
3	R(A)	Receive data A	IN	104
4	C(A)	Request to send A	OUT	105
7	GND	Signal ground		102
8	I(A)	Data carrier detect A	IN	109
9	S(B)	Receive clock B	IN	115
10	I(B)	Data carrier detect B	IN	109
14	T(B)	Xmit data B	OUT	103
16	R(B)	Receive data B	IN	104
17	S(A)	Receive clock A	IN	115
19	C(B)	Request to send B	OUT	105

**Table 10: X.21 INTERFACE PIN ASSIGNMENT**

**SW2-1/2-2 ON/OFF**

# ET100 LAN-WAN Bridge

---

## Cable Pin Assignments:

*RS-530 Cable, 25 conductor round, 1 to 1, 1m.*

(Use this cable for RS-232 applications as well.)

Part#:58-D2FD2M007, RS-530 Cable, DB25 Female <=> DB25 Male, 1 Meter

Part#:58-D2FD2F010, RS-530 Cable, DB25 Female <=> DB25 Female, 1 Meter

DB25(Female)		DB25(Male/Female)
PIN		PIN
1	<=====>	1
2	<=====>	2
3	<=====>	3
4	<=====>	4
5	<=====>	5
6	<=====>	6
7	<=====>	7
8	<=====>	8
9	<=====>	9
10	<=====>	10
11	<=====>	11
12	<=====>	12
13	<=====>	13
14	<=====>	14
15	<=====>	15
16	<=====>	16
17	<=====>	17
18	<=====>	18
19	<=====>	19
20	<=====>	20
21	<=====>	21
22	<=====>	22
23	<=====>	23
24	<=====>	24
25	<=====>	25

# ET100 LAN-WAN Bridge

---

## V.35 Cable, multi-conductor round, 1m.

Part#:58-D2FM3M001, V.35 Cable, DB25 Female – MB34 Male, 1 Meter

Part#:58-D2FM3F000, V.35 Cable, DB25 Female – MB34 Female, 1 Meter

DB25(Female)		MB34(Male/Female)
PIN		PIN
2	<=====>	P
14	<=====>	S
3	<=====>	R
16	<=====>	T
4	<=====>	C
5	<=====>	D
6	<=====>	E
20	<=====>	H
8	<=====>	F
24	<=====>	U
11	<=====>	W
15	<=====>	Y
12	<=====>	AA
17	<=====>	V
9	<=====>	X
1	<=====>	A
7	<=====>	B
22	<=====>	J

NOTE: TWISTED PAIRS;

P,S

R,T

U,W

Y,AA

V,X

# ET100 LAN-WAN Bridge

---

## ***RS-449 Cables, multi-conductor round, 1m.***

Part#:58-D2FD3M003, RS-449 Cable, DB25 Female – DB37 Male, 1M

Part#:58-D2FD3F000, RS-449 Cable, DB25 Female – DB37 Female, 1M

DB25(Female)		DB37(Male/Female)
PIN		PIN
1	<=====>	1
7	<=====>	19
(the following are all twisted pairs)		
2	<=====>	4
14	<=====>	22
3	<=====>	6
16	<=====>	24
4	<=====>	7
19	<=====>	25
5	<=====>	9
13	<=====>	27
6	<=====>	11
22	<=====>	29
20	<=====>	12
23	<=====>	30
8	<=====>	13
10	<=====>	31
24	<=====>	17
11	<=====>	35
15	<=====>	5
12	<=====>	23
17	<=====>	8
9	<=====>	26

# ET100 LAN-WAN Bridge

---

## X.21 Cables, multi-conductor round, 1m.

Part#:58-D1MD2F003, X.21 Cable, DB25 Female – DB15 Male, 1M

Part#:58-D1FD2F001, X.21 Cable, DB25 Female – DB15 Female, 1M

DB25(Female)		DB15(Male/Female)
PIN		PIN
1	<=====>	1
7	<=====>	8
(the following are all twisted pairs)		
2	<=====>	2
14	<=====>	9
3	<=====>	4
16	<=====>	11
4	<=====>	3
19	<=====>	10
8	<=====>	5
10	<=====>	12
17	<=====>	6
9	<=====>	13

# ET100 LAN-WAN Bridge

---

## Sync Mode Clock Settings

Interface	RS-530/449/232 or V.35		X.21	
Signals	TD(103)	RD(104)	TD(103)	RD(104)
WAN TCLK External	From TC(114)		From RC(115),S	
WAN TCLK Internal	Internal		(Internal)*	
WAN RCLK External		From RC(115)		From RC(115),S
WAN RCLK Internal		Internal		(Internal)*

**Table 11: SYNC Mode Clock Settings**

\* Because the **ET100**'s WAN port is DTE, the X.21 clock sources for transmit and receive are always issued from the DCE side S signal. Setting the **ET100**'s X.21 clock mode to internal is not recommended.

# ET100 LAN-WAN Bridge

---

## APPLICATIONS

In the following example, the **ET100** is configured for bridging over an E1 (or T1) carrier provider's network. The **ET100's** interface is set to V.35 to match the CSU/DSU unit. The CSU/DSU may be set unframed or may be set to use a fraction ( $n \times 56$  or  $n \times 64$ ) of the E1 (or T1) line. The CSU/DSU timing is received from the carrier provider's network so the **ET100's** timings for Tx and Rx clocks should both be set to external. In this configuration, the rate DIP settings of the **ET100** are ignored.



**Figure 3: Bridging over E1 services**

# ET100 LAN-WAN Bridge

---

## APPLICATIONS

In the next example, the **ET100** is setup to bridge over a PSTN's leased line. The **ET100s** speed settings depend upon the speed of the leased line and the settings of the modems. The timing scheme recommended is this application is for the Tx and Rx Clocks of each unit to be set to External while the clocks of the modems are set to Internal for both or Internal for one and Loop for the other.

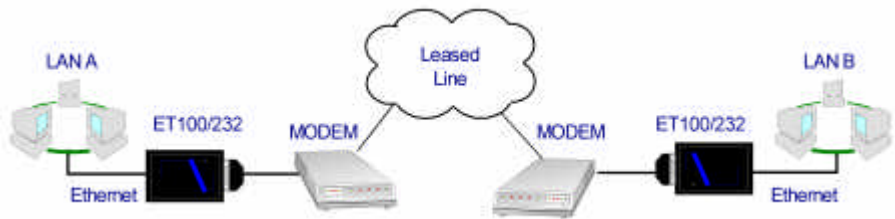

**Figure 4: Bridging over Synchronous leased line.**

# ET100 LAN-WAN Bridge

---

## APPLICATIONS

In the following example, the **ET100** is paired with a G703/64K interface converter to provide connection over G.703 64Kbps services. If the G.703 transmit and receive clocks are provided by the central carrier, each G703/64K converter will be set to centradirectional line timing. Both **ET100**'s will have their Tx / Rx clocks set external.



**Figure 6: ET100 bridge over G.703 64K services.**

# CTC Union Technologies Inc

Fax:(886)2 27991355

Tel:(886)2 26591021

E-mail:support@ctcu.com

Attn : Technical Support Department

From Company: \_\_\_\_\_

Name: \_\_\_\_\_

Tel: (    ) \_\_\_\_\_

Fax:(    ) \_\_\_\_\_

■ MODEL:     ET100

■ ACTIVITY: As attached in DIP switch setting table

■ SYS CONFIGURATION:

■ Question



### Technical Inquiry Form

**MODEL No.:**     **ET100**

Please fill in the DIP switches configuration with ' ' marks into the following table.

Send it to us by fax, and we will reply to you immediately.

SW NO.	DIP	FUNCTION	Your Setting		CTC Suggestion	
			ON	OFF	ON	OFF
SW1	1	WAN Clock Rate (Internal)				
	2	WAN Clock Rate (Internal)				
	3	WAN Clock Rate (Internal)				
	4	WAN Clock Rate (Internal)				
	5	WAN Clock Rate (Internal)				
	6	Clock multiplier (n56/64)				
	7	WAN Tx Clock source				
	8	WAN Rx Clock source				
	9	WAN Sync Status				
SW2	1	WAN I/F Type				
	2	WAN I/F Type				
	3	Bridge / Repeater				
	4	802.3x Flow Control				
	5	auto negotiation / manual				
	6	Full / Half Duplex manual				
	7	10 / 100Base manual				
	8	Packet Buffer setting				
	9	Tx Clock Polarity				

Additional comments/questions:





***CTC Union Technologies Co., Ltd.***

Nei-Hu HI-TECH Park  
9F, No. 60 ZhouZi Street,  
Nei-Hu, Taipei, Taiwan

Phone:(886) 2.2659.1021 Fax:(886) 2.2799.1355  
E-mail: [info@ctcu.com](mailto:info@ctcu.com) <http://www.ctcu.com>