

FOM Family

E1/T1/Datacom/Ethernet Fiber Optical Multiplexer



FMUX01A

The FMUX01A is a 1U, 19" rack mountable, E1/T1, serial data communications & Ethernet bridge multiplexer that transmits up to 16 channels over a single fiber optic link. The FMUX01A features a modular design that provides a wide variety of customized user configurations. The hot swappable optical fiber interface modules are available in single mode or multi-mode fiber connections and a number of connector types. The FMUX01A chassis is available in five different power configurations: single AC, single DC, dual AC, dual DC or AC+DC. The AC supplies operate from 90~260VAC while DC supplies operate from 36~72VDC or 20~60VDC. From the rear of the chassis, one to four quad E1 or T1 line cards, datacom (V.35, X.21, RS-530), or Ethernet Bridge cards are supported. All line cards provide completely transparent transmission of E1, T1, datacom, or Ethernet regardless of frame mode or timeslot assignment. Optional hardware cards are also available for external clock and SNMP. The standard FMUX01A configuration may be viewed or set via the front panel LCD/menu keys, serial VT-100 terminal connection or Telnet/SNMP with SNMP option.

Features

- 1U, 19 (23)" 4 slot chassis
- Alarm relay contacts provided which can offer major and minor alarms with audible and visible alarm output
- Auto Laser Shutdown (ALS) to prevent hazardous laser radiation to personnel
- Channel Capacity : 4,8,12 or 16 channels
- Configuration data is automatically stored into flash to avoid any loss caused by power disruption.
- End to end propagation delay < 2μsec
- Management : Local side is managed via Keypad or Terminal.
- Remote side is managed in-band via keypad or Terminal.
- Telnet & SNMP local/remote management with optional SNMP
- Real Time Clock (RTC) run by backup battery to avoid time setting loss caused by power disruption
- Redundant Fiber 1+1 Protection, the switching time is less than 50 m sec
- Supports embedded optical BERT
- Supports fiber, E1/ T1/ datacom Local and Remote Loop-Back.
- Supports hot-swapping of a optical module
- TFTP upgradeable (for SNMP option)

Specifications

Ports	Connector : 1x9 (SC, ST, FC)
Optical Interface :	Data rate : 51.84Mbps
	Bit Error Rate : Less than 10 ⁻¹¹
Cable type :	MM 62.2/125μm, 50/125μm.
	SM 9/125μm
Distance :	MM 2km. SM 15/30/50/80/120km,
	WDM 20/40/60/80km
Wavelength :	1310, 1550nm
Electrical Interface :	Console, SNMP, EXT CLK : RJ45
Alarm :	RS232 (DB9F)
Standard	E1:ITU-T, T1:ITU-T, AT&T, ANSI, Ethernet: IEEE802.3x
LEDs	PWR, Alarm, Far End /Near End Error, System failure, E1/T1 status
Power	AC : 100 ~240V
	DC24 : 20 ~ 60V, DC48 : 36 ~ 72V
Power Consumption	< 40W
Dimensions (D x W x H)mm	250 x 438 x 43mm
Weight	3.58 kg
Temperature	0~50°C (Operating) ,0~70°C (Storage)
Humidity	10~90% non-condensing
Certification	CE, FCC, RoHS
MTBF	57350 hours

Application

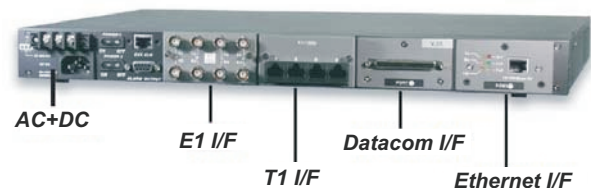
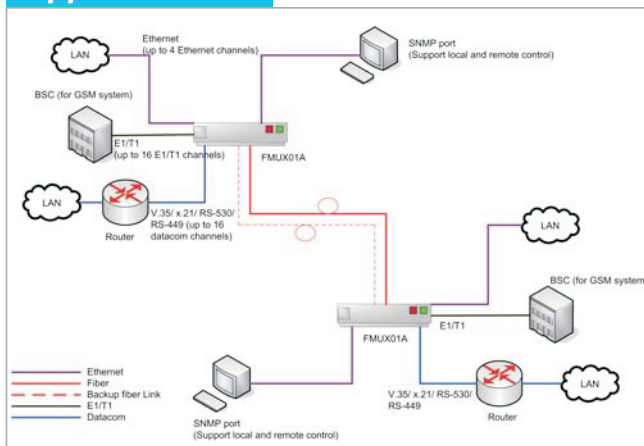

Interface Modules



E1/T1 RJ - 45 I/F



E1 BNC I/F



E1/T1 Wire-Wrap I/F



Ethernet I/F



Datacom I/F

Fiber Optical Module	
Ports	1 + 1 ports (redundant)
Fiber Cable	9/ 125 um for single mode ; 50/ 125 or 62.5/ 125 for multi-mode
System Power Gain	> 25dB@1*10 ⁻¹⁰
Wavelength Range	1280 — 1550nm
Connector	FC/PC

The switching time between is less than 50m sec

E1 Interface Module	
Standards	ITU-T G.703, G.704, G.706, G.732
Ports	4 ports
Framing	Unframed (clear channel)
Data rate	2.048 Mbps ±50 ppm
Line code	HDB3/AMI
Receive Level	Short haul - 15dB
Line impedance	75 ohms ±5% / 120 ohms ±5%
Connector	RJ-45 for 120 ohms BNC for 75 ohms Wirewrap for 120 ohms

T1 Interface Module	
Standards	ITU-T G.703, G.704, AT&T TR-62411, ANSI T1.403
Ports	4 ports
Framing	Unframed (clear channel)
Data rate	1.544 Mbps ±50 ppm
Line code	B8ZS / AMI
Receive Level	Short haul - 15dB
Line impedance	100 ohms ±5%
Connector	RJ-45 Wirewrap

Ethernet Interface Module	
Standard	IEEE 802.3 / 802.3u
Ports	1 port
Data rate	10/100Mbps; Half Duplex 20/200Mbps; Full duplex
Filtering and Forwarding	60000 frames per second
Delay	1 frame
WAN Protocol	Raw HDLC
Connector	Shielded RJ-45

Datacom Interface Module	
Standard	N/A
Card Type	V.35/ RS-530 (Include X.21 and RS-449)/ RS-232 I/F
Bit rate	n x 64K, n = 1 to 32 V.35 & RS-530 up to 2Mbps RS-232 up to 128Kbps (SYNC)
Line code	NRZ
Clock Mode	Transparent, Recovery External (From data port) Internal (From oscillator)
Control Signal	CTS always On or follows RTS DSR constantly ON, except during test loops (RS-530 DSR always connect to DTR) DCD constantly ON, except during fiber signal loss
Test Loops	Local loop back, Remote loop back, V.54
Connector	Type Uses HD-68 pin D type Female with adapter cables

NEW !!

High-speed Datacom Interface Module	
Standard	N/A
Card Type	V.35/ RS-530
Bit rate	n x 64K/ n x 256K, n = 1 to 32 V.35 & RS-530 up to 8Mbps
Line code	NRZ
Clock Mode	Transparent, Recovery External (From data port) Internal (From oscillator)
Control Signal	CTS always On or follows RTS DSR constantly ON, except during test loops (RS-530 DSR always connect to DTR) DCD constantly ON, except during fiber signal loss
Test Loops	Local loop back, Remote loop back, V.54
Connector	Type Uses HD-68 pin D type Female with adapter cables



Ordering Info - Modules

For Individual Purchase of Extra Modules		
E1/T1 Interface Card	FMUX01A-E1/BNC	4 x G.703 E1 BNC
	FMUX01A-E1/RJ45	4 x G.703 E1 RJ-45
	FMUX01A-T1RJ45	4 x G.703 T1 RJ-45
	FMUX01A-E1/ Wire-Wrap	4 x G.703 wire-wrap
Ethernet Interface Card	FMUX01A-Ethernet	1 x 10/100 Mbps Ethernet Bridge
External Clock	FMUX01A-EXT/CLK	External clock
SNMP	FMUX01A-SNMP	support console RS-232 port and 10/100Base-T Ethernet port, with SNMP MIB file
GUI	FMUX01A-GUI	GUI, support WIN 95, 98, 2000, XP
EMS	FMUX01A-EMS	EMS, server-client architecture with MS-SQL database

Optical Transceiver Interface		
FMUX01-A-X/	XX	XXX
Fiber Redundant	Connector Type	Distance Connectivity
S: standard	SC	002: 2km
R: redundant	ST	030: 30km
	FC	050: 50km
	LC	080: 80km
	MT	120: 120km
		20A: 20km
		20B: 20km
		40A: 40km
		40B: 40km
		60A: 60km
		60B: 60km