

User Manual



SHDTU03b NTU Series

G.SHDSL.bis TDM NTU



CTC UNION TECHNOLOGIES CO., LTD.

CTC Union Technologies Co., Ltd.

Far Eastern Vienna Technology Center (Neihu Technology Park)

8F, No. 60 Zhouzi St.

Neihu District

Taipei 114

Taiwan

Tel: +886-2-26591021

Fax: +886-2-27991355

Email: info@ctcu.com

URL: <http://www.ctcu.com>

SHDTU03b NTU Series User Manual

This manual supports the entire G.SHDSL.bis TDM family of modems

SHDTU03b-E1 NTU

SHDTU03b-Data (V.35,X.21,RS530/449) NTU

SHDTU03b-ET100 (Ethernet bridge, TDM) NTU

SHDTU03b-31 (3-in-1 E1, Data, Ethernet) NTU

SHDTU03b-31T (4-in-1 E1/T1, Data, Ethernet) NTU

Version 0.9a (draft)

Version 1.0 March 2010 (Release)

Copyright © 2008~2010, CTC Union Technologies, Inc.

All rights reserved.



All specifications are subject to change without prior notice.

Legal

The information in this publication has been carefully checked and is believed to be entirely accurate at the time of publication. CTC Union Technologies assumes no responsibility, however, for possible errors or omissions, or for any consequences resulting from the use of the information contained herein. CTC Union Technologies reserves the right to make changes in its products or product specifications with the intent to improve function or design at any time and without notice and is not required to update this documentation to reflect such changes.

CTC Union Technologies makes no warranty, representation, or guarantee regarding the suitability of its products for any particular purpose, nor does CTC Union assume any liability arising out of the application or use of any product and specifically disclaims any and all liability, including without limitation any consequential or incidental damages.

CTC Union products are not designed, intended, or authorized for use in systems or applications intended to support or sustain life, or for any other application in which the failure of the product could create a situation where personal injury or death may occur. Should the Buyer purchase or use a CTC Union product for any such unintended or unauthorized application, the Buyer shall indemnify and hold CTC Union Technologies and its officers, employees, subsidiaries, affiliates, and distributors harmless against all claims, costs, damages, expenses, and reasonable attorney fees arising out of, either directly or indirectly, any claim of personal injury or death that may be associated with such unintended or unauthorized use, even if such claim alleges that CTC Union Technologies was negligent regarding the design or manufacture of said product.

TRADEMARKS

Microsoft is a registered trademark of Microsoft Corp.

HyperTerminal™ is a registered trademark of Hilgraeve Inc.

WARNING:

This equipment has been tested and found to comply with the limits for a Class A digital device, pursuant to Part 15 of the FCC Rules. These limits are designed to provide reasonable protection against harmful interference when the equipment is operated in a commercial environment. This equipment generates, uses, and can radiate radio frequency energy and if not installed and used in accordance with the instruction manual may cause harmful interference in which case the user will be required to correct the interference at his own expense. NOTICE: (1) The changes or modifications not expressly approved by the party responsible for compliance could void the user's authority to operate the equipment. (2) Shielded interface cables and AC power cord, if any, must be used in order to comply with the emission limits.

CISPR PUB.22 Class A COMPLIANCE:

This device complies with EMC directive of the European Community and meets or exceeds the following technical standard. EN 55022 - Limits and Methods of Measurement of Radio Interference Characteristics of Information Technology Equipment. This device complies with CISPR Class A.

CE NOTICE

Marking by the symbol CE indicates compliance of this equipment to the EMC and LVD directives of the European Community. Such marking is indicative that this equipment meets or exceeds the following technical standards: EN 55022:2006, Class A, EN55024:1998+A1:2001+A2:2003, and EN60950-1:2001

Tables of Contents

1. INTRODUCTION	9
1.1 FEATURES.....	10
1.2 SPECIFICATION	10
1.3 APPLICATIONS	11
2. GETTING TO KNOW THE SHDSL.BIS NTU	12
2.1 FRONT PANEL.....	12
2.1.1. E1 interface model.....	12
2.1.2. Serial interface model.....	12
2.1.3. Ethernet interface model.....	13
2.1.4. Multi-interfaces model.....	13
2.2 REAR PANEL.....	15
2.2.1. E1/T1 Interface Model.....	15
2.2.2. Serial Interface Model.....	16
2.2.3. Ethernet Interface Model.....	17
2.2.4. Multi-interfaces in one Model.....	18
2.3 INSTALLATION	19
2.3.1. E1/T1 Interface.....	20
2.3.2. Serial Interface.....	21
2.3.3. Ethernet Interface.....	22
3. CONFIGURATION WITH KEYPAD AND LCD	24
3.1 KEYPAD.....	24
3.2 MAIN MENU TREE	25
3.3 MENU TREE FOR SHOW STATUS.....	27
3.4 MENU TREE FOR SHOW STATISTICS	29
3.4.1. Show Statistic on E1 Interface.....	31
3.4.2. Show Statistic on Serial/Ethernet/T1 Interface.....	32
3.5 MENU TREE FOR SYSTEM SETUP.....	33
3.5.1. Sub-Menu tree for SETUP SHDSL.....	34
3.5.2. Sub-Menu tree for SETUP E1 Interface.....	35
3.5.3. Sub-Menu tree for SETUP SERIAL Interface.....	39
3.5.4. Sub-menu tree for SETUP Ethernet Interface.....	42
3.5.5. Sub-menu tree for SETUP T1 Interface	43
3.5.6. Application of STU-R configuration follow STU-C.....	45
3.5.7. Application of Multi-interface.....	46
3.6 SUB-MENU TREE FOR REBOOT SYSTEM	61
3.7 SUB-MENU TREE FOR DIAGNOSTIC	62
3.7.1. Loopback function.....	62
3.7.2. BER Test function.....	65
4. PARAMETERS TABLE	66
4.1 SHDTU03B-E1	66
4.1.1. SHDTU03b-E1I -- E1 interface mode.....	66
4.1.2. SHDTU03b-E1/T1 -- T1 interface mode.....	66
4.2 SHDTU03B-DATA.....	67
4.2.1. SHDTU03b-Data -- Serial interface mode.....	67
4.3 SHDTU03B-ET100	68
4.3.1. SHDTU03b-ET100 -- Ethernet interface mode	68

4.4	SHDTU03B-31	69
4.4.1.	SHDTU03b-31 -- E1 Interface mode	69
4.4.2.	SHDTU03b-31 -- Serial Interface mode	70
4.4.3.	SHDTU03b-31 -- Ethernet Interface mode	71
4.4.4.	SHDTU03b-31 -- E1+Serial Interface mode	72
4.4.5.	SHDTU03b-31 -- E1+Ethernet Interface mode	73
4.5	SHDTU03B-E1/T1	74
4.5.1.	SHDTU03b-E1/T1 -- E1 Interface mode	74
4.5.2.	SHDTU03b-E1/T1 -- T1 Interface mode	75
4.6	SHDTU03B-31T	76
4.6.1.	SHDTU03b-31T -- E1 Interface mode	76
4.6.2.	SHDTU03b-31T -- T1 Interface mode	77
4.6.3.	SHDTU03b-31T -- Serial Interface mode	78
4.6.4.	SHDTU03b-31T -- Ethernet Interface mode	79
4.6.5.	SHDTU03b-31T -- E1+ Serial Interface mode	80
4.6.6.	SHDTU03b-31T -- E1 + Ethernet Interface mode	81
4.6.7.	SHDTU03b-31T -- T1+ Serial Interface mode	82
4.6.8.	SHDTU03b-31T -- T1 + Ethernet Interface mode	83
5.	CONFIGURATION WITH CONSOLE PORT	84
5.1	LOGIN PROCEDURE	85
5.2	WINDOW STRUCTURE	86
5.3	MAIN MENU SUMMARY	87
5.4	CONFIGURATION	88
5.4.1.	Configure NTU Interface	89
5.4.2.	Configure SHDSL parameters	91
5.4.3.	Configure E1 parameters	94
5.4.4.	Configure Serial parameters	102
5.4.5.	Configure Ethernet parameter	106
5.4.6.	Configure T1 parameter	109
5.4.7.	Remote configuration	113
5.4.8.	Restore factory default	114
5.5	REBOOT	117
5.6	VIEW THE SYSTEM STATUS	118
5.6.1.	View the SHDSL status	118
5.6.2.	View the Interface status	119
5.6.3.	View the Statistics	122
5.7	VIEW SYSTEM CONFIGURATION	127
5.7.1.	Show system Information	127
5.7.2.	Show system with listing format	129
5.7.3.	Show system with script format	131
5.8	UPGRADE	135
5.9	DIAGNOSTIC	139
5.10	EXIT	142

6.	APPENDIX	144
6.1	ABBREVIATIONS	144
6.2	SERIAL INTERFACE PIN ASSIGNMENTS	147
6.3	V.35 DB25(M) TO M.34(F) ADAPTOR CABLE	148
6.4	X.21 DB25(M) TO DB15(F) ADAPTOR CABLE	150
6.5	CONSOLE CABLE.....	152
6.6	E1/T1 BALANCED CABLE.....	153
6.7	E1 UNBALANCED CABLE.....	154
6.8	ETHERNET CABLE	155
6.9	DSL CABLE	156
6.10	POWER CORD	157
6.11	ILLUSTRATION OF LOOPBACK CONNECTION DEVICE (E1).....	158
6.12	ILLUSTRATION OF LOOPBACK CONNECTION DEVICE (SERIAL).....	159

1. Introduction

The G.SHDSL.bis NTU offers four different interfaces (E1, T1, Serial and Ethernet) connecting customers to high-speed TDM services. This series have 12 models as following:-

E1 interface model (SHDTU03b-E1):

This modem offers two different ways to connect customers to G.703 E1 interfaces. Either balanced 120Ω with RJ45 jack or unbalanced 75Ω with dual BNCs. The G.703 interface can carry data at rates of 64kbps to 2.048Mbps.

E1/T1 interface model (SHDTU03b-E1/T1):

This modem offers both European standard E1 and ANSI standard T1 with either balanced 120Ω with RJ45 jack or unbalanced 75Ω with dual BNCs for E1 or balanced 100Ω with RJ45 jack for T1. The G.703 interface can carry data at rates of 64kbps to 2.048Mbps.

Serial interface model (SHDTU03b-Data):

This modem offers the customer premise a high-speed TDM serial data service with a DB25 interface. The industry standard DB25 interface can be configured for V.35/RS530 or V.36/X.21 connection. The DB25 interface can transfers data up to 5.696Mbps (for 2-wire model) or up to 11.392Mbps (for 4-wire model).

Ethernet interface model (SHDTU03b-ET100):

This modem offers the customer premise high-speed TDM services with a LAN interface. The industry standard LAN interface can detect a 10M or 100M connection automatically. The Ethernet LAN traffic is encapsulated into standard HDLC packets.

(3 in 1) Multi-interface model (E1+Serial+Ethernet) (SHDTU03b-31):

This modem offers three types of interfaces: E1 interface (balanced 120Ω RJ45 jack or unbalanced 75Ω dual BNCs), Serial interface (DB25 female connector) and Ethernet interface (RJ-45 connector). You can select one of the following: (a) E1 interface only (b) Serial interface only (c) Ethernet interface only (d) E1 and Serial interface (e) E1 and Ethernet interface.

(4 in 1) Multi-interface model (E1+T1+Serial+Ethernet) (SHDTU03b-31T):

This modem offers four types of interfaces: E1 interface (balanced 120Ω RJ45 jack or unbalanced 75Ω dual BNCs), T1 interface (balanced 100Ω RJ45 jack), Serial interface (DB25 female connector) and Ethernet interface (RJ-45 connector). You can select one of the following: (a) E1 interface only (b) T1 interface only (c) Serial interface only (d) Ethernet interface only (e) E1 and Serial interface (f) E1 and Ethernet interface (g) T1 and Serial interface (h) T1 and Ethernet interface.

The modems in this series can all be configured locally with either menu driven LCD and menu keys or with menu-driven VT100 compatible Asynchronous Terminal Interface. Remote configuration is supported when DSL link exists via EOC (Embedded Operations Channel) and when using VT100 Asynchronous Terminal Interface.

The G.SHDSL.Bis NTU is equipped with an auto rate capability that identifies the maximum line rate supported by the copper loop. This powerful automatic configuration capability makes installation and service provisioning simple and painless. Further flexibility is provided as the ability to manually set the maximum NTU speed at different levels for different customer-tailored service offerings.

1.1 Features

- Standard G.SHDSL.Bis ITU G.991.2 (2004) supports improved reach/speed and greater interoperability
- Fast and cost-effective provisioning of traditional frame relay (FR or T-HDLC) or TDM leased line services
- Uses existing copper loop infrastructures
- Can operate in point to point connection
- Efficient single wire pair usage
- Up to 5.696Mbps(2-wire) or 11.392Mbps(4-wire) symmetric service bit rate
- Auto rate installation maximizes data rate based on loop conditions
- Auto configuration wetting current to protect SHDSL line
- Local management interface with LCD display
- Remote line loopback
- SHDSL Line performance monitoring
- Raw and per time interval statistics
- Bandwidth guaranteed transmission equipment
- Remote firmware upgrade

1.2 Specification

WAN Interface

- Line Rate: ITU G.991.2 (2004)
- Coding: trellis coded pulse amplitude modulation (TC-PAM16 and TC-PAM32)
- Support: Annex A ,B , F and G
- Payload rates: 64Kbps to 5.696Mbps (N=1 to 89) for 2-wire model
128Kbps to 11.392Mbps (N=2 to 178) for 4-wire model
- Connection: RJ-45 jack (2-wire or 4-wire)
- Impedance: 135 ohms

G.703 Interface (as E1)

- Connection: RJ-48C for balanced 120Ω E1 cable and BNC for unbalanced 75Ω E1 coaxial cable
- Line Rate : 2048KHz +/- 50ppm
- Line code: HDB3/AMI
- Framing : PCM30/PCM30C/PCM31/PCM31C and Unframed
- Data Rate : 64Kbps to 2.048Mbps (Nx64Kbps , N=1 to 32)
- Operation : Full E1 and Fractional E1

G.703 Interface (as T1)

- Connection: RJ-48C for balanced 100Ω T1 cable
- Line Rate : 1544KHz +/- 50ppm
- Line code: B8ZS
- Framing: SF/ESF/Unframed
- Data Rate : 64kbps to 1.536Mbps (N=1 to 24)
- Operation : Clear Channel and Fractional T1

Serial Interface (as RS-530/V.35/X.21)

- Payload rates: Up to 5.696Mbps(for 2-wire model) or Up to 8.192Mbps(for 4-wire model)
- Support V.35/RS-530 or V.36/X.21 with cable solution

LAN Interface (as Ethernet)

- Single Ethernet Interface
- 10/100Mbps Half/Full Duplex, Auto-sensing, Auto-Crossover
- Up to 1024 MAC address learning, filtering bridge

DSL Timing

- Internal
- From E1/T1 Recovery (as E1/T1)
- From DTE (as V.35 and Ethernet)

Performance Monitoring

- ES, SES, UAS, LOWS for SHDSL
- ES, SES, UAS for E1
- Alarms and Errors for SHDSL or interface

Loopback Tests (for E1, T1 and V.35 interface only)

- Local Digital Loopback
- Local Loopback
- Remote Line Loopback
- Remote Payload Loopback
- Far-end Line Loopback
- Far-end Payload Loopback
- V.54 Loopback (for V.35 interface)
- Build-in 2047(2¹¹-1) bit BER tester

Management

- Configuration with keypads and LCD display
- Console port (RJ45 , RS232C)
- Support firmware upgradeable

Physical/Electrical

- Dimensions: 19.8 x 4.6 x 16.8 cm
- AC Input: 90~240V with 50~60Hz
- DC Input: -48V
- Power Consumption: 10W Max
- Operation temperature: 0 to 50°C
- Humidity: Up to 95% (non-condensing)
- External screw for frame grounding

Products Information:

	Interface	2-wire	4-wire
Single Interface model	E1	SHDTU03b-E1	SHDTU03bA-E1
	Serial	SHDTU03b-V35	SHDTU03bA-V35
	Ethernet	SHDTU03b-ET100	SHDTU03bA-ET100
Multi Interface model	E1+T1	SHDTU03b-E1/T1	SHDTU03bA-E1/T1
	E1+Series+Ethernet	SHDTU03b-31	SHDTU03bA-31
	E1+T1+Serial+Ethernet	SHDTU03b-31T	SHDTU03bA-31T

1.3 Applications

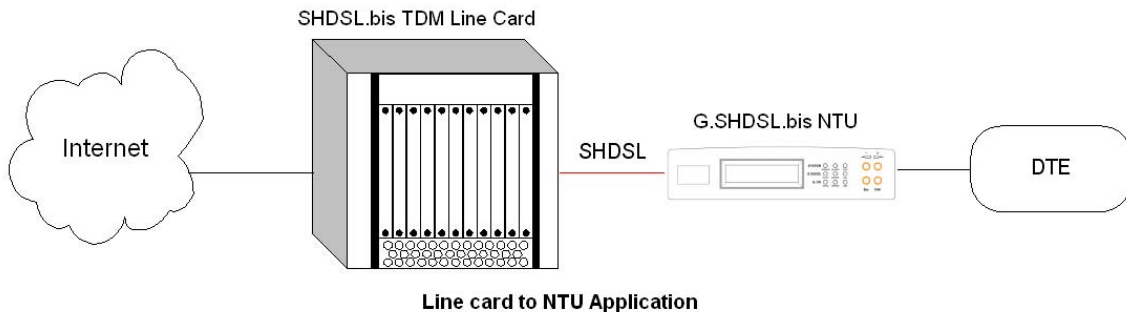

2. Getting to know the SHDSL.bis NTU

This chapter shows the front and rear panel and how to install the hardware.

The models listing on G.SHDSL .bis NTU series:

Interface type	2/4 wires	AC Power supply	DC Power supply	AC & DC Dual Power supply
E1	2	SHDTU03b-E1-AC	SHDTU03b-E1-DC	SHDTU03b-E1-AD
	4	SHDTU03bA-E1-AC	SHDTU03bA-E1-DC	SHDTU03bA-E1-AD
Serial	2	SHDTU03b-V35-AC	SHDTU03b-V35-DC	SHDTU03b-V35-AD
	4	SHDTU03bA-V35-AC	SHDTU03bA-V35-DC	SHDTU03bA-V35-AD
Ethernet	2	SHDTU03b-ET100-AC	SHDTU03b-ET100-DC	SHDTU03b-ET100-AD
	4	SHDTU03bA-ET100-AC	SHDTU03bA-ET100-DC	SHDTU03bA-ET100-AD
E1+T1	2	SHDTU03b-E1/T1-AC	SHDTU03b-E1/T1-DC	SHDTU03b-E1/T1-AD
	4	SHDTU03bA-E1/T1-AC	SHDTU03bA-E1/T1-DC	SHDTU03bA-E1/T1-AD
E1+Serial+Ethernet	2	SHDTU03b-31-AC	SHDTU03b-31-DC	SHDTU03b-31-AD
	4	SHDTU03bA-31-AC	SHDTU03bA-31-DC	SHDTU03bA-31-AD
E1+T1+Serial+Ethernet	2	SHDTU03b-31T-AC	SHDTU03b-31T-DC	SHDTU03b-31T-AD
	4	SHDTU03bA-31T-AC	SHDTU03bA-31T-DC	SHDTU03bA-31T-AD

2.1 Front Panel

2.1.1. E1 interface model

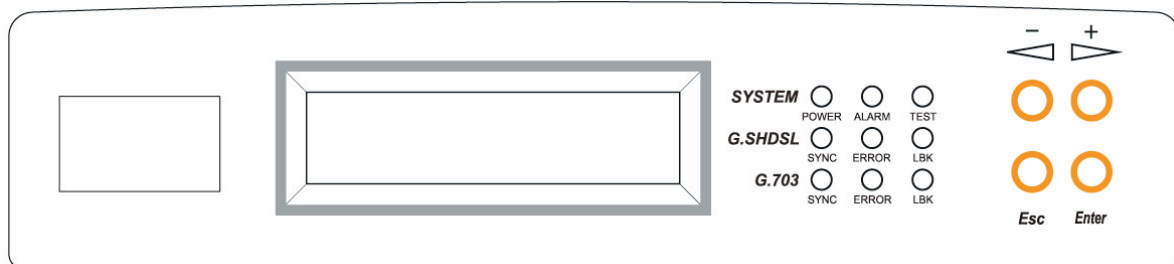

2.1.2. Serial interface model

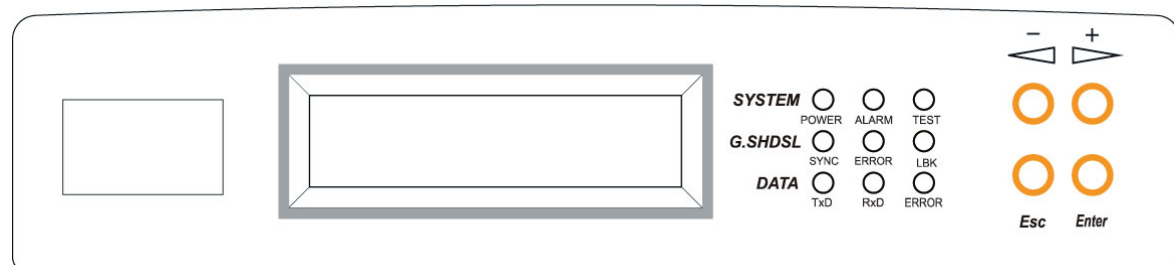

2.1.3. Ethernet interface model

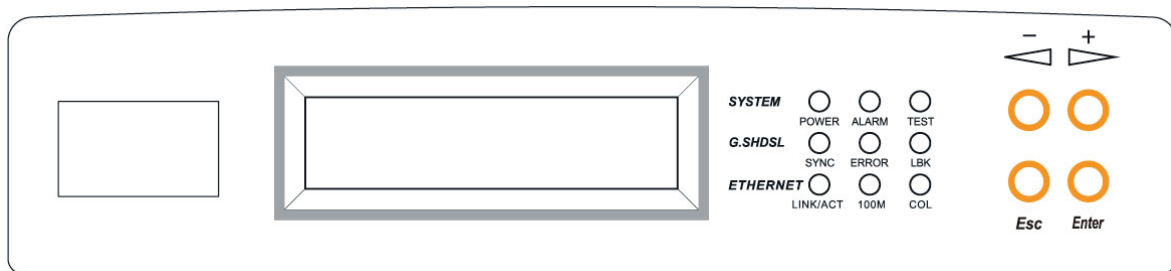

2.1.4. Multi-interfaces model

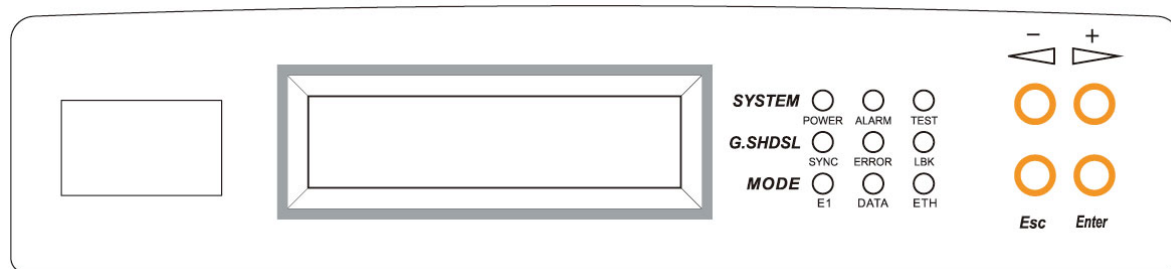

Front panel can be separated into three parts: LCD display, LED indicator and Keypads.

The LCD display can show the status and configuration of the device. The local management interface will be done by keypad with this LCD display.

The purpose of the keypad is to configure the setting or function selection on this NTU.

The following table describes the LEDs' functions of the SHDSL.bis NTU:

LED	Color	Action	Description
PWR	Green	On	Power is on.
		Off	Power is off.
ALM	Red	On	System loss.
		Off	System is working normally.
TST	Yellow	On	System is testing for connection.
		Off	System is working normally.
SHDSL	Green	On	SHDSL line is connected.
		Blink	Data transmit in SHDSL line.
		Off	SHDSL line is dropped.
	Red	Blink	Error second occurs.
		Off	No error second.
	Yellow	On	Loopback is on.
Off		Loopback is off.	

E1	SYN	Green	On	E1 line is connected.
			Off	E1 line is dropped.
	ERR	Red	Blink	There are error seconds.
			Off	There is not any error second.
	LPB	Yellow	On	Loopback is on.
			Off	Loopback is off.
V.35	TD	Green	On	Data transmit in V.35.
			Off	No data transmit in V.35.
	RD	Green	On	Data receive in V.35.
			Off	No data receive in V.35.
	ERR	Red	Blink	Error second occurs.
			Off	No error second.
ETH	LINK	Green	On	Data transmit in Ethernet.
			Off	No data transmit in Ethernet.
	100M	Green	On	Data receive in 100M.
			Off	No data receive in 100M.
	COL	Red	Blink	Error collision occurs.
			Off	No error collision.
MODE	E1	Green	Blink	E1 Data transmit and receive
			On	E1 cable cable connected
		Red	On	No E1 cable connected
	SER	Green	Blink	Serial Data transmit and receive
			On	DTE Connected
		Red	On	DTE Disconnect
	ETH	Green	Blink	Ethernet Data transmit and receive
			On	Ethernet cable connected
		Red	On	No Ethernet cable connected

2.2 Rear Panel

2.2.1. E1/T1 Interface Model

AC power input version

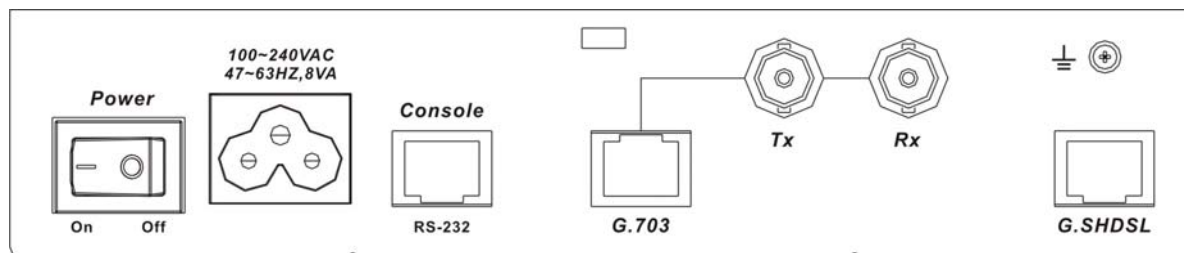

The rear panel of this model is including power switch, AC power socket, RJ-45 console, G.703 RJ-48C jack or BNC jack for transmitting and receiving and RJ-45 for DSL cable from left to right.

DC power input version

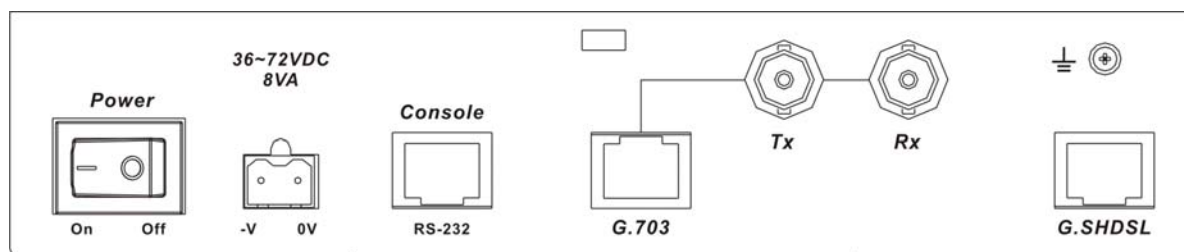

The rear panel of this model is including power switch, DC power socket, RJ-45 console, G.703 RJ-48C jack or BNC jack for transmitting and receiving and RJ-45 for DSL cable from left to right.

AC & DC dual power input version

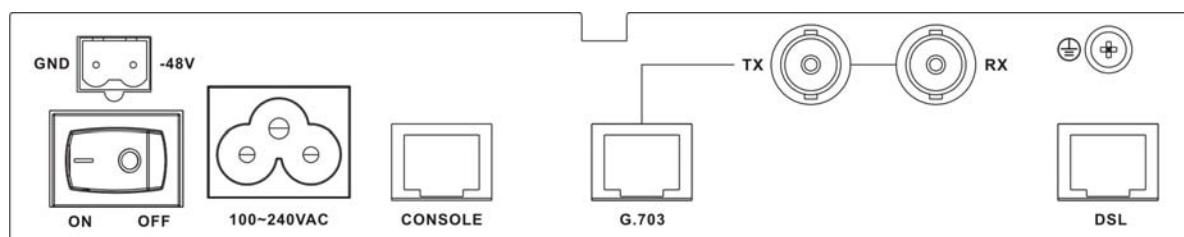

The rear panel of this model is including DC power socket, AC power switch, AC power socket, RJ-45 console, G.703 RJ-48C jack or BNC jack for transmitting and receiving and RJ-45 for DSL cable from left to right.

Connector Description

ON	Power switch. Press 1 for turn on and press 0 for off
90~240V AC	IEC-320 C6 AC input connector. It has power adapting function from 90V to 240V
-48V GND	DC power input connector (-48V)
CONSOLE	RJ-45 for system configuration and maintenance
G.703	RJ-48C for 120Ω E1/T1 connection with PABX (Private Automatic Branch Exchange) or E1 Router
TX	BNC for 75Ω E1 transmitting
RX	BNC for 75Ω E1 receiving
SHDSL	RJ-45 for DSL connection

2.2.2. Serial Interface Model

AC power input version

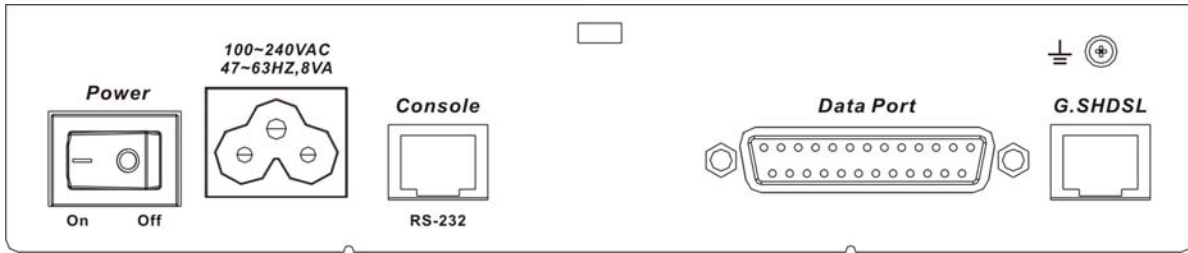

The rear panel of this model is including power switch, AC power socket, RJ-45 for console cable, DB-25(Female) for serial cable and RJ-45 for DSL cable from left to right.

DC power input version

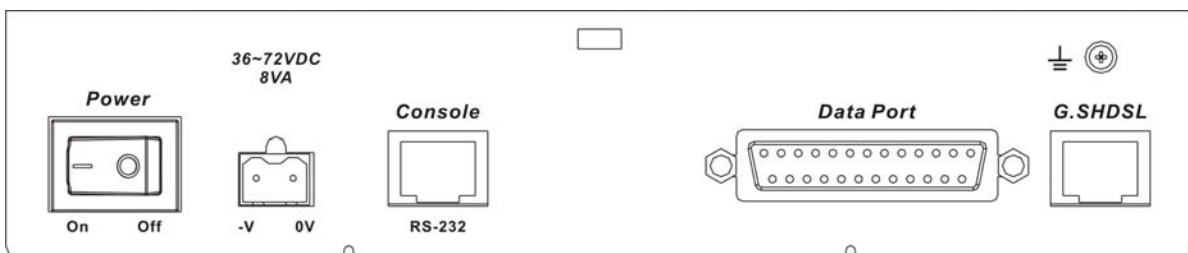

The rear panel of this model is including power switch, DC power socket, RJ-45 for console cable, DB-25(Female) for serial cable and RJ-45 for DSL cable from left to right.

AC & DC dual power input version

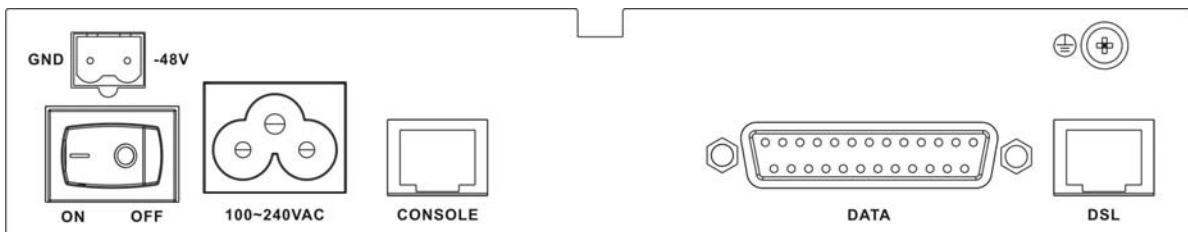

The rear panel of this model is including DC power socket, AC power switch, AC power socket, RJ-45 for console cable, DB-25(Female) for serial cable and RJ-45 for DSL cable from left to right.

Connector Description

ON	Power switch. Press 1 for turn on and press 0 for off.
90~240V AC	IEC-320 C6 AC input connector. It has power adapting function from 90V to 240V
-48V GND	DC power input connector (-48V)
CONSOLE	RJ-45 for system configuration and maintenance
SERIAL	DB-25(F) for RS-530 and V.35 or X.21(with adaptor cable)
SHDSL	RJ-45 for DSL Connection

2.2.3. Ethernet Interface Model

AC power input version

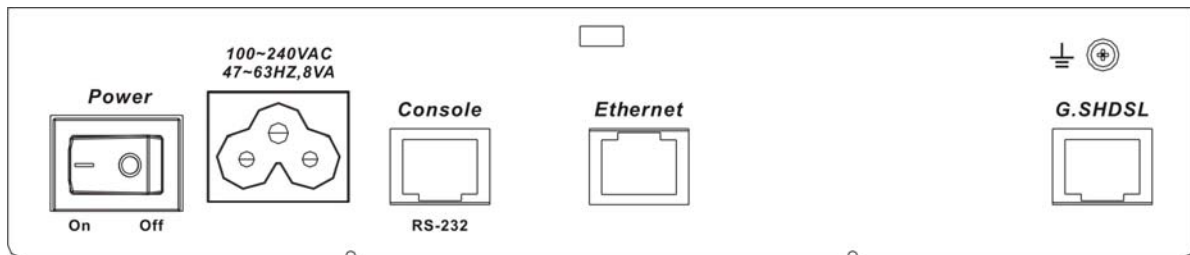

The rear panel of this model is including power switch, AC power socket, RJ-45 for console cable, LAN for Ethernet cable and RJ-45 for DSL cable from left to right.

DC power input version

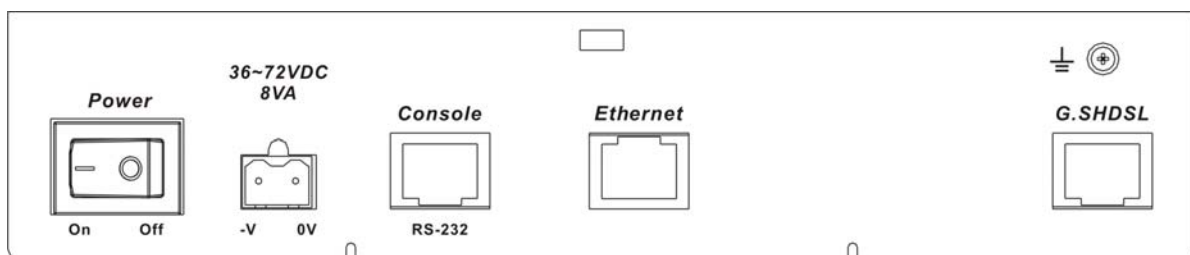

The rear panel of this model is including power switch, DC power socket, RJ-45 for console cable, LAN for Ethernet cable and RJ-45 for DSL cable from left to right.

AC & DC dual power input version

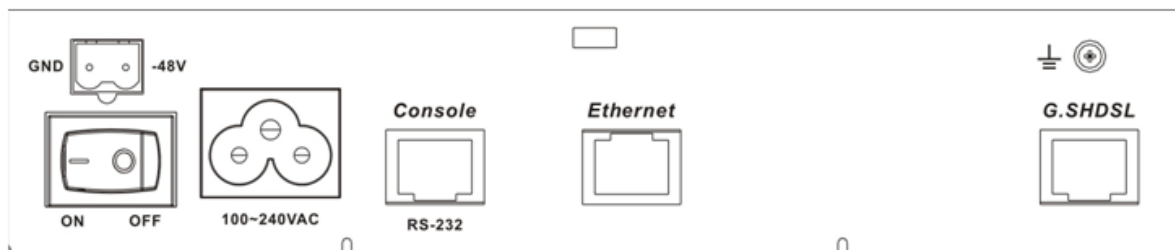

The rear panel of this model is including DC power socket, AC power switch, AC power socket, RJ-45 for console cable, LAN for Ethernet cable and RJ-45 for DSL cable from left to right.

Connector Description

ON	Power switch. Press 1 for turn on and press 0 for turn off.
90~240V AC	IEC-320 C6 AC input connector. It has power adapting function from 90V to 240V.
-48V GND	DC power input connector (-48V)
CONSOLE	RJ-45 for system configuration and maintenance.
ETH	RJ-45 LAN port for Ethernet cable
SHDSL	RJ-45 for DSL Connection

2.2.4. Multi-interfaces in one Model

DC power input version

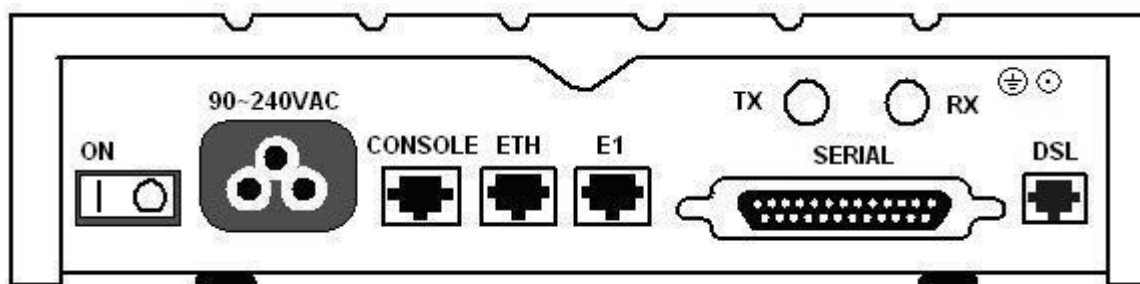

The rear panel of this model is including power switch, AC power socket, RJ-45 for console cable, LAN for Ethernet cable, G.703 RJ-48C or BNC jacks for transmitting and receiving, DB-25(Female) for serial cable and RJ-45 for DSL cable from left to right.

DC power input version

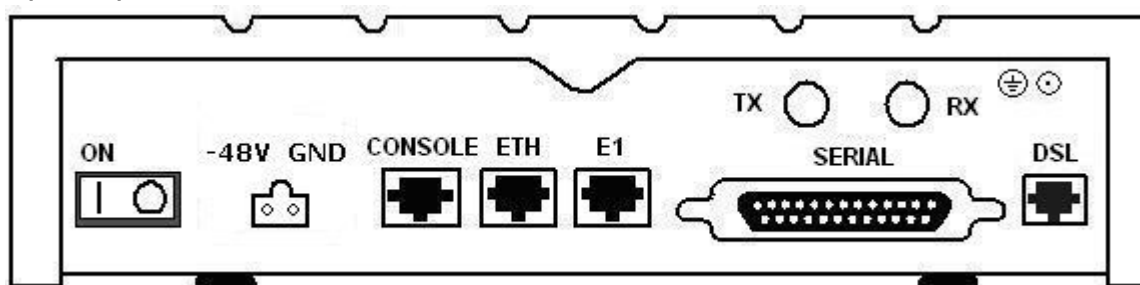

The rear panel of this model is including power switch, DC power socket, RJ-45 for console cable, LAN for Ethernet cable, G.703 RJ-48C or BNC jacks for transmitting and receiving, DB-25(Female) for serial cable and RJ-45 for DSL cable from left to right.

AC & DC dual power input version

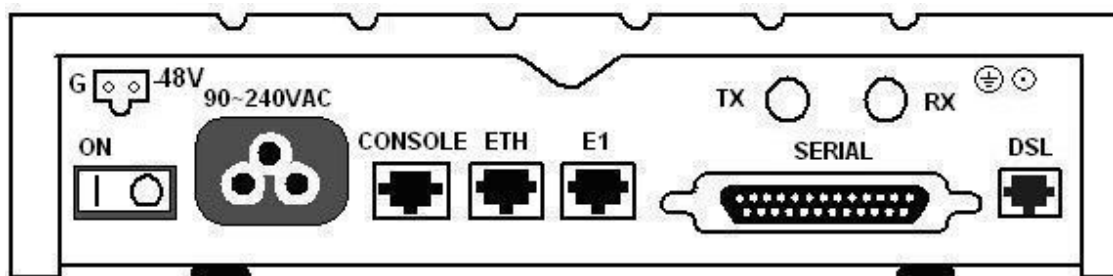

The rear panel of this model is including DC power socket, AC power switch, AC power socket, RJ-45 for console cable, LAN for Ethernet cable, G.703 RJ-48C or BNC jacks for transmitting and receiving, DB-25(Female) for serial cable and RJ-45 for DSL cable from left to right.

Connector Description

ON	Power switch. Press 1 for turn on and press 0 for off
90~240V AC	IEC-320 C6 AC input connector. It has power adapting function from 90V to 240V
-48V GND	DC power input connector (-48V)
CONSOLE	RJ-45 for system configuration and maintenance
ETH	RJ-45 LAN port for Ethernet cable
E1	RJ-48C for 120Ω E1/T1 connection with PABX (Private Automatic Branch Exchange) or E1 Router
SERIAL	DB-25(F) for RS-530 and V.35 or X.21(with adaptor cable)
TX	BNC for 75Ω E1 transmitting
RX	BNC for 75Ω E1 receiving
DSL	RJ-45 for DSL connection

2.3 Installation

Note: To avoid possible damage to this NTU, do not turn on the product before hardware installation.

- (a) Plug the power cord in the power socket.
- (b) Plug the console port in console if you want to configure the NTU with VT100 program of NB or PC.
- (c) Plug the E1/T1 cable (75Ω BNC cables for E1 or 120Ω cable for E1 or T1)
or/and SERIAL cable
or/and Ethernet cable
- (d) Plug SHDSL cable
- (e) Power on

2.3.1. E1/T1 Interface

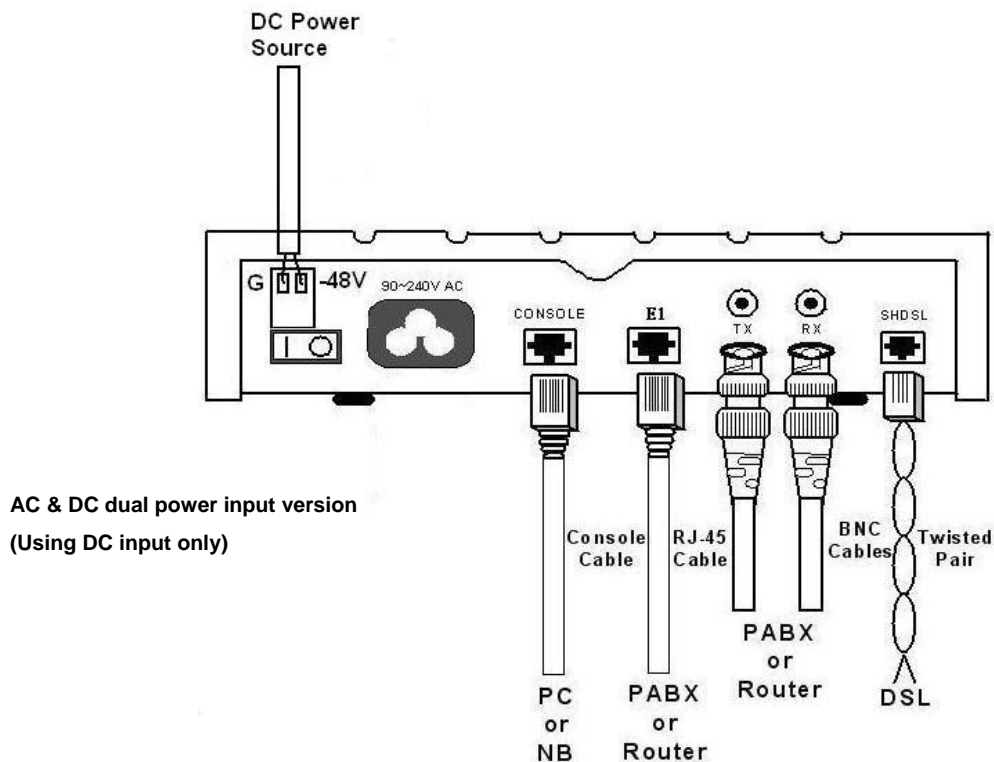
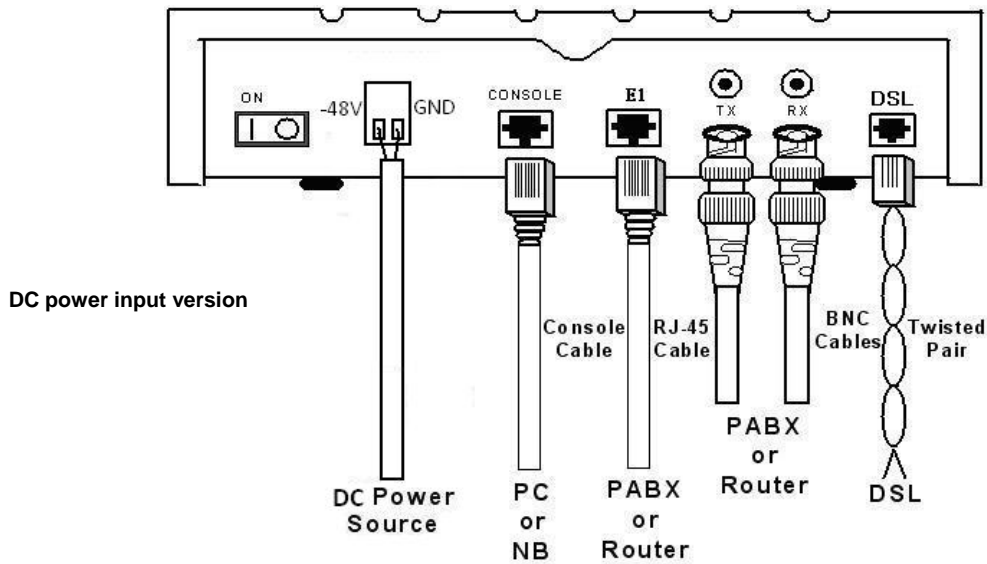
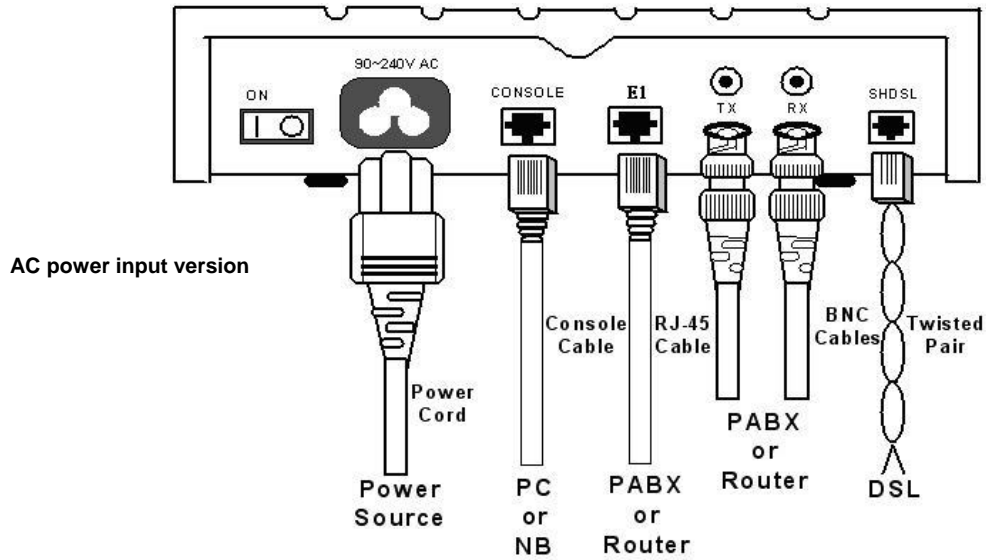

2.3.2. Serial Interface

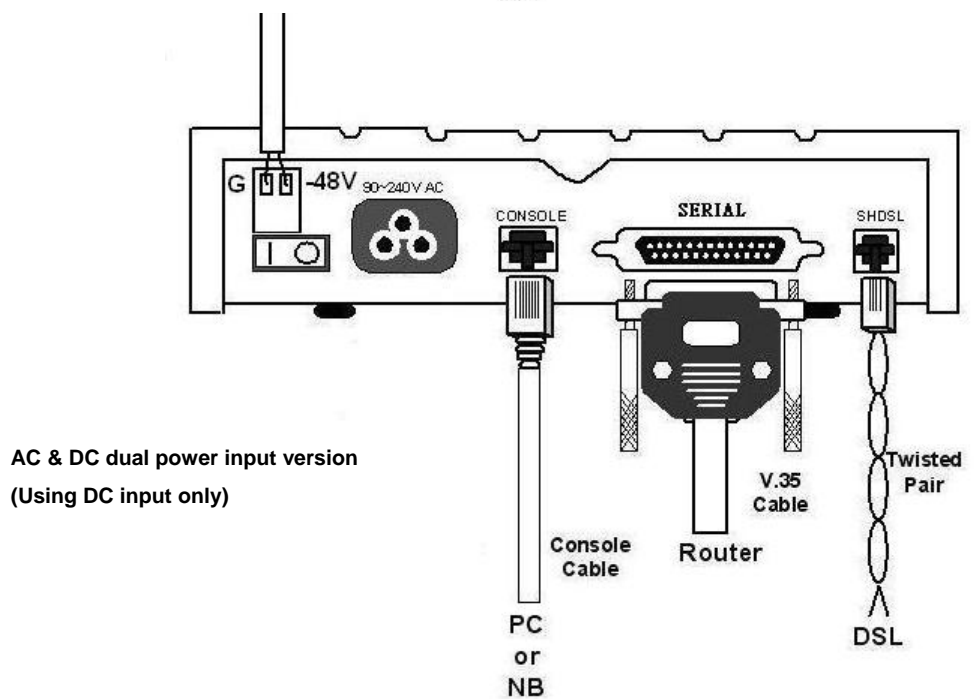
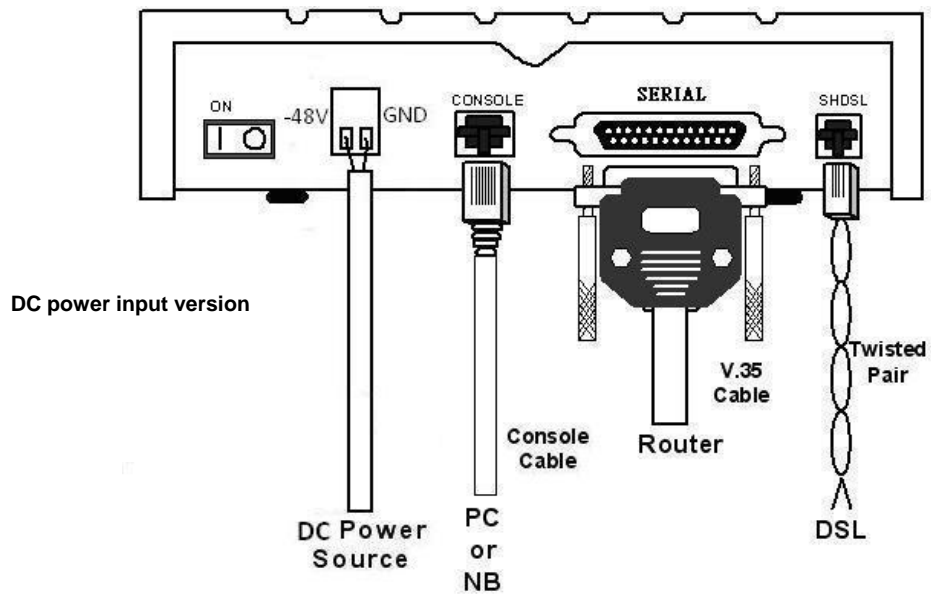
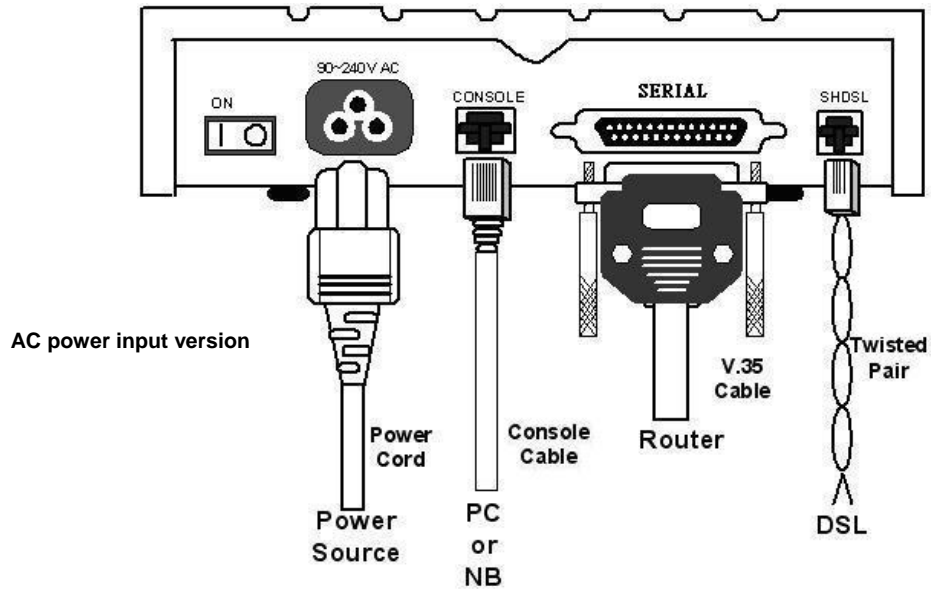

2.3.3. Ethernet Interface

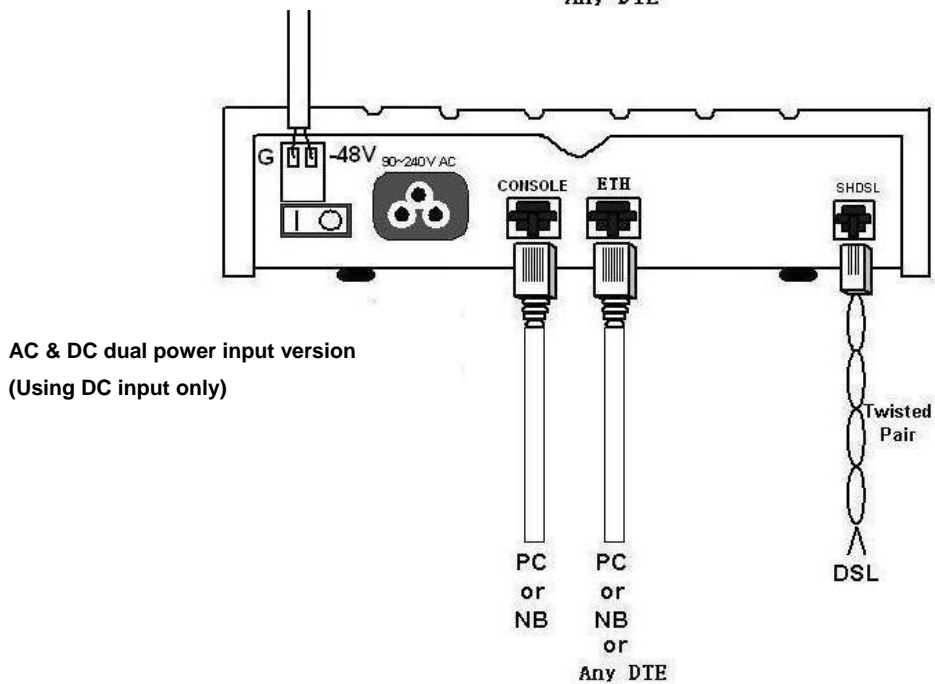
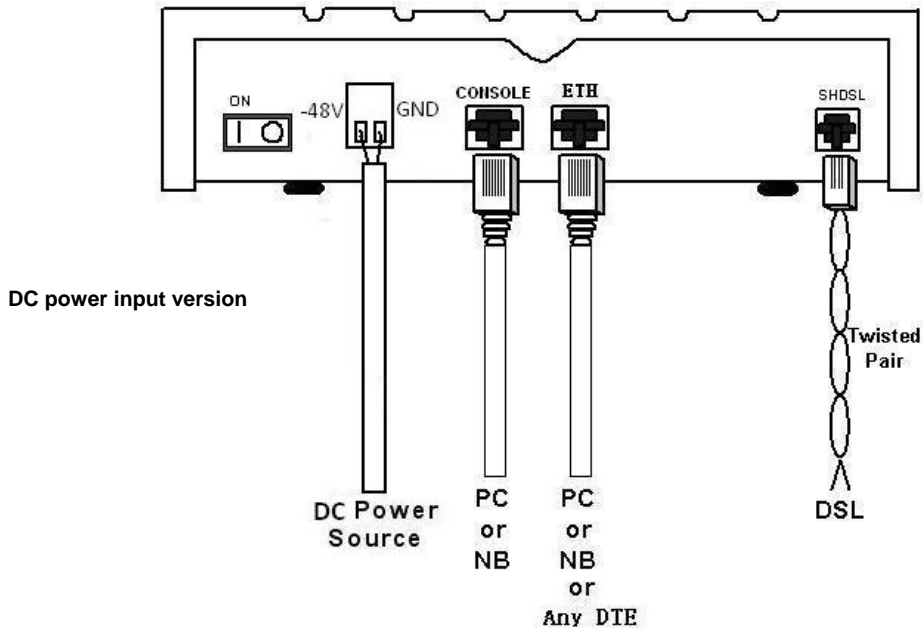
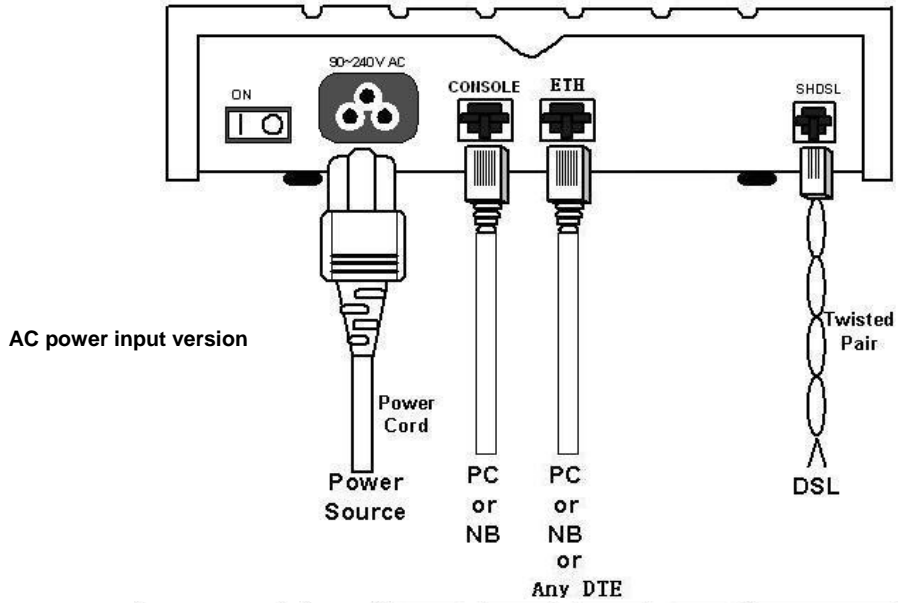



Protective earth:

The marked lug or terminal should be connected to the building protective earth bus.

The function of protective earth does not serve the purpose of providing protection against electrical shock, but instead enhances surge suppression on the DSL lines for installations where suitable bonding facilities exist.

We strongly recommend grounding this device for lightning protection purposes.

The connector type is M3 machine screw.



Warning! High voltage. Do not open the housing

There are no user serviceable parts inside the modem. Opening the unit while still connected to power source could cause exposure to danger high voltages. All service should be done by trained personnel.

Product servicing

Do not attempt to service this product yourself, as opening or removing covers may expose you to dangerous voltage points or other risks. Refer all servicing to qualified service personnel.

1. Unplug this product from the wall outlet and refer servicing to qualified service personnel when:
2. The power card or plug is damaged, cut or frayed
3. Liquid was spilled into the product
4. The product was exposed to rain or water
5. The product has been dropped or the case has been damaged
6. The product exhibits a distinct change in performance, indicating a need for service
7. The product does not operate normally after following the operating instructions

Note: Adjust only those controls that are covered by the operating instructions, since improper adjustment of other controls may result in damage and will often require extensive work by a qualified technician to restore the product to normal condition.

Disposal instructions

Do not throw this electronic device into the trash when discarding.

To minimize pollution and ensure utmost protection of the global environment, please recycle this device.

3. Configuration with Keypad and LCD

This chapter provides information about the configuration of your G.SHDSL .Bis NTU via front panel LCD display and keypads.

3.1 Keypad

The G.SHDSL.bis NTU is designed to provide an user-friendly configuration and management by using keypad and LCD display on the front panel without a computer with the VT100 terminal software connected.



Key Pad	Description
ESC ●	Return to previous configuration menu.
Enter ●	Skip to next configuration menu or configure this item.
L- ▲	Select other parameter in the same level menu.
R+ ▼	Select other parameter in the same level menu.

3.2 Main menu Tree

Model vs. Interface modes support (table 1):

Model	Interface modes support
SHDTU03b-E1; SHDTU03bA-E1 E1 interface model	E1 interface
SHDTU03b-E1/T1; SHDTU03bA-E1/T1 E1 + T1 interface model	E1 interface
	T1 interface
SHDTU03b-V35; SHDTU03bA-V35 Serial interface model	Serial interface (V.35 , X.21)
SHDTU03b-ET100; SHDTU03bA-ET100 Ethernet interface model	Ethernet interface
SHDTU03b-31; SHDTU03bA-31 E1+Serial+Ethernet interface model	E1 interface
	Serial interface (V.35 , X.21)
	Ethernet interface
	E1+Serial(V.35 , X.21)
	E1+Ethernet interface
SHDTU03b-31T; SHDTU03bA-31T E1+T1+ Serial +Ethernet interface model	E1 interface
	T1 interface
	Serial interface (V.35 , X.21)
	Ethernet interface
	E1+Serial (V.35 , X.21)
	E1+Ethernet interface
	T1 + Serial (V.35 , X.21)
	T1 + Ethernet interface

Model vs. Interface modes support (table 2):

Interface		E1	T1	Serial	Ethernet	E1+Serial	E1+Ethernet	T1+Serial	T1+Ethernet
2-wire	4-wire								
-E1	A-E1	•							
-E1/T1	A-E1/T1	•	•						
-V35	A-V35			•					
-ET100	A-ET100				•				
-31	A-31	•		•	•	•	•		
-31T	A-31T	•	•	•	•	•	•	•	•

* = SHDTU03b

After turning on device, the LCD display will prompt **G.SHDSL .BIS NTU**. Press **Enter** to enter. The display will follow the sub-menus as in the following graphic:

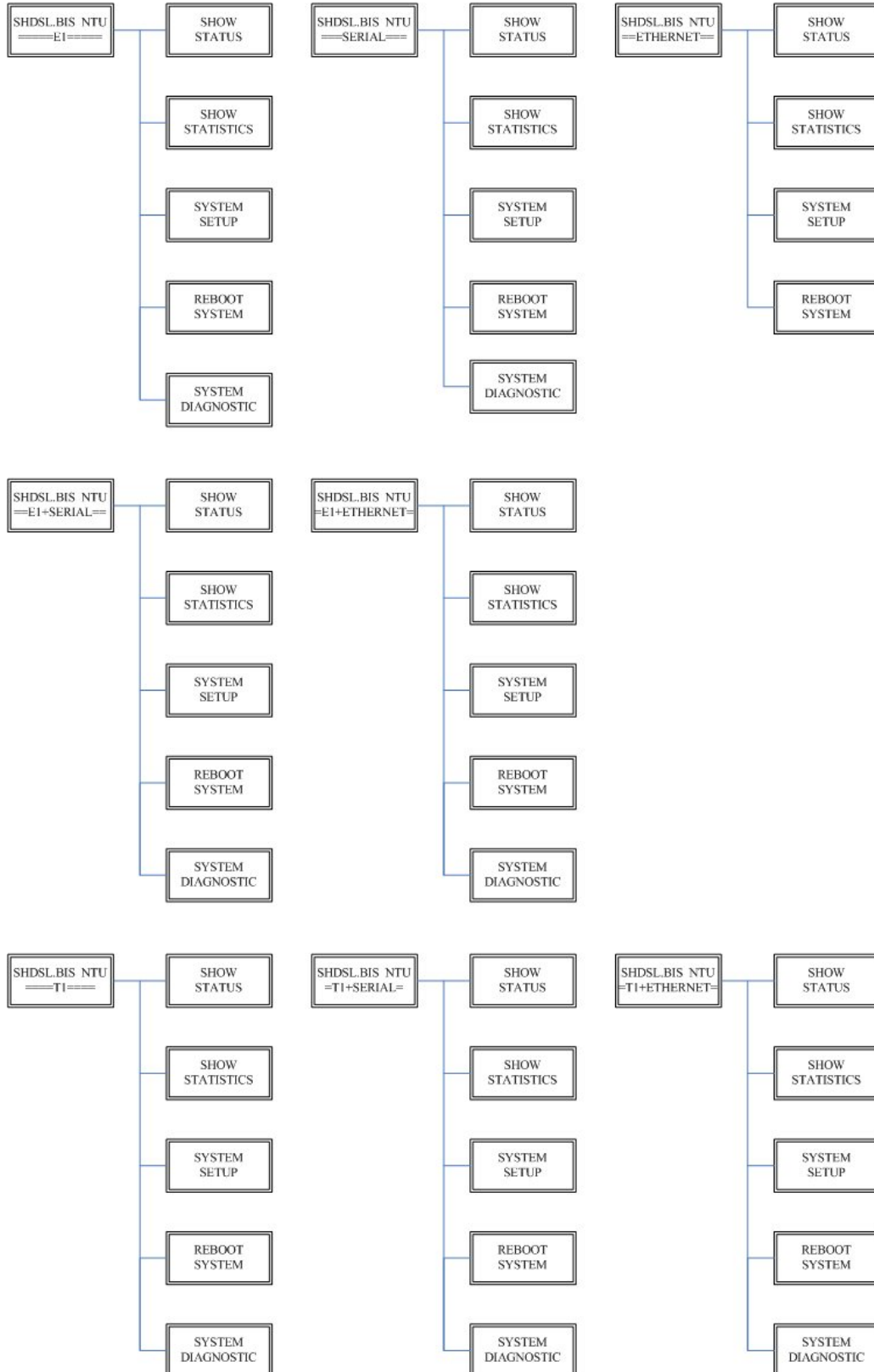

Please notice that the Ethernet interface mode does not have SYSTEM DIAGNOSTIC. For more detail on these sub-menus, please refer to each chapter.

3.3 Menu tree for SHOW STATUS

You can check the status via LCD display.

The SHOW STATUS menu tree is as following.

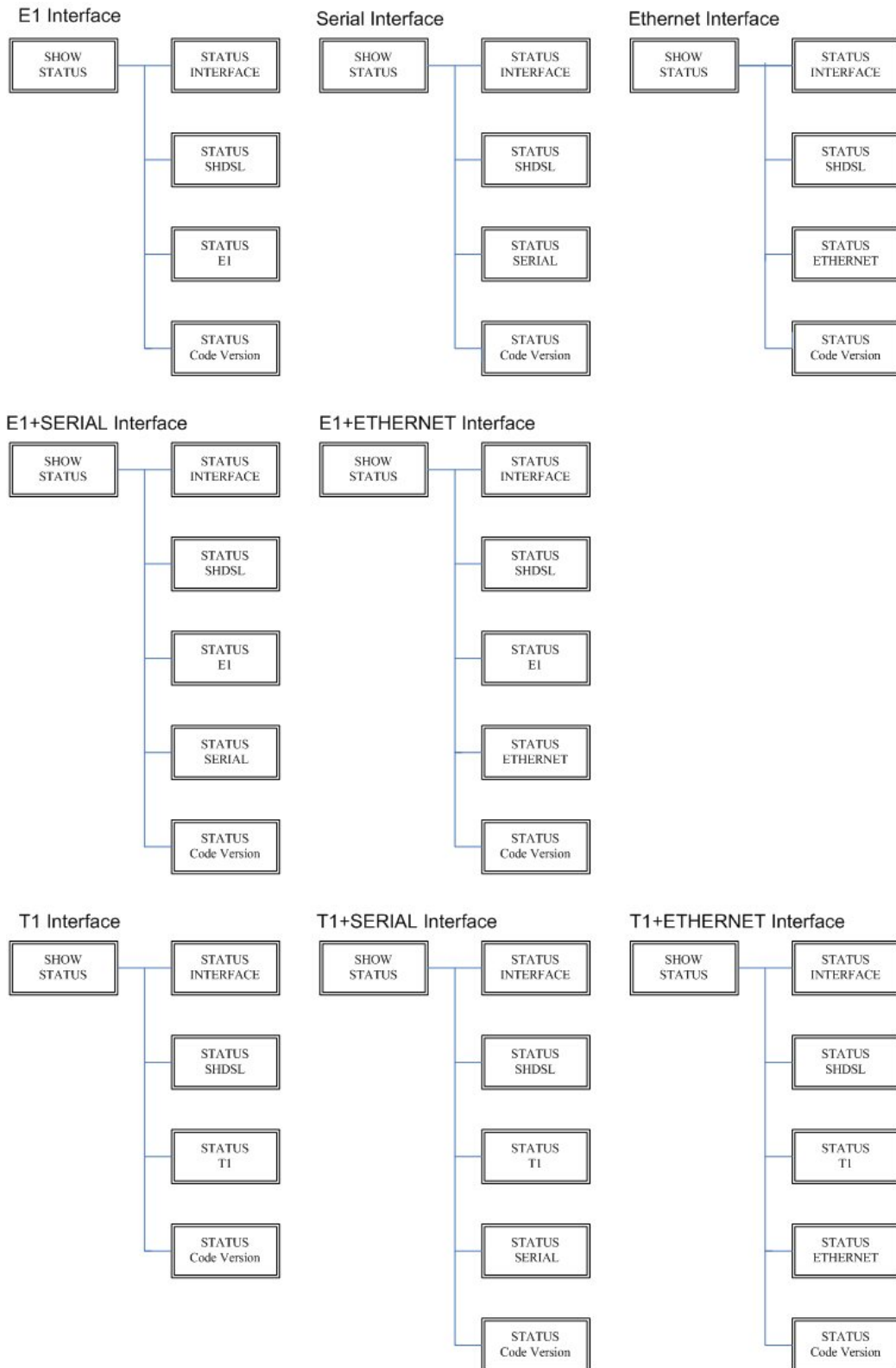

For more detail on these sub-menus, please refer to following:

SHOW STATUS > STATUS SHDSL



SHOW STATUS > STATUS EI

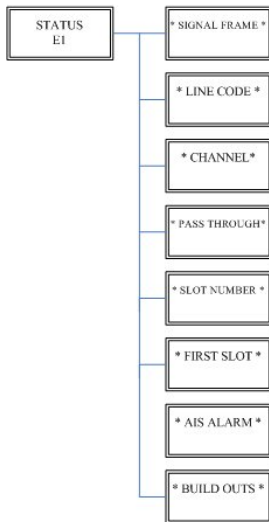

SHOW STATUS > STATUS SERIAL

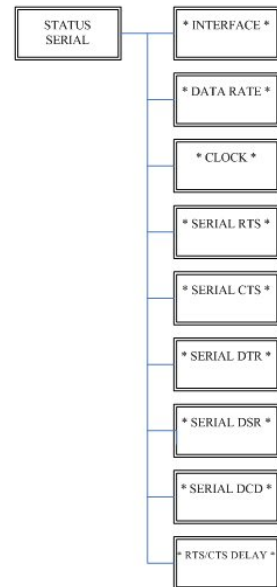

SHOW STATUS > STATUS ETHERNET

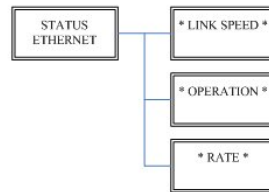

SHOW STATUS > STATUS T1

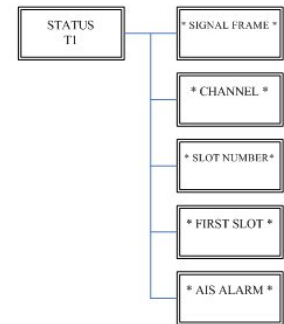

3.4 Menu tree for SHOW STATISTICS

The product can display two kinds of statistics data:

- (a) Current 15 minutes period and 96 previous 15-minutes periods of SHDSL performance.
- (b) Current 24 hour period and 7 previous 24-hours periods of SHDSL performance.

SHDSL's statistics data:

SHDSL
ES
SES
UAS
LOSW

If using the E1 interface mode, it can also show the E1 performance data.

- (c) Current 15 minutes period and 96 previous 15-minutes periods of E1 performance.
- (d) Current 24 hours period and 7 previous 24-hours periods of E1 performance.

E1's statistics data:

E1
ES
SES
UAS

Abbrev of statistics terms:

ES	Error Second
SES	Severely Error Second
UAS	Unavailable Second
LOWS	Loss of Synchronization word

Model vs. Interface modes and statistics support:

Model	Interface modes support	SHDSL	E1
		statistics support ES ,SES,UAS,LOSW	statistics support ES,SES,UAS
SHDTU03b-E1, A-E1 E1 interface model	E1 interface	•	•
SHDTU03b-E1/T1, A-E1/T1 E1 + T1 interface model	E1 interface	•	•
	T1 interface	•	
SHDTU03b-V35, A-V35 Serial interface model	Serial interface (V.35 , X.21)	•	
SHDTU03b-ET100, A-ET100 Ethernet interface model	Ethernet interface	•	
SHDTU03b-31, A-31 E1+Serial+Ethernet interface model	E1 interface	•	•
	Serial interface (V.35 , X.21)	•	
	Ethernet interface	•	
	E1+Serial(V.35 , X.21) interface	•	•
	E1+Ethernet interface	•	•
SHDTU03b-31T, A-31T E1+T1+ Serial +Ethernet interface model	E1 interface	•	•
	T1 interface	•	
	Serial interface (V.35 , X.21)	•	
	Ethernet interface	•	
	E1+Serial (V.35 , X.21) interface	•	•
	E1+Ethernet interface	•	•
	T1 + Serial (V.35 , X.21) interface	•	
	T1 + Ethernet interface	•	

3.4.1. Show Statistic on E1 Interface

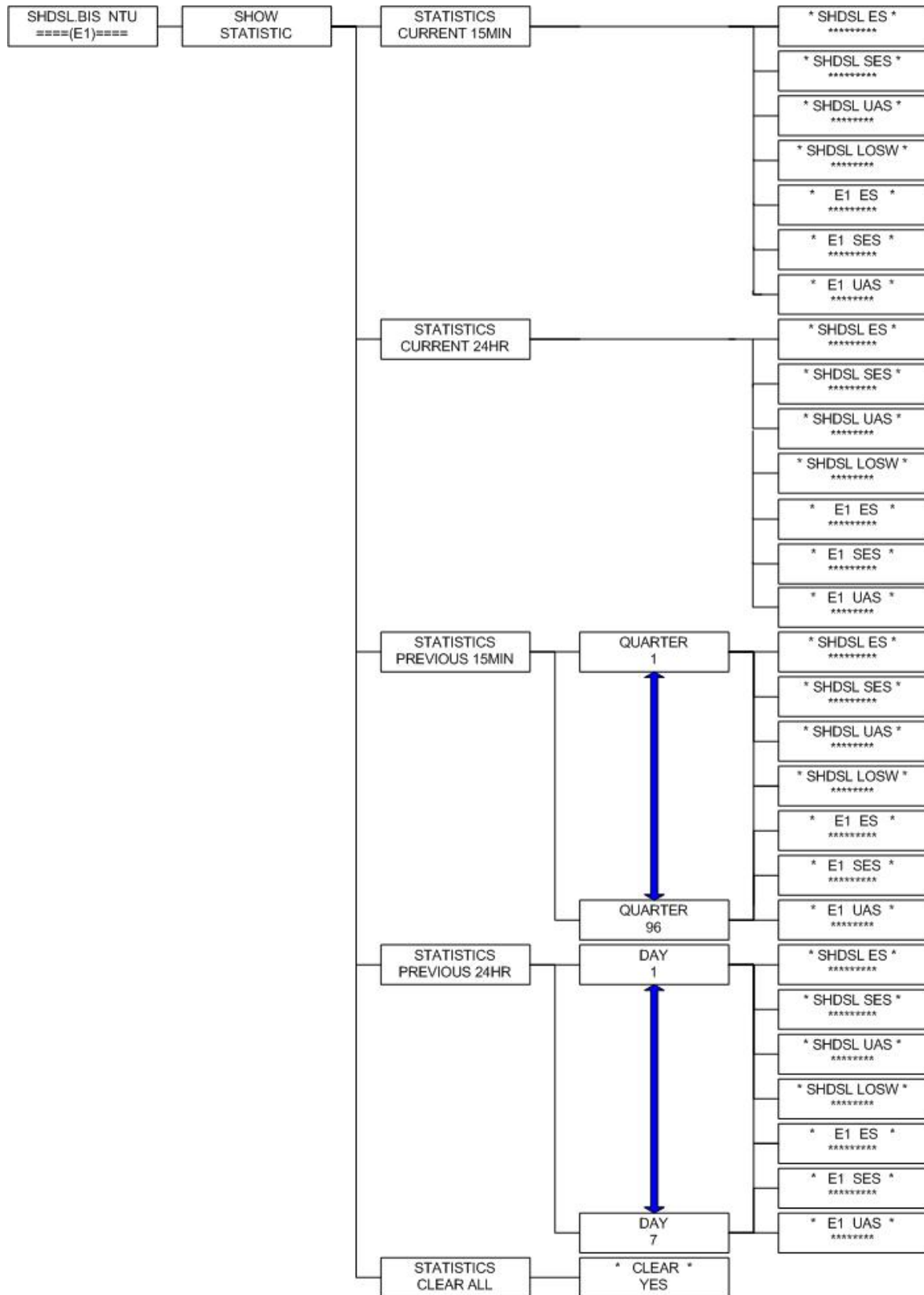

3.4.2. Show Statistic on Serial/Ethernet/T1 Interface

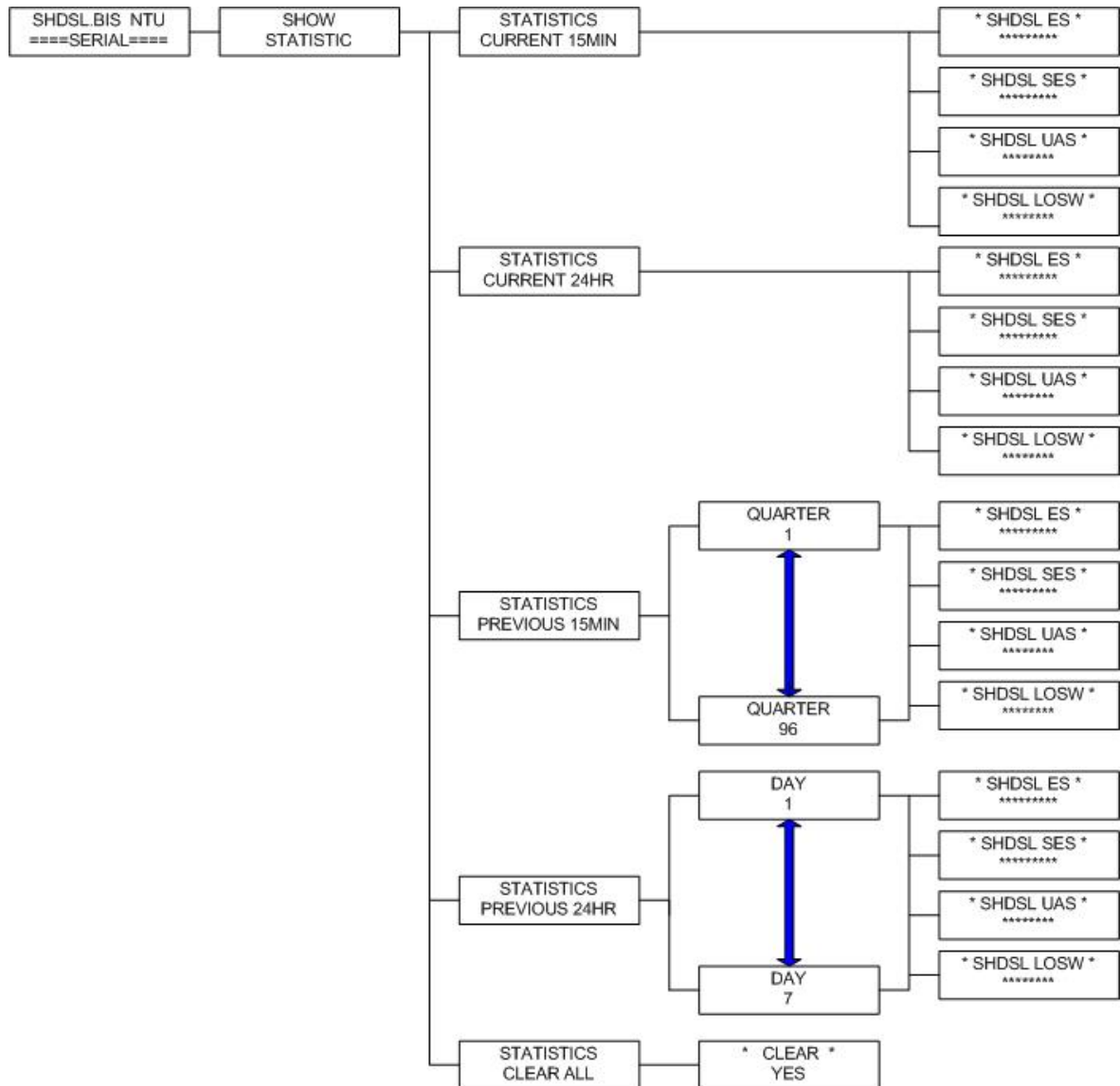

3.5 Menu tree for SYSTEM SETUP

You can setup five interface modes via LCD display.

E1 Interface Mode

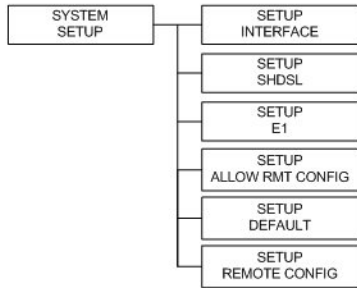

Serial Interface Mode

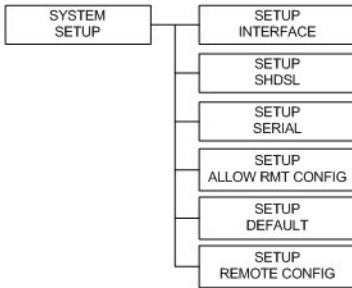

Ethernet Interface Mode

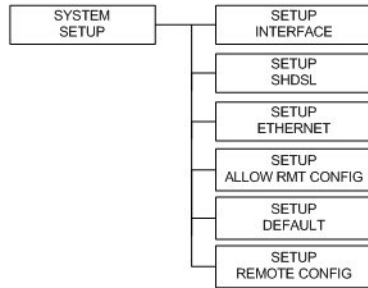

E1 + Series Interface Mode

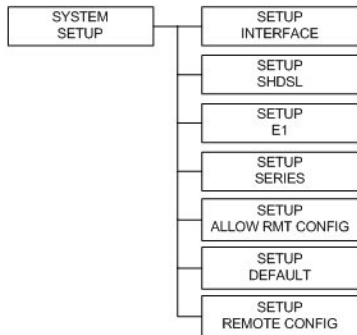

E1 + Ethernet Interface Mode

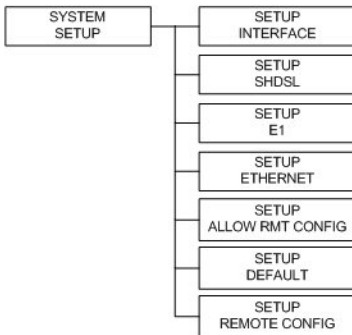

T1 Interface Mode

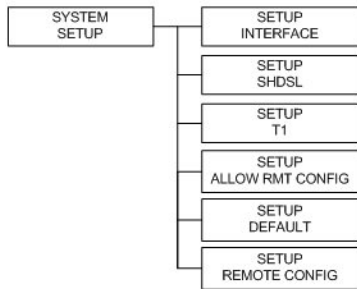

T1 + Series Interface Mode

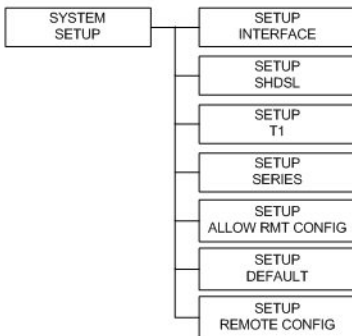

T1 + Ethernet Interface Mode

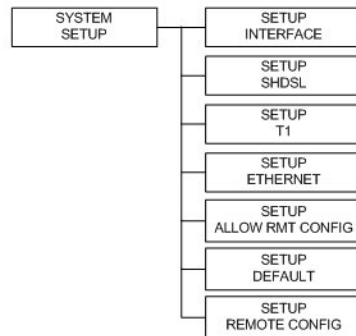

3.5.1. Sub-Menu tree for SETUP SHDSL

SYSTEM SETUP > SETUP SHDSL

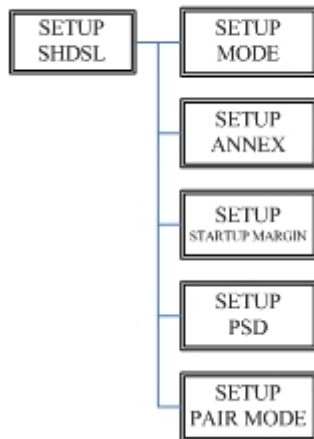

<i>SETUP SHDSL</i>	<i>Selection items</i>
SETUP MODE	STU-R, STU-C-INTCLK, STU-C-EXTCLK
SETUP ANNEX	A, B, F, G
SETUP STARTUP MARGIN	-10 to 21
SETUP PSD	SYM, ASYM
SETUP PAIR MODE	1 Pair, 2 Pair

The following are commonly used acronyms for SETUP MODE:

STU-R	RT side, where the clock source is set to external
STU-C-INTCLK	CO side, where the clock source is set to internal
STU-C-EXTCLK	CO side, where the clock source is set to external

3.5.2. Sub-Menu tree for SETUP E1 Interface

SYSTEM SETUP → SETUP E1

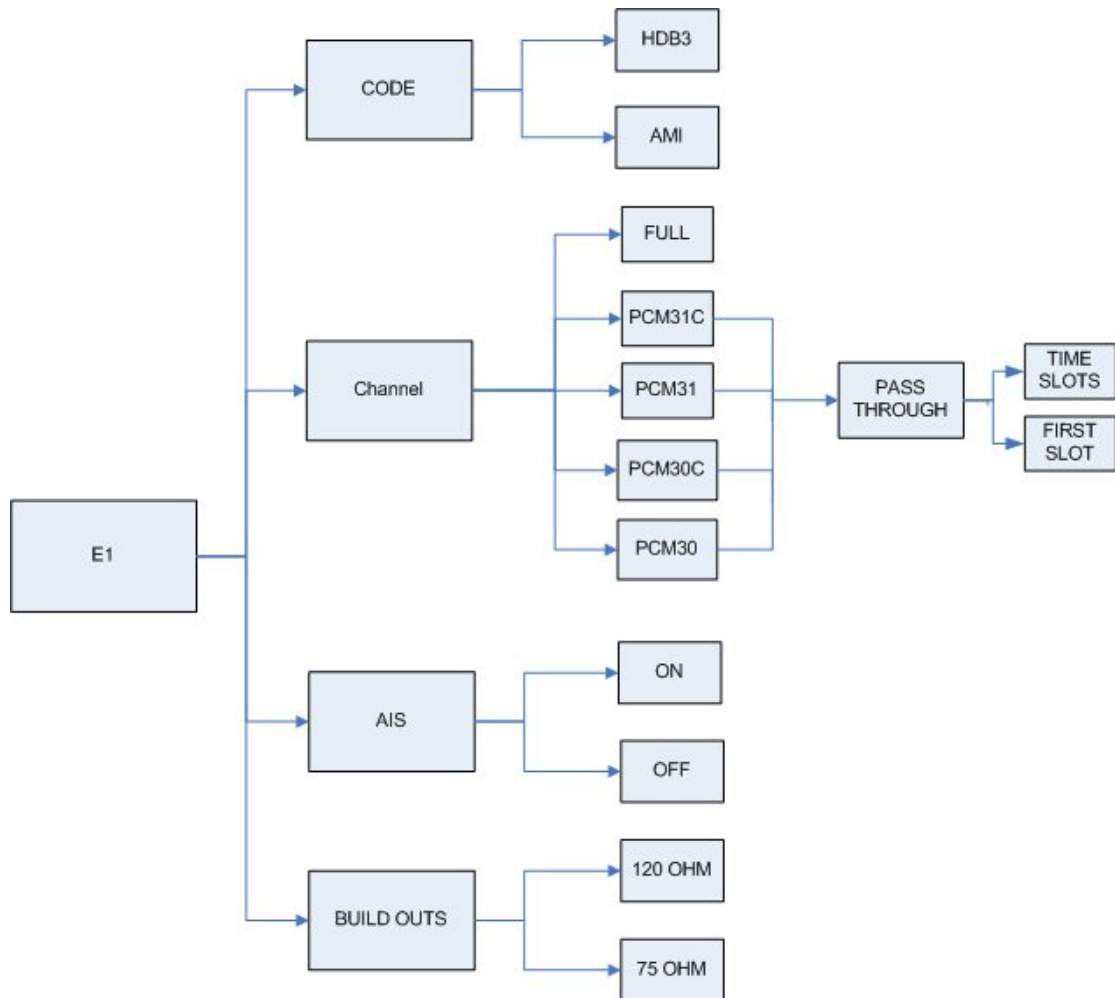

E1 parameter setting:

E1 Items	Setting
Channel	PCM31 PCM31C PCM30 PCM30C FULL
Pass Through	Off On
Code	HDB3 AMI
AIS	On Off
Build Outs	120 ohms 75 ohms

Framer Setting:

Framer		Slot Number	First Slot
PCM31	FAS	1 to 31	1 to 31
PCM31C	FAS+CRC4	1 to 31	1 to 31
PCM30	FAS+CAS	1 to 30	1 to 31 (can't use 16)
PCM30C	FAS+CAS+CRC4	1 to 30	1 to 31 (can't use 16)
FULL	UNFRAMED		

The table of number of time slot vs. 1st time slot:

Annex A/B/F/G 2-wire

Channel	Number of slot	1 st slot
FULL (UNFRAMED)	-----	-----
PCM31 PCM31C	31	1
	30	1~2
	29	1~3
	28	1~4
	27	1~5
	26	1~6
	25	1~7
	24	1~8
	23	1~9
	22	1~10
	21	1~11
	20	1~12
	19	1~13
	18	1~14
	17	1~15
	16	1~16
	15	1~17
	14	1~18
	13	1~19
	12	1~20
	11	1~21
10	1~22	
9	1~23	
8	1~24	
7	1~25	
6	1~26	
5	1~27	
4	1~28	
3	1~29	
2	1~30	
1	1~31	
PCM30 PCM30C	30	1
	29	1~2
	28	1~3
	27	1~4
	26	1~5

	25	1~6
	24	1~7
	23	1~8
	22	1~9
	21	1~10
	20	1~11
	19	1~12
	18	1~13
	17	1~14
	16	1~15
	15	1~15,17
	14	1~15,17~18
	13	1~15,17~19
	12	1~15,17~20
	11	1~15,17~21
	10	1~15,17~22
	9	1~15,17~23
	8	1~15,17~24
	7	1~15,17~25
	6	1~15,17~26
	5	1~15,17~27
	4	1~15,17~28
	3	1~15,17~29
	2	1~15,17~30
	1	1~15,17~31

Annex A/B/F/G 4-wire

Channel	Number of slot	1 st slot
FULL (UNFRAMED)	-----	-----
PCM31 PCM31C	30	1~2
	28	1~4
	26	1~6
	24	1~8
	22	1~10
	20	1~12
	18	1~14
	16	1~16
	14	1~18
	12	1~20
	10	1~22
	8	1~24
	6	1~26
	4	1~28
2	1~30	
PCM30 PCM30C	30	1
	28	1~3
	26	1~5
	24	1~7
	22	1~9
	20	1~11
18	1~13	

	16	1~15
	14	1~15,17~18
	12	1~15,17~20
	10	1~15,17~22
	8	1~15,17~24
	6	1~15,17~26
	4	1~15,17~28
	2	1~15,17~30

Note:

When SHDSL.bis uses 2-pairs(4-wires), the time slot number can only use even numbers.

When E1 framer is PCM31C or PCM30C and set pass through ON, no fractional function can be used.

3.5.3. Sub-Menu tree for SETUP SERIAL Interface

SYSTEM SETUP → SETUP SERIAL

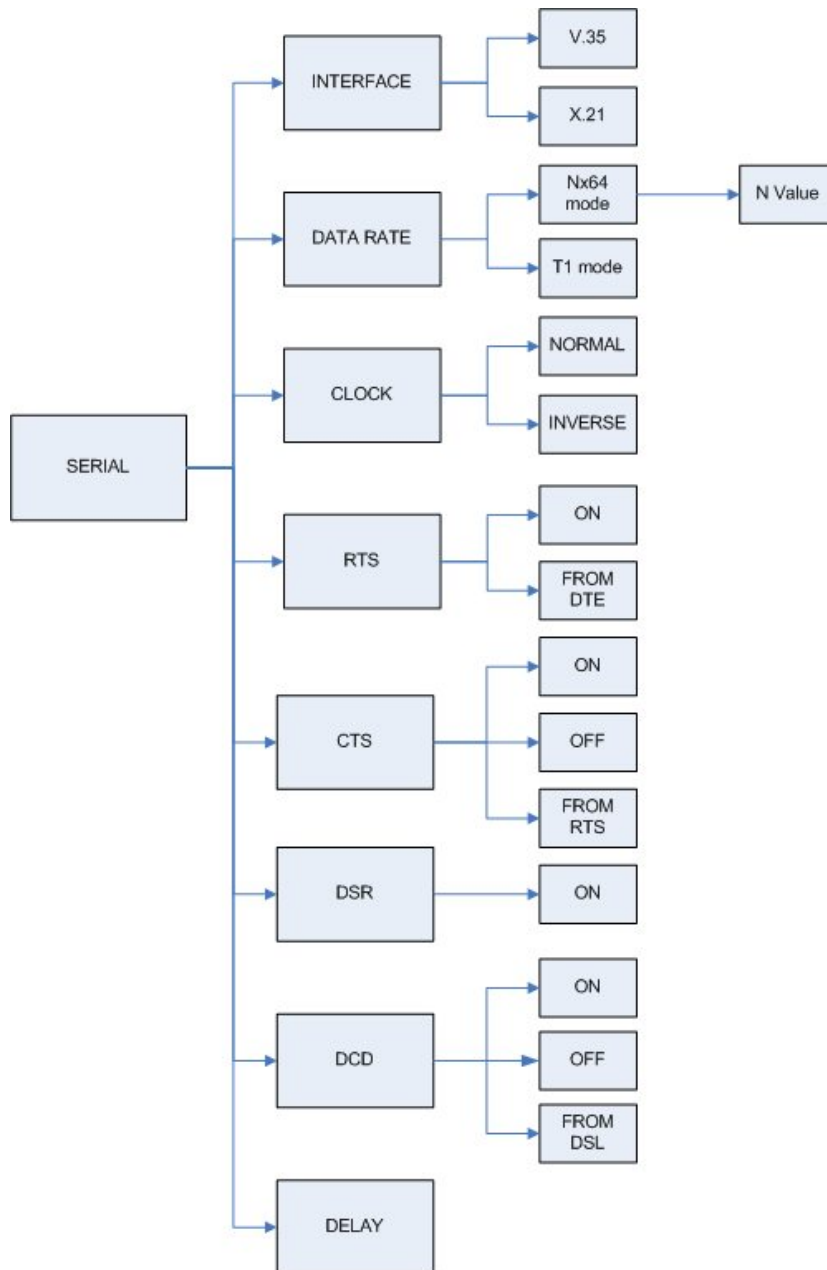

Serial interface control signals settings:

Serial Items	Setting			
INTERFACE	V.35			
	X.21(RS-530)			
Nx64K (Rate)	T1 mode			
	Nx64K mode	2-wires	Annex A/B	1 ~ 36
			Annex F/G	1 ~ 89
		4-wires	Annex A/B	2 ~ 72 (even number only)
Annex F/G			2 ~ 128 (even number only)	
CLOCK	Normal Inverse			
RTS	On From DTE			
CTS	On Off From RTS			
DSR	On Off From DTR			
DCD	On Off From DSL			
DELAY	0mS 1mS 2mS 3mS			

Note:

When SHDSL.bis uses 2-pairs (4-wires), the Nx64K(Rate) number can only use even numbers.

When other side has T1 interface and unframed mode connected to this side as Serial interface, we must set Serial rate type as T1 mode.

The handshake signal direction between DCE and DTE



The below diagram shows CTS follow RTS, DSR follow DTR

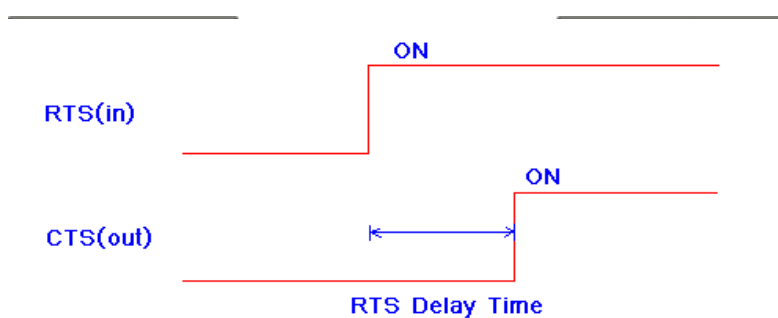

The RTS delay time is used to control CTS on delay to RTS signal, It works only for the setting: *CTS follow RTS* and *RTS follow from DTE* .

3.5.4. Sub-menu tree for SETUP Ethernet Interface

SYSTEM SETUP → SET UP ETHERNET

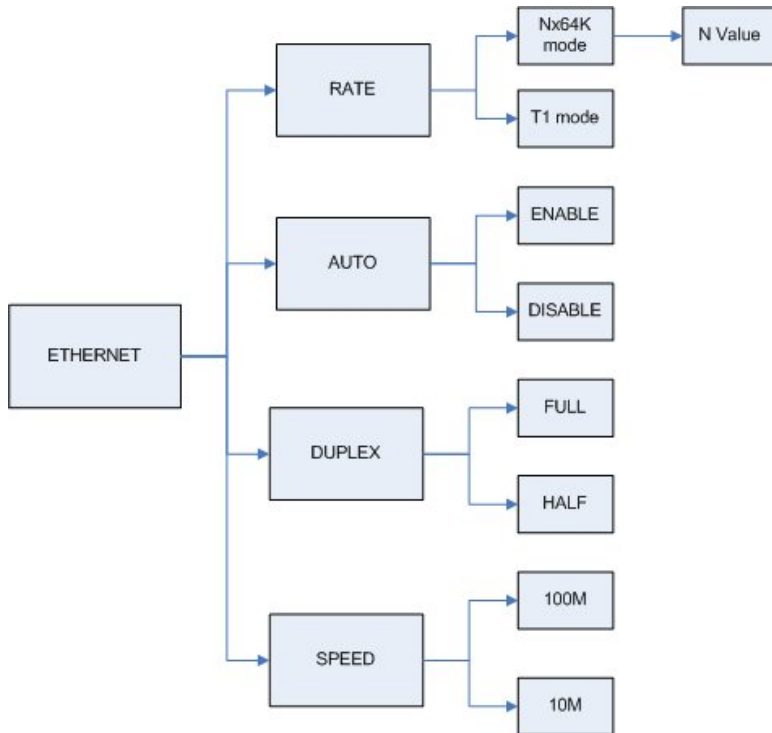

If you set Ethernet Auto Negotiation to **Enable**, the default setting for **Duplex** is **Full** and **Speed** is **100M**.

If you set Ethernet **Auto** Negotiation to **Enable**, the **Duplex** and **Speed** cannot be set up and it will use auto negotiation per IEEE802.3u.

Ethernet Items	Setting			
Rate	T1 mode			
	Nx64K mode			
	2-wires	Annex A/B	1 ~ 36	
		Annex F/G	1 ~ 89	
4-wires	Annex A/B	2 ~ 72 (even number only)		
	Annex F/G	2 ~ 178 (even number only)		
Auto	Disable	Enable		
Duplex	Full-Duplex	Auto Configuration		
Speed	100M	Auto Configuration		
	10M			

Note:

When SHDSL.bis uses 2-pairs(4-wires), the Nx64(Rate) number can only use even numbers.

When other side is T1 interface and unframed mode connects to this side as Ethernet interface, we must set Ethernet rate as T1 mode.

3.5.5. Sub-menu tree for SETUP T1 Interface

SYSTEM SETUP → SETUP T1

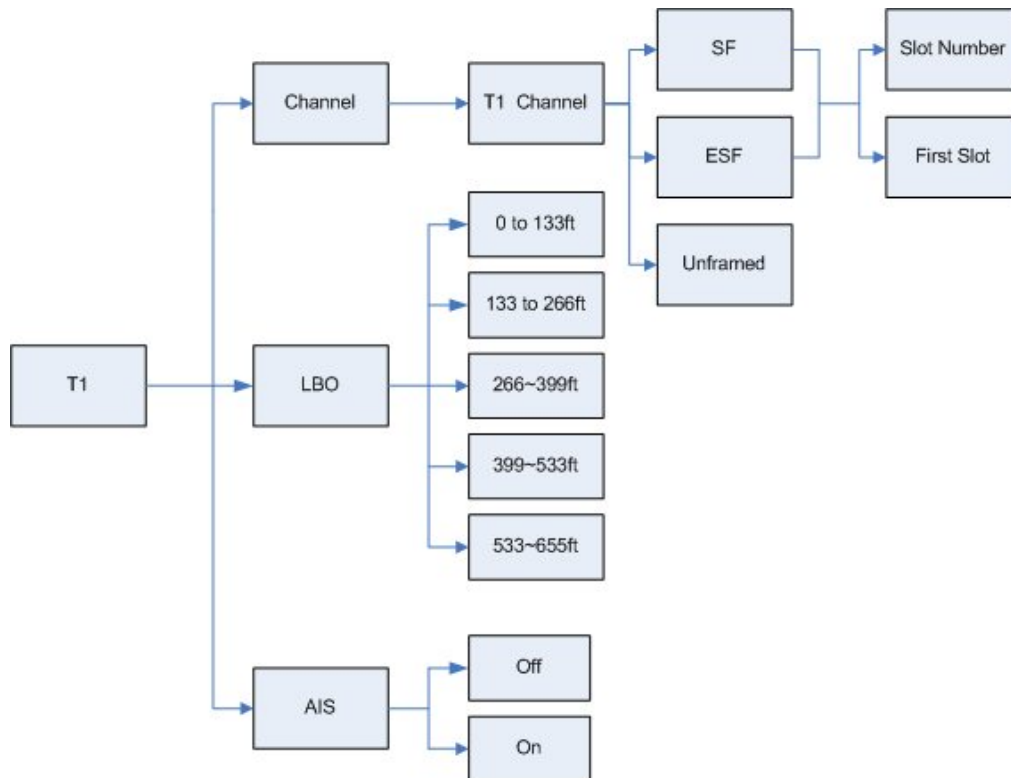

T1 parameter setting:

T1 Items	Setting
Channel	SF ESF Unframed
Slot Number	1~24
First Slot	1 to (25 -Slot Number)
LBO	0 ~133ft 133 ~ 266ft 266 ~399 ft 399 ft ~ 533ft 533ft ~ 655ft
AIS	Off On

The T1 interface can encode/decode its transmit/receive signals using Bipolar with Eight Zero Suppression (**B8ZS**) coding.

The table of number of time slot vs. 1st time slot:

Annex A/B/F/G 2-wire

Channel	Number of slot	1 st slot
SF ESF	24	1
	23	1~2
	22	1~3
	21	1~4
	20	1~5
	19	1~6
	18	1~7
	17	1~8
	16	1~9
	15	1~10
	14	1~11
	13	1~12
	12	1~13
	11	1~14
	10	1~15
	9	1~16
	8	1~17
	7	1~18
	6	1~19
	5	1~20
	4	1~21
	3	1~22
	2	1~23
	1	1~24

Annex A/B/F/G 4-wire

Channel	Number of slot	1 st slot
SF ESF	24	1
	22	1~3
	20	1~5
	18	1~7
	16	1~9
	14	1~11
	12	1~13
	10	1~15
	8	1~17
	6	1~19
	4	1~21
	2	1~23

Note:

When SHDSL.bis uses 2-pairs(4-wires), the time slot number can only use even numbers.

3.5.6. Application of STU-R configuration follow STU-C

Some configurations on STU-R side can follow STU-C side after DSL link up is finish.

Such that on STU-R side, you do not care about the settings of the E1 channel/slot number/first slot, serial data rate or Ethernet data rate. When the DSL link up is finished, these configurations will follow the STU-C side.

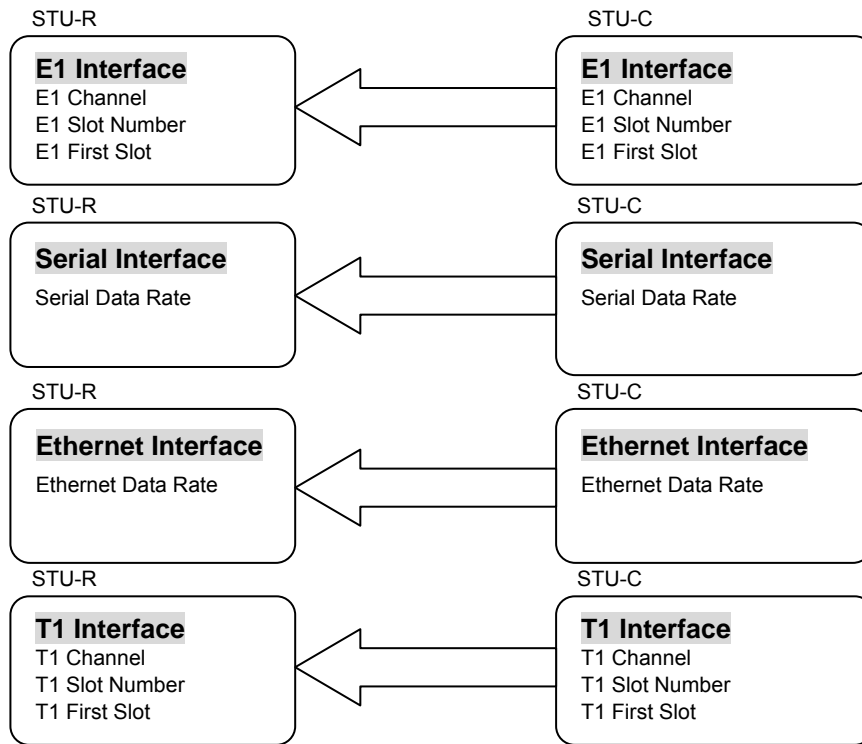

- # If STU-C is as T1 interface and set T1 channel is unframed mode, STU-R cannot follow.
- # When E1/T1 model time slot and Serial/Ethernet model data rate set 1 of 2 on STU-C side, STU-R cannot follow.
- # For the application on multi-interface, this function is not available. User must setup the configuration for both as the same time before DSL link.

Dual interface vs. Dual interface

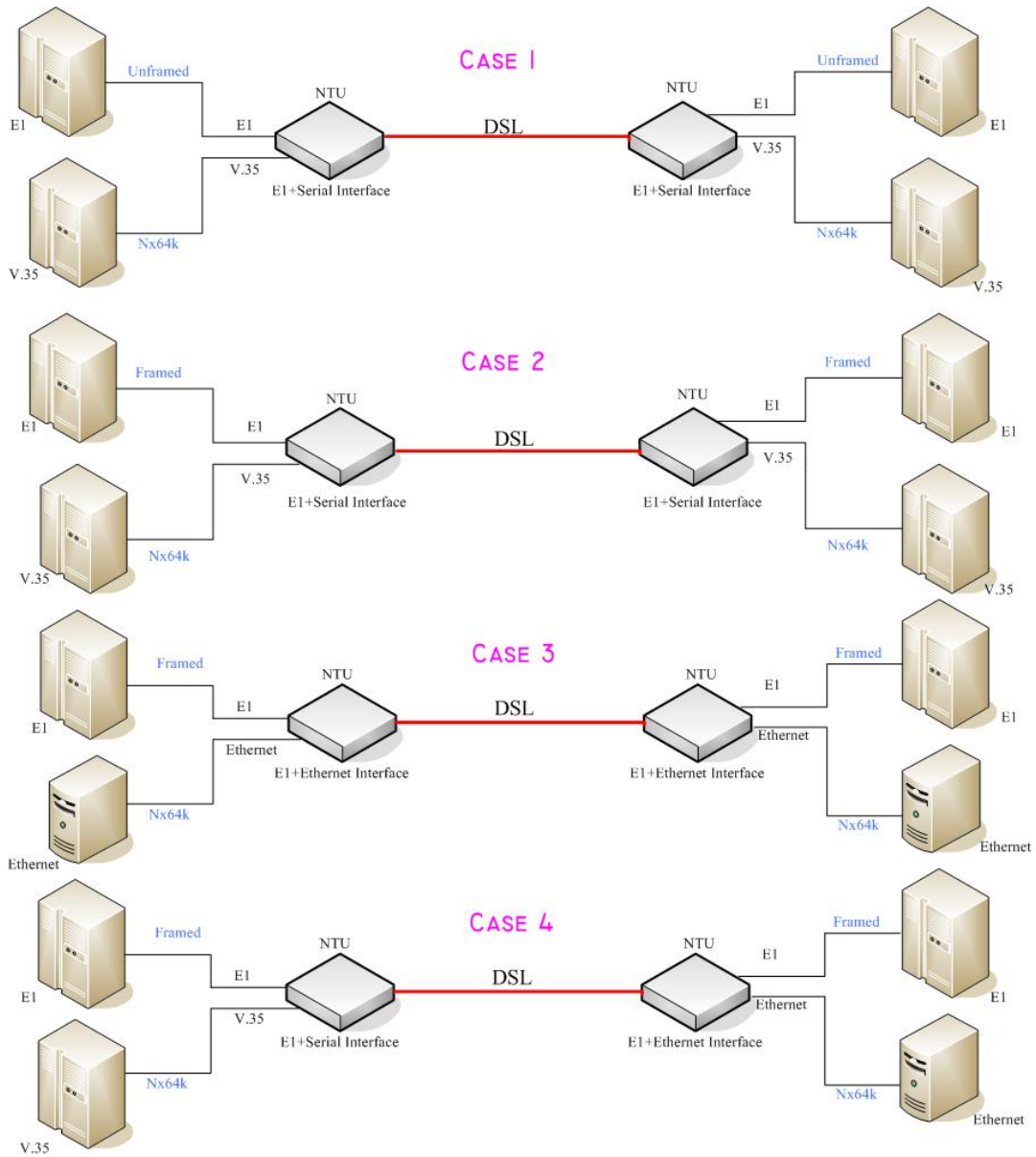

- Case 1 E1(Unframed)+ Serial interface ←-----→ E1(Unframed)+ Serial interface
- Case 2 E1(Framed)+ Serial interface ←-----→ E1(Framed)+ Serial interface
- Case 3 E1(Framed)+ Ethernet interface ←-----→ E1(Framed)+ Ethernet interface
- Case 4 E1(Framed)+ Serial interface ←-----→ E1(Framed)+ Ethernet interface

Table of E1+ Serial interface or E1+Ethernet interface mode on both sides

Annex A /B (2-wires)

E1 interface			Serial interface Ethernet interface	
Channel	Number of slot	1 st slot	Nx64K (Rate)	
FULL (UNFRAMED)	-----	-----	1~4	
PCM31 PCM31C	31	1	1~5	
	30	1	1~6	
	29	1	1~7	
	28	1	1~8	
	27	1	1~9	
	26	1	1~10	
	25	1	1~11	
	24	1	1~12	
	23	1	1~13	
	22	1	1~14	
	21	1	1~15	
	20	1	1~16	
	19	1	1~17	
	18	1	1~18	
	17	1	1~19	
	16	1	1~20	
	15	1	1~21	
	14	1	1~22	
	13	1	1~23	
	12	1	1~24	
	11	1	1~25	
	10	1	1~26	
	9	1	1~27	
	8	1	1~28	
	7	1	1~29	
	6	1	1~30	
	5	1	1~31	
	4	1	1~32	
	3	1	1~33	
	2	1	1~34	
	1	1	1~35	
	PCM30 PCM30C	30	1	1~6
		29	1	1~7
		28	1	1~8
		27	1	1~9
26		1	1~10	
25		1	1~11	
24		1	1~12	
23		1	1~13	
22		1	1~14	
21		1	1~15	
20		1	1~16	
19	1	1~17		
18	1	1~18		
17	1	1~19		

	16	1	1~20
	15	1	1~21
	14	1	1~22
	13	1	1~23
	12	1	1~24
	11	1	1~25
	10	1	1~26
	9	1	1~27
	8	1	1~28
	7	1	1~29
	6	1	1~30
	5	1	1~31
	4	1	1~32
	3	1	1~33
	2	1	1~34
	1	1	1~35

Annex F/G (2-wire)

E1 interface			Serial interface Ethernet interface
Channel	Number of slot	1 st slot	Nx64K (Rate)
FULL (UNFRAMED)	----	----	1~57
PCM31 PCM31C	31	1	1~58
	30	1	1~59
	29	1	1~60
	28	1	1~61
	27	1	1~62
	26	1	1~63
	25	1	1~64
	24	1	1~65
	23	1	1~66
	22	1	1~67
	21	1	1~68
	20	1	1~69
	19	1	1~70
	18	1	1~71
	17	1	1~72
	16	1	1~73
	15	1	1~74
	14	1	1~75
	13	1	1~76
	12	1	1~77
	11	1	1~78
	10	1	1~79
	9	1	1~80
	8	1	1~81
	7	1	1~82
	6	1	1~83
	5	1	1~84
	4	1	1~85
3	1	1~86	
2	1	1~87	
1	1	1~88	

PCM30 PCM30C	30	1	1~59
	29	1	1~60
	28	1	1~61
	27	1	1~62
	26	1	1~63
	25	1	1~64
	24	1	1~65
	23	1	1~66
	22	1	1~67
	21	1	1~68
	20	1	1~69
	19	1	1~70
	18	1	1~71
	17	1	1~72
	16	1	1~73
	15	1	1~74
	14	1	1~75
	13	1	1~76
	12	1	1~77
	11	1	1~78
	10	1	1~79
	9	1	1~80
	8	1	1~81
	7	1	1~82
	6	1	1~83
	5	1	1~84
	4	1	1~85
	3	1	1~86
2	1	1~87	
1	1	1~88	

Annex A /B (4-wires)

E1 interface			Serial interface Ethernet interface
Channel	Number of slot	1 st slot	Nx64K (Rate)
FULL (UNFRAMED)	-----	-----	1~40
PCM31 PCM31C	30	1	1~42
	28	1	1~44
	26	1	1~46
	24	1	1~48
	22	1	1~50
	20	1	1~52
	18	1	1~54
	16	1	1~56
	14	1	1~58
	12	1	1~60
	10	1	1~62
	8	1	1~64
	6	1	1~66
	4	1	1~68
2	1	1~70	
PCM30 PCM30C	30	1	1~42
	28	1	1~44

	26	1	1~46
	24	1	1~48
	22	1	1~50
	20	1	1~52
	18	1	1~54
	16	1	1~56
	14	1	1~58
	12	1	1~60
	10	1	1~62
	8	1	1~64
	6	1	1~66
	4	1	1~68
	2	1	1~70

Annex F/G (4-wire)

E1 interface			Serial interface
			Ethernet interface
Channel	Number of slot	1 st slot	Nx64K (Rate)
FULL (UNFRAMED)	-----	-----	1~96
PCM31 PCM31C	30	1	1~98
	28	1	1~100
	26	1	1~102
	24	1	1~104
	22	1	1~106
	20	1	1~108
	18	1	1~110
	16	1	1~112
	14	1	1~114
	12	1	1~116
	10	1	1~118
	8	1	1~120
	6	1	1~122
	4	1	1~124
2	1	1~126	
PCM30 PCM30C	30	1	1~98
	28	1	1~100
	26	1	1~102
	24	1	1~104
	22	1	1~106
	20	1	1~108
	18	1	1~110
	16	1	1~112
	14	1	1~114
	12	1	1~116
	10	1	1~118
	8	1	1~120
	6	1	1~122
	4	1	1~124
2	1	1~126	

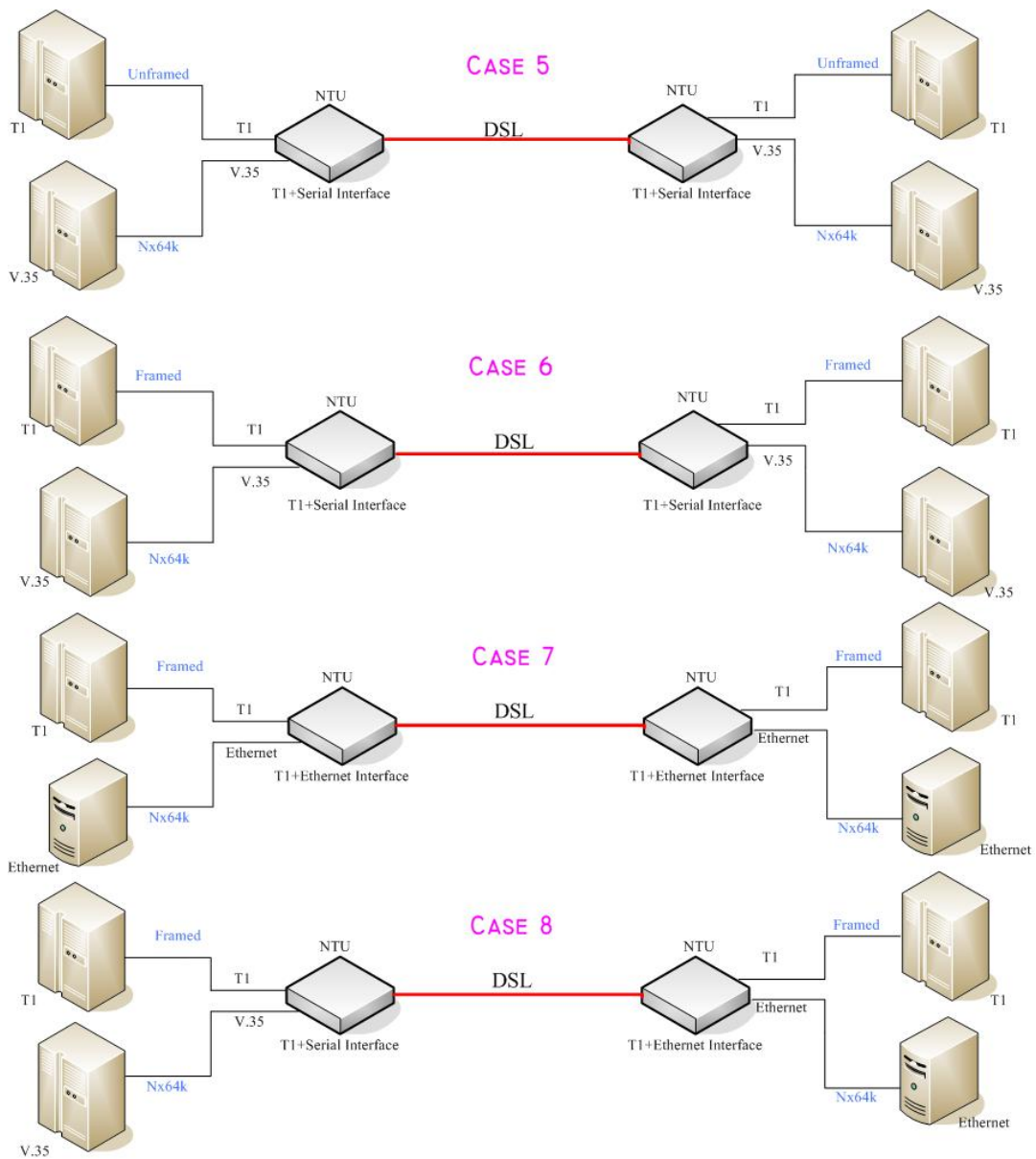

Case 5 T1(Unframed)+ Serial interface ←-----→ T1(Unframed)+ Serial interface

Case 6 T1(Framed)+ Serial interface ←-----→ T1(Framed)+ Serial interface

Case 7 T1(Framed)+ Ethernet interface ←-----→ T1(Framed)+ Ethernet interface

Case 8 T1(Framed)+ Serial interface ←-----→ T1(Framed)+ Ethernet interface

Table of T1+ Serial interface or T1+Ethernet interface mode on both sides

Annex A/B (2-wire)

T1 interface			Serial interface Ethernet interface
Channel	Number of slot	1 st slot location	Nx64K (Rate) range
Unframed	--	--	1~12
SF ESF	23	1	1~13
	22	1	1~14
	21	1	1~15
	20	1	1~16
	19	1	1~17
	18	1	1~18
	17	1	1~19
	16	1	1~20
	15	1	1~21
	14	1	1~22
	13	1	1~23
	12	1	1~24
	11	1	1~25
	10	1	1~26
	9	1	1~27
	8	1	1~28
	7	1	1~29
	6	1	1~30
	5	1	1~31
	4	1	1~32
	3	1	1~33
	2	1	1~34
	1	1	1~35

Annex G/F (2-wire)

T1 interface			Serial interface Ethernet interface
Channel	Number of slot	1 st slot location	Nx64K (Rate) range
SF ESF	24	1	1~65
	23	1	1~66
	22	1	1~67
	21	1	1~68
	20	1	1~69
	19	1	1~70
	18	1	1~71
	17	1	1~72
	16	1	1~73
	15	1	1~74
	14	1	1~75
	13	1	1~76
	12	1	1~77
	11	1	1~78
	10	1	1~79
	9	1	1~80
8	1	1~81	
7	1	1~82	

	6	1	1~83
	5	1	1~84
	4	1	1~85
	3	1	1~86
	2	1	1~87
	1	1	1~88

Annex A/B (4-wire)

T1 interface			Serial interface Ethernet interface
Channel	Number of slot	1 st slot location	Nx64K (Rate) range
Unframed	--	--	1~48
SF ESF	24	1	1~48
	22	1	1~50
	20	1	1~52
	18	1	1~54
	16	1	1~56
	14	1	1~58
	12	1	1~60
	10	1	1~62
	8	1	1~64
	6	1	1~66
	4	1	1~68
	2	1	1~70

Annex G/F (4-wire)

T1 interface			Serial interface Ethernet interface
Channel	Number of slot	1 st slot location	Nx64K (Rate) range
Unframed	--	--	1~104
SF ESF	24	1	1~104
	22	1	1~106
	20	1	1~108
	18	1	1~110
	16	1	1~112
	14	1	1~114
	12	1	1~116
	10	1	1~118
	8	1	1~120
	6	1	1~122
	4	1	1~124
	2	1	1~126

Dual interface vs. Single interface

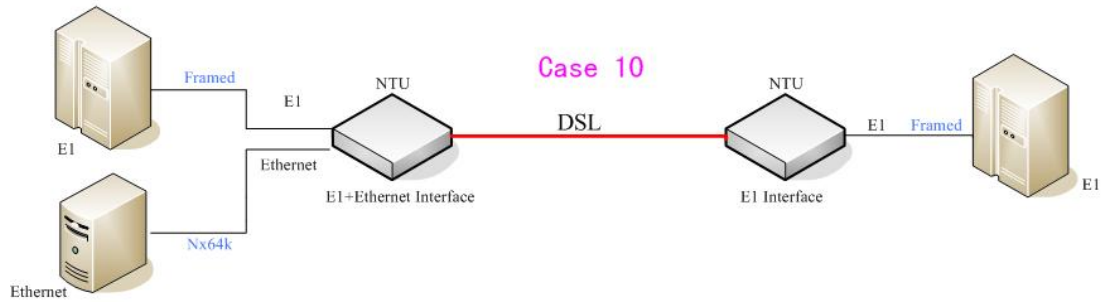
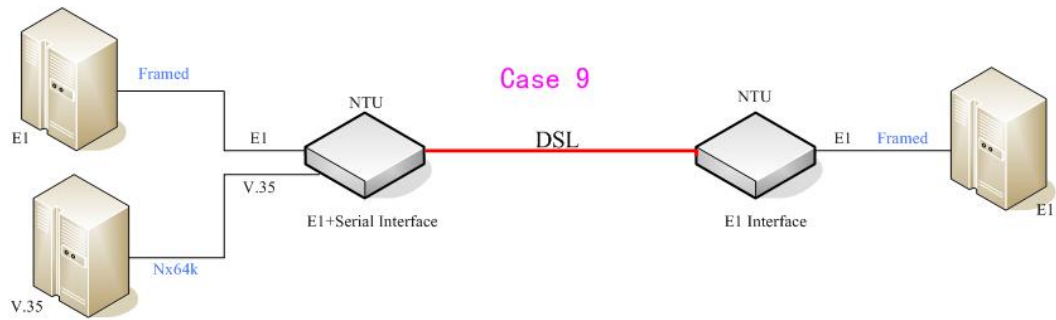

Case 9 E1(framed)+ Serial interface ←-----→ E1(framed)

Case 10 E1(framed)+Ethernet interface ←-----→ E1(framed)

Table of E1+ Serial interface to E1 interface and E1+Ethernet interface to E1 interface mode on both sides

Annex A /B/F/G (2-wires)

E1 interface			Serial interface Ethernet interface
Channel	Number of slot	1 st slot	Nx64K (Rate)
PCM31 PCM31C	30	1	1
	29	1	1~2
	28	1	1~3
	27	1	1~4
	26	1	1~5
	25	1	1~6
	24	1	1~7
	23	1	1~8
	22	1	1~9
	21	1	1~10
	20	1	1~11
	19	1	1~12
	18	1	1~13
	17	1	1~14
	16	1	1~15
	15	1	1~16
	14	1	1~17
	13	1	1~18
	12	1	1~19
	11	1	1~20
	10	1	1~21
	9	1	1~22
	8	1	1~23
	7	1	1~24
	6	1	1~25
	5	1	1~26
	4	1	1~27
	3	1	1~28
	2	1	1~29
	1	1	1~30
PCM30 PCM30C	29	1	1
	28	1	1~2
	27	1	1~3
	26	1	1~4
	25	1	1~5
	24	1	1~6
	23	1	1~7
	22	1	1~8
	21	1	1~9
	20	1	1~10
	19	1	1~11
	18	1	1~12
	17	1	1~13
16	1	1~14	
15	1	1~15	
14	1	1~16	

	13	1	1~17
	12	1	1~18
	11	1	1~19
	10	1	1~20
	9	1	1~21
	8	1	1~22
	7	1	1~23
	6	1	1~24
	5	1	1~25
	4	1	1~26
	3	1	1~27
	2	1	1~28
	1	1	1~29

Annex A /B/F/G (4-wires)

E1 interface		Serial interface	
Channel	Number of slot	1 st slot	Ethernet interface Nx64K (Rate)
PCM31 PCM31C	29	1	1
	28	1	2
	27	1	1,3
	26	1	2,4
	25	1	1,3,5
	24	1	2,4,6
	23	1	1,3,5,7
	22	1	2,4,6,8
	21	1	1,3,5,7,9
	20	1	2,4,6,8,10
	19	1	1,3,5,7,9,11
	18	1	2,4,6,8,10,12
	17	1	1,3,5,7,9,11,13
	16	1	2,4,6,8,10,12,14
	15	1	1,3,5,7,9,11,13,15
	14	1	2,4,6,8,10,12,14,16
	13	1	1,3,5,7,9,11,13,15,17
	12	1	2,4,6,8,10,12,14,16,18
	11	1	1,3,5,7,9,11,13,15,17,19
	10	1	2,4,6,8,10,12,14,16,18,20
9	1	1,3,5,7,9,11,13,15,17,19,21	
8	1	2,4,6,8,10,12,14,16,18,20,22	
7	1	1,3,5,7,9,11,13,15,17,19,21,23	
6	1	2,4,6,8,10,12,14,16,18,20,22,24	
5	1	1,3,5,7,9,11,13,15,17,19,21,23,25	
4	1	2,4,6,8,10,12,14,16,18,20,22,24,26	
3	1	1,3,5,7,9,11,13,15,17,19,21,23,25,27	
2	1	2,4,6,8,10,12,14,16,18,20,22,24,26,28	
1	1	1,3,5,7,9,11,13,15,17,19,21,23,25,27,29	
PCM30 PCM30C	29	1	1
	28	1	2
	27	1	1,3
	26	1	2,4
	25	1	1,3,5

24	1	2,4,6
23	1	1,3,5,7
22	1	2,4,6,8
21	1	1,3,5,7,9
20	1	2,4,6,8,10
19	1	1,3,5,7,9,11
18	1	2,4,6,8,10,12
17	1	1,3,5,7,9,11,13
16	1	2,4,6,8,10,12,14
15	1	1,3,5,7,9,11,13,15
14	1	2,4,6,8,10,12,14,16
13	1	1,3,5,7,9,11,13,15,17
12	1	2,4,6,8,10,12,14,16,18
11	1	1,3,5,7,9,11,13,15,17,19
10	1	2,4,6,8,10,12,14,16,18,20
9	1	1,3,5,7,9,11,13,15,17,19,21
8	1	2,4,6,8,10,12,14,16,18,20,22
7	1	1,3,5,7,9,11,13,15,17,19,21,23
6	1	2,4,6,8,10,12,14,16,18,20,22,24
5	1	1,3,5,7,9,11,13,15,17,19,21,23,25
4	1	2,4,6,8,10,12,14,16,18,20,22,24,26
3	1	1,3,5,7,9,11,13,15,17,19,21,23,25,27
2	1	2,4,6,8,10,12,14,16,18,20,22,24,26,28
1	1	1,3,5,7,9,11,13,15,17,19,21,23,25,27,29

Note: the E1 first time slot should be 1

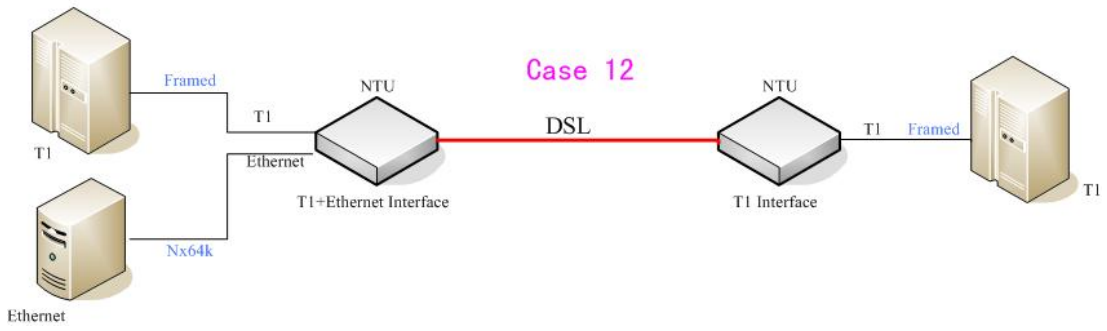
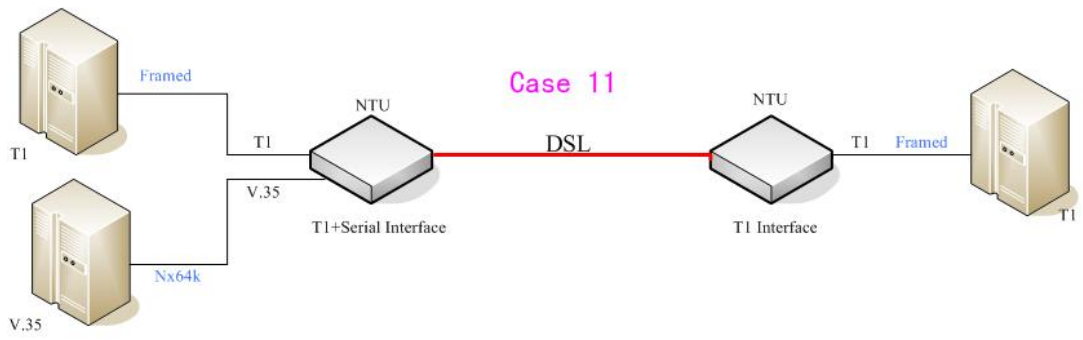

Case 11 T1(framed)+ Serial interface <-----> T1(framed)

Case 12 T1(framed)+Ethernet interface <-----> T1(framed)

Table of T1+ Serial interface to T1 interface and T1+Ethernet interface to T1 interface mode on both sides

Annex A /B/F/G (2-wires)

E1 interface			Serial interface Ethernet interface
Channel	Number of slot	1 st slot	Nx64K (Rate)
SF	23	1	1
ESF	22	1	1~2
	21	1	1~3
	20	1	1~4
	19	1	1~5
	18	1	1~6
	17	1	1~7
	16	1	1~8
	15	1	1~9
	14	1	1~10
	13	1	1~11
	12	1	1~12
	11	1	1~13
	10	1	1~14
	9	1	1~15
	8	1	1~16
	7	1	1~17
	6	1	1~18
	5	1	1~19
	4	1	1~20
	3	1	1~21
	2	1	1~22
	1	1	1~23

Note: the T1 first time slot should be 1

Annex A /B/F/G (4-wires)

T1 interface			Serial interface Ethernet interface
Channel	Number of slot	1 st slot	Nx64K (Rate)
SF	23	1	1
ESF	22	1	2
	21	1	1,3
	20	1	2,4
	19	1	1,3,5
	18	1	2,4,6
	17	1	1,3,5,7
	16	1	2,4,6,8
	15	1	1,3,5,7,9
	14	1	2,4,6,8,10
	13	1	1,3,5,7,9,11
	12	1	2,4,6,8,10,12
	11	1	1,3,5,7,9,11,13
	10	1	2,4,6,8,10,12,14
	9	1	1,3,5,7,9,11,13,15
	8	1	2,4,6,8,10,12,14,16

	7	1	1,3,5,7,9,11,13,15,17
	6	1	2,4,6,8,10,12,14,16,18
	5	1	1,3,5,7,9,11,13,15,17,19
	4	1	2,4,6,8,10,12,14,16,18,20
	3	1	1,3,5,7,9,11,13,15,17,19,21
	2	1	2,4,6,8,10,12,14,16,18,20,24
	1	1	1,3,5,7,9,11,13,15,17,19,21,23

Note: the T1 first time slot should be 1

3.6 Sub-menu tree for REBOOT SYSTEM

REBOOT SYSTEM -> * REBOOT * YES -> press "ENTER" key

Some settings request system reboot for the setting to take effect.

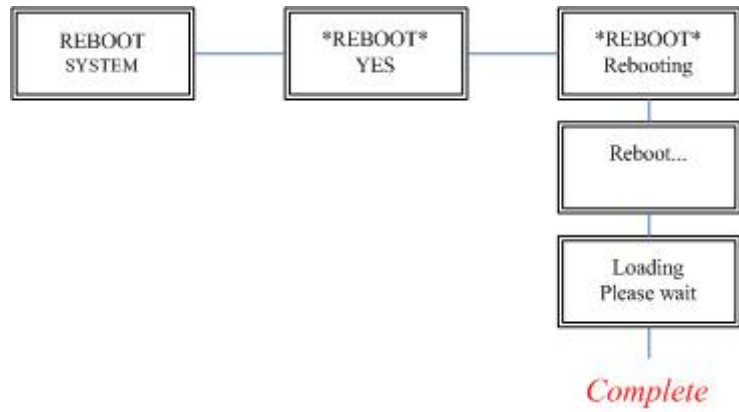

3.7 Sub-Menu tree for DIAGNOSTIC

3.7.1. Loopback function

SYSTEM DIAGNOSTIC → DIAG LOOPBACK

Note : there is no SYSTEM DIAGNOSTIC menu on the Ethernet Interface Model

If the device hasn't connected or it is under handshake, it will not support farend line, farend payload and V.54.

Stand alone NTU, no connection with other NTU:

E1/T1 interface
CO side
Local digital
Local
Remote line
Remote payload

Serial interface
CO side
Local digital
Local
Remote line
Remote payload

E1 /T1interface
CPE side
Local digital
Remote line
Remote payload

Serial interface
CPE side
Local digital
Remote line
Remote payload

After connection both CO side and CPE side:

E1/T1 interface
CO side
Local digital
Local
Remote line
Remote payload
Farend line
Farend payload

Serial interface
CO side
Local digital
Local
Remote line
Remote payload
Farend line
Farend payload
V.54

E1/T1 interface
CPE side
Local digital
Remote line
Remote payload
Farend line
Farend payload

Serial interface
CPE side
Local digital
Remote line
Remote payload
Farend line
Farend payload
V.54

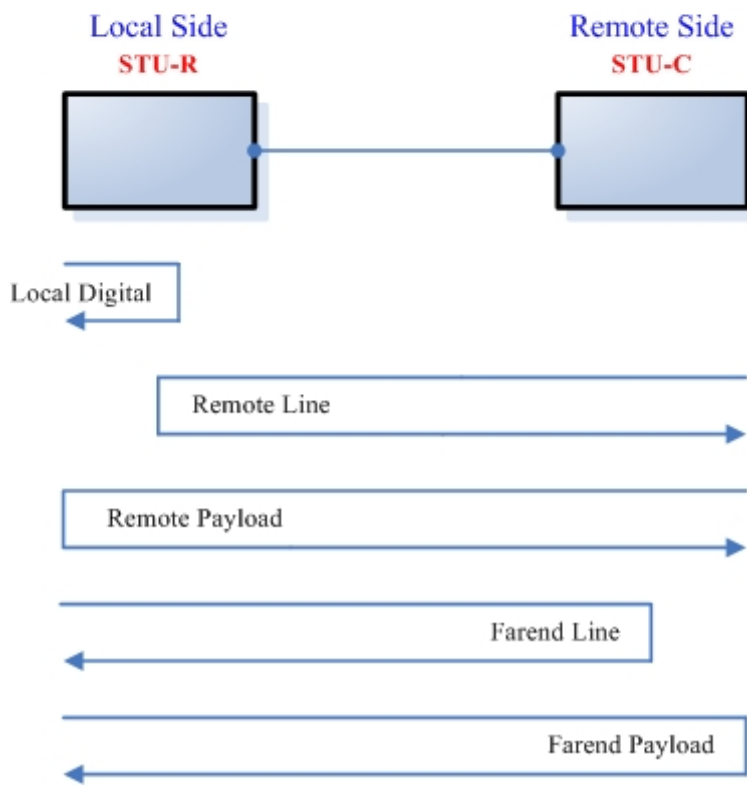
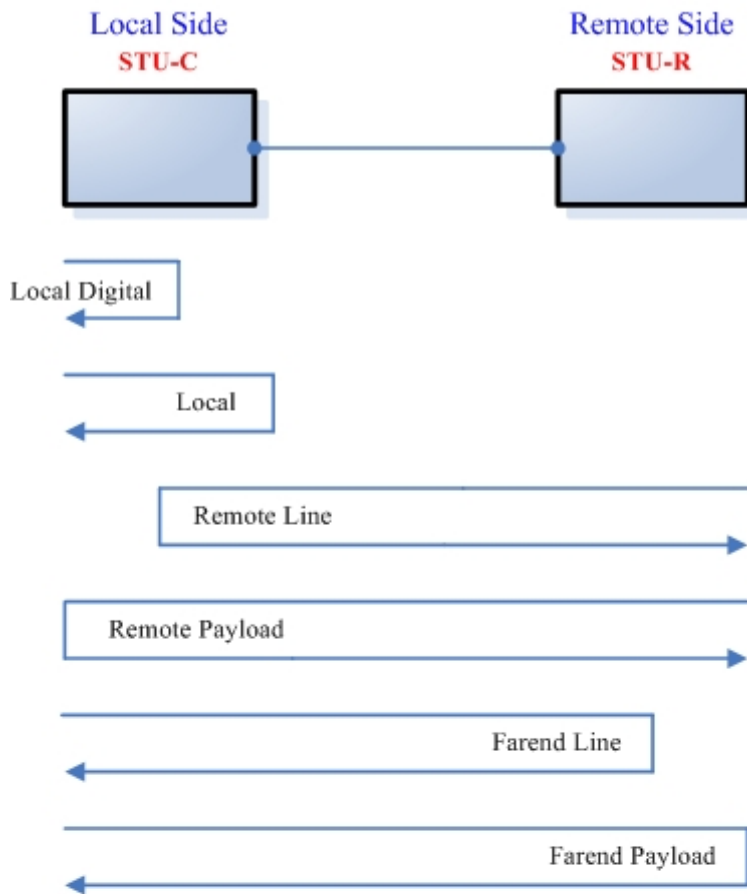

E1 Interface

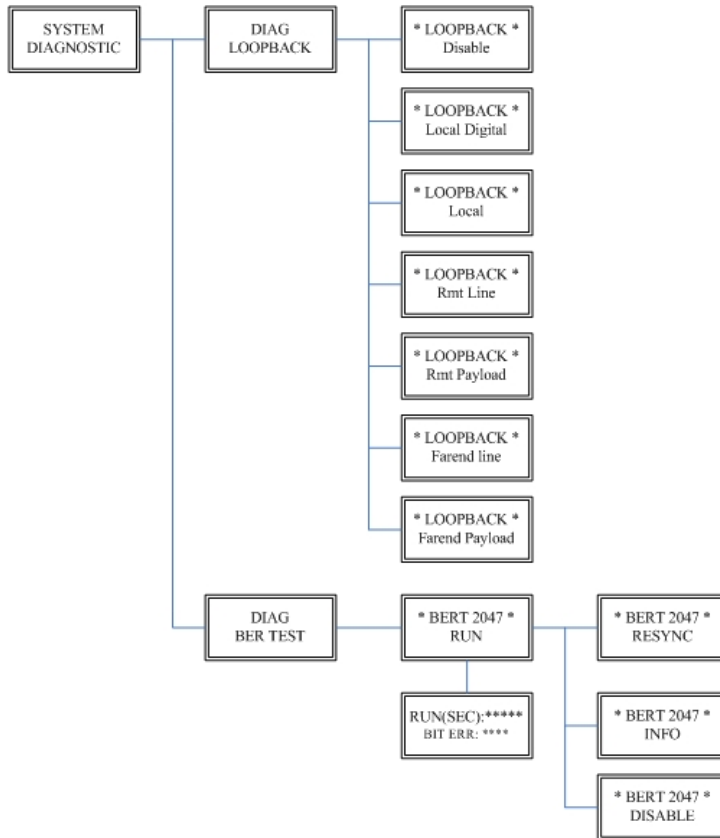

Serial Interface

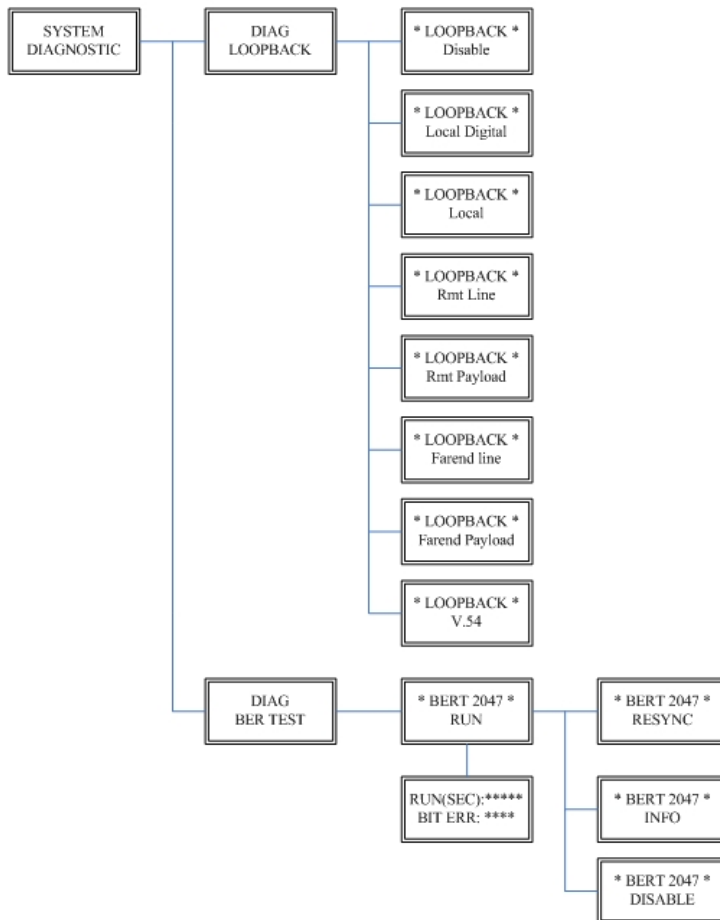

3.7.2. BER Test function

SYSTEM DIAGNOSTIC → DIAG BER TEST

This is the internal Bit Error Rate Tester (BERT) for complete testing of local and remote modem and the link quality without any external test equipment.

This built-in Bit Error Rate Test generator can generate a standard 2047 ($2^{11}-1$) test pattern.

```
DIAG
BER TEST
```

```
*BERT 2047*
RUN
```

When the BERT doesn't have Bit Errors, it shows zero. Otherwise, it will show some number counter.

RUN(SEC) item shows the time elapsed in seconds

```
RUN(SEC): 00001
BIT ERR: 00000
```

If there is NO SYNC on bit error message, it is because the testing path hasn't been connected.

```
RUN(SEC): 00001
BIT ERR: NO SYNC
```

Press ENTER key on this display message, it will re-sync again.

```
*BERT 2047*
RESYNC
```

Press ENTER key on this display message, it will show the real time status of this testing.

```
*BERT 2047*
INFO
```

If you want to exit the BERT, please press ENTER key from this display message.

```
*BERT 2047*
DISABLE
```

4. Parameters Table

There are many parameters tables for end user easily to write down all setting of devices before installing those on sites.

4.1 SHDTU03b-E1

4.1.1. SHDTU03b-E1I -- E1 interface mode

NTU	Type	<input type="checkbox"/> STU-R <input type="checkbox"/> STU-C-INTCLK <input type="checkbox"/> STU-C-EXTCLK
SHDSL	Annex	<input type="checkbox"/> A <input type="checkbox"/> B <input type="checkbox"/> F <input type="checkbox"/> G
	PSD	<input type="checkbox"/> SYM <input type="checkbox"/> ASYM
	SNR Margin	(-10~21)
	Pair Mode	<input type="checkbox"/> 1 Pair <input type="checkbox"/> 2 pair (For SHDTU03bA-E1 only)
E1	Channel	<input type="checkbox"/> PCM31 <input type="checkbox"/> PCM31C <input type="checkbox"/> PCM30 <input type="checkbox"/> PCM30C <input type="checkbox"/> Unframed
	Pass Through	<input type="checkbox"/> Off <input type="checkbox"/> On
	Slot Number	
	First Slot	
	Code	<input type="checkbox"/> HDB3 <input type="checkbox"/> AMI
	AIS	<input type="checkbox"/> Off <input type="checkbox"/> On
	Build Outs	<input type="checkbox"/> 75 Ohm <input type="checkbox"/> 120 Ohm

When SHDSL.bis using 2-pairs (4-wires), the E1 time slot number can only use even number

When E1 framer is PCM31C and PCM30C and set pass through ON, no fractional function can be use.

4.1.2. SHDTU03b-E1/T1 -- T1 interface mode

T1	Channel	<input type="checkbox"/> SF <input type="checkbox"/> ESF <input type="checkbox"/> Unframed
	Slot Number	
	First Slot	
	LBO	<input type="checkbox"/> 0~133ft <input type="checkbox"/> 133~266ft <input type="checkbox"/> 266~399ft <input type="checkbox"/> 399ft~533ft <input type="checkbox"/> 533~655ft
	AIS	<input type="checkbox"/> Off <input type="checkbox"/> On

When SHDSL.bis using 2-pairs (4-wires), the T1 time slot number can only use even number

4.2 SHDTU03b-Data

4.2.1. SHDTU03b-Data -- Serial interface mode

NTU	Type	<input type="checkbox"/> STU-R	<input type="checkbox"/> STU-C-INTCLK	<input type="checkbox"/> STU-C-EXTCLK	
SHDSL	Annex	<input type="checkbox"/> A	<input type="checkbox"/> B	<input type="checkbox"/> F <input type="checkbox"/> G	
	PSD	<input type="checkbox"/> SYM <input type="checkbox"/> ASYM			
	SNR Margin	(-10~21)			
	Pair Mode	<input type="checkbox"/> 1 Pair	<input type="checkbox"/> 2 pair	(For SHDTU03bA-Data only)	
Serial	Interface	<input type="checkbox"/> V.35 <input type="checkbox"/> X.21			
	Data Rate	<input type="checkbox"/> Nx64K <input type="checkbox"/> T1 mode			
		1 Pair	Annex A/B	(1~36)	
			Annex F/G	(1~89)	
		2 Pair	Annex A/B	(2~72)	
	Annex F/G		(2~128)		
	Clock	<input type="checkbox"/> Normal <input type="checkbox"/> Inverse			
	RTS	<input type="checkbox"/> On <input type="checkbox"/> From DTE			
	CTS	<input type="checkbox"/> On <input type="checkbox"/> Off <input type="checkbox"/> From RTS			
	DSR	<input type="checkbox"/> On <input type="checkbox"/> Off <input type="checkbox"/> From DTR			
	DCD	<input type="checkbox"/> On <input type="checkbox"/> Off <input type="checkbox"/> From DSL			
Delay	<input type="checkbox"/> 0mS <input type="checkbox"/> 1mS <input type="checkbox"/> 2mS <input type="checkbox"/> 3mS				

When SHDSL.bis using 2-pairs (4-wires), the Serial Nx64K data rate number can only use even number

4.3 SHDTU03b-ET100

4.3.1. SHDTU03b-ET100 -- Ethernet interface mode

NTU	Type	<input type="checkbox"/> STU-R <input type="checkbox"/> STU-C-INTCLK <input type="checkbox"/> STU-C-EXTCLK		
SHDSL	Annex	<input type="checkbox"/> A <input type="checkbox"/> B <input type="checkbox"/> F <input type="checkbox"/> G		
	PSD	<input type="checkbox"/> SYM <input type="checkbox"/> ASYM		
	SNR Margin	(-10~21)		
	Pair Mode	<input type="checkbox"/> 1 Pair <input type="checkbox"/> 2 pair (For SHDTU03bA-ET100 only)		
Ethernet	Date Rate	<input type="checkbox"/> Nx64K <input type="checkbox"/> T1 mode		
		1 Pair	Annex A/B	(1~36)
			Annex F/G	(1~89)
		2 Pair	Annex A/B	(2~72)
			Annex F/G	(2~178)
		Auto Config	<input type="checkbox"/> Disable <input type="checkbox"/> Enable	
	Duplex	<input type="checkbox"/> Full <input type="checkbox"/> Half		
	Speed	<input type="checkbox"/> 100M <input type="checkbox"/> 10M		

When SHDSL.bis using 2-pairs (4-wires), the Ethernet Nx64K data rate number can only use even number

4.4 SHDTU03b-31

4.4.1. SHDTU03b-31 -- E1 Interface mode

NTU	Interface	<input type="checkbox"/> E1 <input type="checkbox"/> Serial <input type="checkbox"/> Ethernet <input type="checkbox"/> E1+Serial <input type="checkbox"/> E1+Ethernet
	Type	<input type="checkbox"/> STU-R <input type="checkbox"/> STU-C-INTCLK <input type="checkbox"/> STU-C-EXTCLK
SHDSL	Annex	<input type="checkbox"/> A <input type="checkbox"/> B <input type="checkbox"/> F <input type="checkbox"/> G
	PSD	<input type="checkbox"/> SYM <input type="checkbox"/> ASYM
	SNR Margin	(-10~21)
	Pair Mode	<input type="checkbox"/> 1 Pair <input type="checkbox"/> 2 pair (For SHDTU03bA-31 only)
E1	Channel	<input type="checkbox"/> CM31 <input type="checkbox"/> PCM31C <input type="checkbox"/> PCM30 <input type="checkbox"/> PCM30C <input type="checkbox"/> Unframed
	Pass Through	<input type="checkbox"/> Off <input type="checkbox"/> On
	Slot Number	
	First Slot	
	Code	<input type="checkbox"/> HDB3 <input type="checkbox"/> AMI
	AIS	<input type="checkbox"/> Off <input type="checkbox"/> On
	Build Outs	<input type="checkbox"/> 75 Ohm <input type="checkbox"/> 120 Ohm

When SHDSL.bis using 2-pairs (4-wires), the E1 time slot number can only use even number

When E1 framer is PCM31C and PCM30C and set pass through ON, no fractional function can be use.

4.4.2. SHDTU03b-31 -- Serial Interface mode

NTU	Interface	<input type="checkbox"/> E1 <input type="checkbox"/> Serial <input type="checkbox"/> Ethernet <input type="checkbox"/> E1+Serial <input type="checkbox"/> E1+Ethernet		
	Type	<input type="checkbox"/> STU-R <input type="checkbox"/> STU-C-INTCLK <input type="checkbox"/> STU-C-EXTCLK		
SHDSL	Annex	<input type="checkbox"/> A <input type="checkbox"/> B <input type="checkbox"/> F <input type="checkbox"/> G		
	PSD	<input type="checkbox"/> SYM <input type="checkbox"/> ASYM		
	SNR Margin	(-10~21)		
	Pair Mode	<input type="checkbox"/> 1 Pair <input type="checkbox"/> 2 pair (For SHDTU03bA-31 only)		
Serial	Interface	<input type="checkbox"/> V.35 <input type="checkbox"/> X.21		
	Data Rate	<input type="checkbox"/> Nx64K <input type="checkbox"/> T1 mode		
		1 Pair	Annex A/B	(1~36)
			Annex F/G	(1~89)
		2 Pair	Annex A/B	(2~72)
			Annex F/G	(2~128)
	Clock	<input type="checkbox"/> Normal <input type="checkbox"/> Inverse		
	RTS	<input type="checkbox"/> On <input type="checkbox"/> From DTE		
	CTS	<input type="checkbox"/> On <input type="checkbox"/> Off <input type="checkbox"/> From RTS		
	DSR	<input type="checkbox"/> On <input type="checkbox"/> Off <input type="checkbox"/> From DTR		
DCD	<input type="checkbox"/> On <input type="checkbox"/> Off <input type="checkbox"/> From DSL			
Delay	<input type="checkbox"/> 0mS <input type="checkbox"/> 1mS <input type="checkbox"/> 2mS <input type="checkbox"/> 3mS			

When SHDSL.bis using 2-pairs (4-wires), the Serial Nx64K data rate number can only use even number

4.4.3. SHDTU03b-31 -- Ethernet Interface mode

NTU	Interface	<input type="checkbox"/> E1 <input type="checkbox"/> Serial <input type="checkbox"/> Ethernet <input type="checkbox"/> E1+Serial <input type="checkbox"/> E1+Ethernet		
	Type	<input type="checkbox"/> STU-R <input type="checkbox"/> STU-C-INTCLK <input type="checkbox"/> STU-C-EXTCLK		
SHDSL	Annex	<input type="checkbox"/> A <input type="checkbox"/> B <input type="checkbox"/> F <input type="checkbox"/> G		
	PSD	<input type="checkbox"/> SYM <input type="checkbox"/> ASYM		
	SNR Margin	(-10~21)		
	Pair Mode	<input type="checkbox"/> 1 Pair <input type="checkbox"/> 2 pair (For SHDTU03bA-31 only)		
Ethernet	Date Rate	<input type="checkbox"/> Nx64K <input type="checkbox"/> T1 mode		
		1 Pair	Annex A/B	(1~36)
			Annex F/G	(1~89)
		2 Pair	Annex A/B	(2~72)
	Annex F/G		(2~178)	
	Auto Config	<input type="checkbox"/> Disable <input type="checkbox"/> Enable		
	Duplex	<input type="checkbox"/> Full <input type="checkbox"/> Half		
Speed	<input type="checkbox"/> 100M <input type="checkbox"/> 10M			

When SHDSL.bis using 2-pairs (4-wires), the Ethernet Nx64K data rate number can only use even number

4.4.4. SHDTU03b-31 -- E1+Serial Interface mode

NTU	Interface	<input type="checkbox"/> E1 <input type="checkbox"/> Serial <input type="checkbox"/> Ethernet <input type="checkbox"/> E1+Serial <input type="checkbox"/> E1+Ethernet
	Type	<input type="checkbox"/> STU-R <input type="checkbox"/> STU-C-INTCLK <input type="checkbox"/> STU-C-EXTCLK
SHDSL	Annex	<input type="checkbox"/> A <input type="checkbox"/> B <input type="checkbox"/> F <input type="checkbox"/> G
	PSD	<input type="checkbox"/> SYM <input type="checkbox"/> ASYM
	SNR Margin	(-10~21)
	Pair Mode	<input type="checkbox"/> 1 Pair <input type="checkbox"/> 2 pair (For SHDTU03bA-31 only)
E1	Channel	<input type="checkbox"/> PCM31 <input type="checkbox"/> PCM31C <input type="checkbox"/> PCM30 <input type="checkbox"/> PCM30C <input type="checkbox"/> Unframed
	Slot Number	
	First Slot	
	Code	<input type="checkbox"/> HDB3 <input type="checkbox"/> AMI
	AIS	<input type="checkbox"/> Off <input type="checkbox"/> On
	Build Outs	<input type="checkbox"/> 75 Ohm <input type="checkbox"/> 120 Ohm
Serial	Interface	<input type="checkbox"/> V.35 <input type="checkbox"/> X.21
	Data Rate	<input type="checkbox"/> Nx64K <input type="checkbox"/> T1 mode
	Clock	<input type="checkbox"/> Normal <input type="checkbox"/> Inverse
	RTS	<input type="checkbox"/> On <input type="checkbox"/> From DTE
	CTS	<input type="checkbox"/> On <input type="checkbox"/> Off <input type="checkbox"/> From RTS
	DSR	<input type="checkbox"/> On <input type="checkbox"/> Off <input type="checkbox"/> From DTR
	DCD	<input type="checkbox"/> On <input type="checkbox"/> Off <input type="checkbox"/> From DSL
Delay	<input type="checkbox"/> 0mS <input type="checkbox"/> 1mS <input type="checkbox"/> 2mS <input type="checkbox"/> 3mS	

When SHDSL.bis using 2-pairs (4-wires), the E1 time slot number and Serial Nx64K data rate number can only use even number.

When E1 framer is PCM31C and PCM30C and set pass through ON, no fractional function can be use.

4.4.5. SHDTU03b-31 -- E1+Ethernet Interface mode

NTU	Interface	<input type="checkbox"/> E1 <input type="checkbox"/> Serial <input type="checkbox"/> Ethernet <input type="checkbox"/> E1+Serial <input type="checkbox"/> E1+Ethernet
	Type	<input type="checkbox"/> STU-R <input type="checkbox"/> STU-C-INTCLK <input type="checkbox"/> STU-C-EXTCLK
SHDSL	Annex	<input type="checkbox"/> A <input type="checkbox"/> B <input type="checkbox"/> F <input type="checkbox"/> G
	PSD	<input type="checkbox"/> SYM <input type="checkbox"/> ASYM
	SNR Margin	(-10~21)
	Pair Mode	<input type="checkbox"/> 1 Pair <input type="checkbox"/> 2 pair (For SHDTU03bA-31 only)
E1	Channel	<input type="checkbox"/> PCM31 <input type="checkbox"/> PCM31C <input type="checkbox"/> PCM30 <input type="checkbox"/> PCM30C <input type="checkbox"/> Unframed
	Slot Number	
	First Slot	
	Code	<input type="checkbox"/> HDB3 <input type="checkbox"/> AMI
	AIS	<input type="checkbox"/> Off <input type="checkbox"/> On
	Build Outs	<input type="checkbox"/> 75 Ohm <input type="checkbox"/> 120 Ohm
Ethernet	Date Rate	<input type="checkbox"/> Nx64K <input type="checkbox"/> T1 mode
	Auto Config	<input type="checkbox"/> Disable <input type="checkbox"/> Enable
	Duplex	<input type="checkbox"/> Full <input type="checkbox"/> Half
	Speed	<input type="checkbox"/> 100M <input type="checkbox"/> 10M

When SHDSL.bis using 2-pairs(4-wires), the E1 time slot number and Ethernet Nx64K data rate number can only use even number

When E1 framer is PCM31C and PCM30C and set pass through ON, no fractional function can be use.

4.5 SHDTU03b-E1/T1

4.5.1. SHDTU03b-E1/T1 -- E1 Interface mode

NTU	Interface	<input type="checkbox"/> E1 <input type="checkbox"/> T1
	Type	<input type="checkbox"/> STU-R <input type="checkbox"/> STU-C-INTCLK <input type="checkbox"/> STU-C-EXTCLK
SHDSL	Annex	<input type="checkbox"/> A <input type="checkbox"/> B <input type="checkbox"/> F <input type="checkbox"/> G
	PSD	<input type="checkbox"/> SYM <input type="checkbox"/> ASYM
	SNR Margin	(-10~21)
	Pair Mode	<input type="checkbox"/> 1 Pair <input type="checkbox"/> 2 pair (For SHDTU03bA-E1/T1 only)
E1	Channel	<input type="checkbox"/> PCM31 <input type="checkbox"/> PCM31C <input type="checkbox"/> PCM30 <input type="checkbox"/> PCM30C <input type="checkbox"/> Unframed
	Pass Through	<input type="checkbox"/> Off <input type="checkbox"/> On
	Slot Number	
	First Slot	
	Code	<input type="checkbox"/> HDB3 <input type="checkbox"/> AMI
	AIS	<input type="checkbox"/> Off <input type="checkbox"/> On
	Build Outs	<input type="checkbox"/> 75 Ohm <input type="checkbox"/> 120 Ohm
T1	Channel	<input type="checkbox"/> SF <input type="checkbox"/> ESF <input type="checkbox"/> Unframed
	Slot Number	
	First Slot	
	LBO	<input type="checkbox"/> 0~133ft <input type="checkbox"/> 133~266ft <input type="checkbox"/> 266~399ft <input type="checkbox"/> 399ft~533ft <input type="checkbox"/> 533~655ft
	AIS	<input type="checkbox"/> Off <input type="checkbox"/> On

When SHDSL.bis using 2-pairs(4-wires), the E1 or T1 time slot number can only use even number

When E1 framer is PCM31C and PCM30C and set pass through ON, no fractional function can be use.

4.5.2. SHDTU03b-E1/T1 -- T1 Interface mode

NTU	Interface	<input type="checkbox"/> E1 <input type="checkbox"/> T1
	Type	<input type="checkbox"/> STU-R <input type="checkbox"/> STU-C-INTCLK <input type="checkbox"/> STU-C-EXTCLK
SHDSL	Annex	<input type="checkbox"/> A <input type="checkbox"/> B <input type="checkbox"/> F <input type="checkbox"/> G
	PSD	<input type="checkbox"/> SYM <input type="checkbox"/> ASYM
	SNR Margin	(-10~21)
	Pair Mode	<input type="checkbox"/> 1 Pair <input type="checkbox"/> 2 pair (For SHDTU03bA-E1/T1 only)
T1	Channel	<input type="checkbox"/> SF <input type="checkbox"/> ESF <input type="checkbox"/> Unframed
	Slot Number	
	First Slot	
	LBO	<input type="checkbox"/> 0~133ft <input type="checkbox"/> 133~266ft <input type="checkbox"/> 266~399ft <input type="checkbox"/> 399ft~533ft <input type="checkbox"/> 533~655ft
	AIS	<input type="checkbox"/> Off <input type="checkbox"/> On

When SHDSL.bis using 2-pairs(4-wires), the T1 time slot number can only use even number

4.6 SHDTU03b-31T

4.6.1. SHDTU03b-31T -- E1 Interface mode

NTU	Interface	<input type="checkbox"/> E1 <input type="checkbox"/> Serial <input type="checkbox"/> Ethernet <input type="checkbox"/> E1+Serial <input type="checkbox"/> E1+Ethernet <input type="checkbox"/> T1 <input type="checkbox"/> T1+Serial <input type="checkbox"/> T1+Ethernet
	Type	<input type="checkbox"/> STU-R <input type="checkbox"/> STU-C-INTCLK <input type="checkbox"/> STU-C-EXTCLK
SHDSL	Annex	<input type="checkbox"/> A <input type="checkbox"/> B <input type="checkbox"/> F <input type="checkbox"/> G
	PSD	<input type="checkbox"/> SYM <input type="checkbox"/> ASYM
	SNR Margin	(-10~21)
	Pair Mode	<input type="checkbox"/> 1 Pair <input type="checkbox"/> 2 pair (For SHDTU03bA-31T only)
E1	Channel	<input type="checkbox"/> CM31 <input type="checkbox"/> PCM31C <input type="checkbox"/> PCM30 <input type="checkbox"/> PCM30C <input type="checkbox"/> Unframed
	Pass Through	<input type="checkbox"/> Off <input type="checkbox"/> On
	Slot Number	
	First Slot	
	Code	<input type="checkbox"/> HDB3 <input type="checkbox"/> AMI
	AIS	<input type="checkbox"/> Off <input type="checkbox"/> On
	Build Outs	<input type="checkbox"/> 75 Ohm <input type="checkbox"/> 120 Ohm

When SHDSL.bis using 2-pairs(4-wires), the E1 time slot number can only use even number

When E1 framer is PCM31C and PCM30C and set pass through ON, no fractional function can be use.

4.6.2. SHDTU03b-31T -- T1 Interface mode

NTU	Interface	<input type="checkbox"/> E1 <input type="checkbox"/> Serial <input type="checkbox"/> Ethernet <input type="checkbox"/> E1+Serial <input type="checkbox"/> E1+Ethernet <input type="checkbox"/> T1 <input type="checkbox"/> T1+Serial <input type="checkbox"/> T1+Ethernet
	Type	<input type="checkbox"/> STU-R <input type="checkbox"/> STU-C-INTCLK <input type="checkbox"/> STU-C-EXTCLK
SHDSL	Annex	<input type="checkbox"/> A <input type="checkbox"/> B <input type="checkbox"/> F <input type="checkbox"/> G
	PSD	<input type="checkbox"/> SYM <input type="checkbox"/> ASYM
	SNR Margin	(-10~21)
	Pair Mode	<input type="checkbox"/> 1 Pair <input type="checkbox"/> 2 pair (For SHDTU03bA-31T only)
T1	Channel	<input type="checkbox"/> SF <input type="checkbox"/> ESF <input type="checkbox"/> Unframed
	Slot Number	
	First Slot	
	LBO	<input type="checkbox"/> 0~133ft <input type="checkbox"/> 133~266ft <input type="checkbox"/> 266~399ft <input type="checkbox"/> 399ft~533ft <input type="checkbox"/> 533~655ft
	AIS	<input type="checkbox"/> Off <input type="checkbox"/> On

When SHDSL.bis using 2-pairs(4-wires), the T1 time slot number can only use even number

4.6.3. SHDTU03b-31T -- Serial Interface mode

NTU	Interface	<input type="checkbox"/> E1 <input type="checkbox"/> Serial <input type="checkbox"/> Ethernet <input type="checkbox"/> E1+Serial <input type="checkbox"/> E1+Ethernet <input type="checkbox"/> T1 <input type="checkbox"/> T1+Serial <input type="checkbox"/> T1+Ethernet		
	Type	<input type="checkbox"/> STU-R <input type="checkbox"/> STU-C-INTCLK <input type="checkbox"/> STU-C-EXTCLK		
SHDSL	Annex	<input type="checkbox"/> A <input type="checkbox"/> B <input type="checkbox"/> F <input type="checkbox"/> G		
	PSD	<input type="checkbox"/> SYM <input type="checkbox"/> ASYM		
	SNR Margin	(-10~21)		
	Pair Mode	<input type="checkbox"/> 1 Pair <input type="checkbox"/> 2 pair (For SHDTU03bA-31T only)		
Serial	Interface	<input type="checkbox"/> V.35 <input type="checkbox"/> X.21		
	Data Rate	<input type="checkbox"/> Nx64K <input type="checkbox"/> T1 mode		
		1 Pair	Annex A/B	(1~36)
			Annex F/G	(1~89)
		2 Pair	Annex A/B	(2~72)
			Annex F/G	(2~128)
		Clock	<input type="checkbox"/> Normal <input type="checkbox"/> Inverse	
	RTS	<input type="checkbox"/> On <input type="checkbox"/> From DTE		
	CTS	<input type="checkbox"/> On <input type="checkbox"/> Off <input type="checkbox"/> From RTS		
	DSR	<input type="checkbox"/> On <input type="checkbox"/> Off <input type="checkbox"/> From DTR		
DCD	<input type="checkbox"/> On <input type="checkbox"/> Off <input type="checkbox"/> From DSL			
Delay	<input type="checkbox"/> 0mS <input type="checkbox"/> 1mS <input type="checkbox"/> 2mS <input type="checkbox"/> 3mS			

When SHDSL.bis using 2-pairs(4-wires), the Serial Nx64K data rate number can only use even number

4.6.4. SHDTU03b-31T -- Ethernet Interface mode

NTU	Interface	<input type="checkbox"/> E1 <input type="checkbox"/> Serial <input type="checkbox"/> Ethernet <input type="checkbox"/> E1+Serial <input type="checkbox"/> E1+Ethernet <input type="checkbox"/> T1 <input type="checkbox"/> T1+Serial <input type="checkbox"/> T1+Ethernet		
	Type	<input type="checkbox"/> STU-R <input type="checkbox"/> STU-C-INTCLK <input type="checkbox"/> STU-C-EXTCLK		
SHDSL	Annex	<input type="checkbox"/> A <input type="checkbox"/> B <input type="checkbox"/> F <input type="checkbox"/> G		
	PSD	<input type="checkbox"/> SYM <input type="checkbox"/> ASYM		
	SNR Margin	(-10~21)		
	Pair Mode	<input type="checkbox"/> 1 Pair <input type="checkbox"/> 2 pair (For SHDTU03bA-31T only)		
Ethernet	Date Rate	<input type="checkbox"/> Nx64K <input type="checkbox"/> T1 mode		
		1 Pair	Annex A/B	(1~36)
			Annex F/G	(1~89)
		2 Pair	Annex A/B	(2~72)
	Annex F/G		(2~178)	
	Auto Config	<input type="checkbox"/> Disable <input type="checkbox"/> Enable		
	Duplex	<input type="checkbox"/> Full <input type="checkbox"/> Half		
Speed	<input type="checkbox"/> 100M <input type="checkbox"/> 10M			

When SHDSL.bis using 2-pairs(4-wires), the Ethernet Nx64K data rate number can only use even number

4.6.5. SHDTU03b-31T -- E1+ Serial Interface mode

NTU	Interface	<input type="checkbox"/> E1 <input type="checkbox"/> Serial <input type="checkbox"/> Ethernet <input type="checkbox"/> E1+Serial <input type="checkbox"/> E1+Ethernet <input type="checkbox"/> T1 <input type="checkbox"/> T1+Serial <input type="checkbox"/> T1+Ethernet
	Type	<input type="checkbox"/> STU-R <input type="checkbox"/> STU-C-INTCLK <input type="checkbox"/> STU-C-EXTCLK
SHDSL	Annex	<input type="checkbox"/> A <input type="checkbox"/> B <input type="checkbox"/> F <input type="checkbox"/> G
	PSD	<input type="checkbox"/> SYM <input type="checkbox"/> ASYM
	SNR Margin	(-10~21)
	Pair Mode	<input type="checkbox"/> 1 Pair <input type="checkbox"/> 2 pair (For SHDTU03ba-31T only)
E1	Channel	<input type="checkbox"/> PCM31 <input type="checkbox"/> PCM31C <input type="checkbox"/> PCM30 <input type="checkbox"/> PCM30C <input type="checkbox"/> Unframed
	Slot Number	
	First Slot	
	Code	<input type="checkbox"/> HDB3 <input type="checkbox"/> AMI
	AIS	<input type="checkbox"/> Off <input type="checkbox"/> On
	Build Outs	<input type="checkbox"/> 75 Ohm <input type="checkbox"/> 120 Ohm
Serial	Interface	<input type="checkbox"/> V.35 <input type="checkbox"/> X.21
	Data Rate	<input type="checkbox"/> Nx64K <input type="checkbox"/> T1 mode
	Clock	<input type="checkbox"/> Normal <input type="checkbox"/> Inverse
	RTS	<input type="checkbox"/> On <input type="checkbox"/> From DTE
	CTS	<input type="checkbox"/> On <input type="checkbox"/> Off <input type="checkbox"/> From RTS
	DSR	<input type="checkbox"/> On <input type="checkbox"/> Off <input type="checkbox"/> From DTR
	DCD	<input type="checkbox"/> On <input type="checkbox"/> Off <input type="checkbox"/> From DSL
Delay	<input type="checkbox"/> 0mS <input type="checkbox"/> 1mS <input type="checkbox"/> 2mS <input type="checkbox"/> 3mS	

When SHDSL.bis using 2-pairs(4-wires), the E1 time slot number and Serial Nx64K data rate number can only use even number

When E1 framer is PCM31C and PCM30C and set pass through ON, no fractional function can be use.

4.6.6. SHDTU03b-31T -- E1 + Ethernet Interface mode

NTU	Interface	<input type="checkbox"/> E1 <input type="checkbox"/> Serial <input type="checkbox"/> Ethernet <input type="checkbox"/> E1+Serial <input type="checkbox"/> E1+Ethernet <input type="checkbox"/> T1 <input type="checkbox"/> T1+Serial <input type="checkbox"/> T1+Ethernet
	Type	<input type="checkbox"/> STU-R <input type="checkbox"/> STU-C-INTCLK <input type="checkbox"/> STU-C-EXTCLK
SHDSL	Annex	<input type="checkbox"/> A <input type="checkbox"/> B <input type="checkbox"/> F <input type="checkbox"/> G
	PSD	<input type="checkbox"/> SYM <input type="checkbox"/> ASYM
	SNR Margin	(-10~21)
	Pair Mode	<input type="checkbox"/> 1 Pair <input type="checkbox"/> 2 pair (For SHDTU03bA-31T only)
E1	Channel	<input type="checkbox"/> PCM31 <input type="checkbox"/> PCM31C <input type="checkbox"/> PCM30 <input type="checkbox"/> PCM30C <input type="checkbox"/> Unframed
	Slot Number	
	First Slot	
	Code	<input type="checkbox"/> HDB3 <input type="checkbox"/> AMI
	AIS	<input type="checkbox"/> Off <input type="checkbox"/> On
	Build Outs	<input type="checkbox"/> 75 Ohm <input type="checkbox"/> 120 Ohm
Ethernet	Date Rate	<input type="checkbox"/> Nx64K <input type="checkbox"/> T1 mode
	Auto Config	<input type="checkbox"/> Disable <input type="checkbox"/> Enable
	Duplex	<input type="checkbox"/> Full <input type="checkbox"/> Half
	Speed	<input type="checkbox"/> 100M <input type="checkbox"/> 10M

When SHDSL.bis using 2-pairs(4-wires), the E1 time slot number and Ethernet Nx64K data rate can only use even number.
When E1 framer is PCM31C and PCM30C and set pass through ON, no fractional function can be use.

4.6.7. SHDTU03b-31T -- T1+ Serial Interface mode

NTU	Interface	<input type="checkbox"/> E1 <input type="checkbox"/> Serial <input type="checkbox"/> Ethernet <input type="checkbox"/> E1+Serial <input type="checkbox"/> E1+Ethernet <input type="checkbox"/> T1 <input type="checkbox"/> T1+Serial <input type="checkbox"/> T1+Ethernet
	Type	<input type="checkbox"/> STU-R <input type="checkbox"/> STU-C-INTCLK <input type="checkbox"/> STU-C-EXTCLK
SHDSL	Annex	<input type="checkbox"/> A <input type="checkbox"/> B <input type="checkbox"/> F <input type="checkbox"/> G
	PSD	<input type="checkbox"/> SYM <input type="checkbox"/> ASYM
	SNR Margin	(-10~21)
	Pair Mode	<input type="checkbox"/> 1 Pair <input type="checkbox"/> 2 pair (For SHDTU03bA-31T only)
T1	Channel	<input type="checkbox"/> SF <input type="checkbox"/> ESF <input type="checkbox"/> Unframed
	Slot Number	
	First Slot	
	LBO	<input type="checkbox"/> 0~133ft <input type="checkbox"/> 133~266ft <input type="checkbox"/> 266~399ft <input type="checkbox"/> 399ft~533ft <input type="checkbox"/> 533~655ft
	AIS	<input type="checkbox"/> Off <input type="checkbox"/> On
Serial	Interface	<input type="checkbox"/> V.35 <input type="checkbox"/> X.21
	Data Rate	<input type="checkbox"/> Nx64K <input type="checkbox"/> T1 mode
	Clock	<input type="checkbox"/> Normal <input type="checkbox"/> Inverse
	RTS	<input type="checkbox"/> On <input type="checkbox"/> From DTE
	CTS	<input type="checkbox"/> On <input type="checkbox"/> Off <input type="checkbox"/> From RTS
	DSR	<input type="checkbox"/> On <input type="checkbox"/> Off <input type="checkbox"/> From DTR
	DCD	<input type="checkbox"/> On <input type="checkbox"/> Off <input type="checkbox"/> From DSL
Delay	<input type="checkbox"/> 0mS <input type="checkbox"/> 1mS <input type="checkbox"/> 2mS <input type="checkbox"/> 3mS	

When SHDSL.bis using 2-pairs(4-wires), the T1 time slot number and Serial Nx64K data rate can only use even number.

4.6.8. SHDTU03b-31T -- T1 + Ethernet Interface mode

NTU	Interface	<input type="checkbox"/> E1 <input type="checkbox"/> Serial <input type="checkbox"/> Ethernet <input type="checkbox"/> E1+Serial <input type="checkbox"/> E1+Ethernet <input type="checkbox"/> T1 <input type="checkbox"/> T1+Serial <input type="checkbox"/> T1+Ethernet
	Type	<input type="checkbox"/> STU-R <input type="checkbox"/> STU-C-INTCLK <input type="checkbox"/> STU-C-EXTCLK
SHDSL	Annex	<input type="checkbox"/> A <input type="checkbox"/> B <input type="checkbox"/> F <input type="checkbox"/> G
	PSD	<input type="checkbox"/> SYM <input type="checkbox"/> ASYM
	SNR Margin	(-10~21)
	Pair Mode	<input type="checkbox"/> 1 Pair <input type="checkbox"/> 2 pair (For SHDTU03bA-31T only)
T1	Channel	<input type="checkbox"/> SF <input type="checkbox"/> ESF <input type="checkbox"/> Unframed
	Slot Number	
	First Slot	
	LBO	<input type="checkbox"/> 0~133ft <input type="checkbox"/> 133~266ft <input type="checkbox"/> 266~399ft <input type="checkbox"/> 399ft~533ft <input type="checkbox"/> 533~655ft
	AIS	<input type="checkbox"/> Off <input type="checkbox"/> On
Ethernet	Date Rate	<input type="checkbox"/> Nx64K <input type="checkbox"/> T1 mode
	Auto Config	<input type="checkbox"/> Disable <input type="checkbox"/> Enable
	Duplex	<input type="checkbox"/> Full <input type="checkbox"/> Half
	Speed	<input type="checkbox"/> 100M <input type="checkbox"/> 10M

When SHDSL.bis using 2-pairs(4-wires), the T1 time slot number and Ethernet Nx64K data rate number can only use even number.

5. Configuration with Console Port

This chapter will deal with the details of configuration and operation of this product via console port with terminal emulation program. The configuration of the SHDSL.bis NTU is performed via a menu-driven embedded software, using a standard ASCII terminal or a PC running a terminal emulation application connected to the rear panel CONSOLE port.

Windows includes a terminal emulation program called HyperTerminal. Connect the appropriated communication port from the PC to this device. After the physical connection is made, you are ready to configure this product. Make sure you have connected the supplied RS-232C serial cable (DB9F to RJ-45 Plug) to the console port on the rear panel of this product.

Run the terminal emulation program such as Hyper Terminal with the following setting:

Emulation: VT-100 compatible

Band rate: 115200, Data bits: 8, Parity: None, Stop Bits: 1, Flow Control: None

The following example uses HyperTerminal, supplied with Windows up until Vista release. It can be found by the start path Start>All Programs> Accessories> Communication> HyperTerminal. Since HyperTerminal is no longer included with Vista or Windows 7, please use a free terminal emulation program such as TeraTerm or PuTTY.

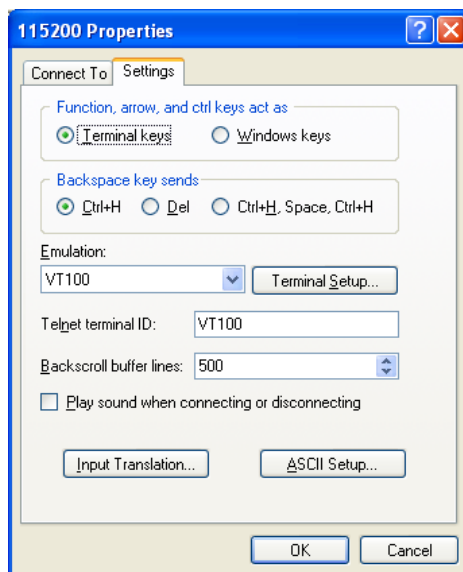
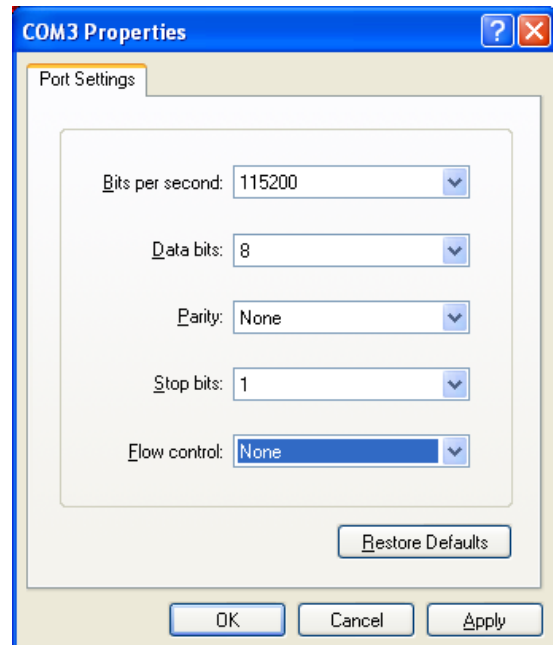
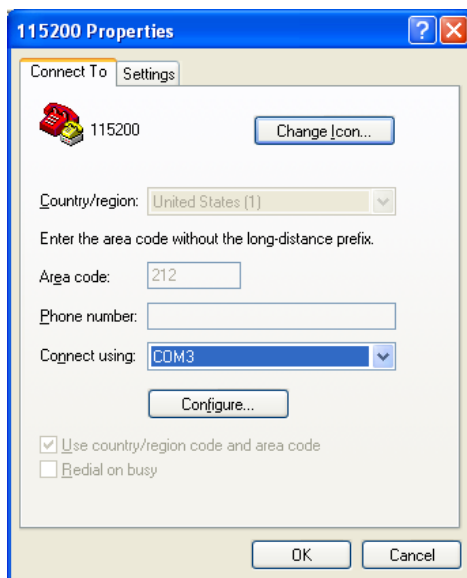

5.1 Login Procedure

At the start up screen, you will see:

```
DownLoad FPGA Code 000120f1/000120f1...0k
SHDSL.bis (E1) Interface, STU_R Mode
Model = 5099B-4W/E1/T1/SER/ETH Software Version = 1.14.08 FPGA Version = 1.30
MCSV 14D9-0000-11416201 / 14D2-0000-114DBEC5

Load SDFE4 FW...
SDFE-4: Firmware download complete!

Press SPACE key to enter console mode configuration!
```

Press the SPACE key until the login screen appears. When you see the login screen, you can logon to device. Username use "admin". When the system prompts you for a password, type "admin" to enter is O.K.

```
User: admin
Password: *****
```

5.2 Window structure

After you type the password, it will display the main menu.

```

-----
                                SHDSL.BIS NTU
-----
>> setup          Configure system
   status         Show running system status
   show           View system configuration
   reboot         Reset and boot system
   upgrade        Console software upgrade
   exit           Quit system

-----

Command:setup <more...>
Message:

-----

<I/K> Move up/down, <J/L> Exit/Enter, <U/O> Move top/bottom

```

Above captured screen shows the common structure for all windows used throughout the configuration console terminal. From top to bottom, the window is divided into four major sections.

The very top line displays the product name as "SHDSL.BIS NTU".

Next a block of commands is listed where the ">>" symbol indicates the current cursor placeholder.

The next block down is the "command" section. The command that is selected and ready for execution is displayed after the "Command:" prompt. The "<"

"Message:" field is used to display

Finally, at the very bottom of the window, the keyboard's cursor keys are listed on the command line.

Move to Top Up Move to bottom



ently available command keys. In some cases, the system. If for some reason your system does not use the keys listed on the help

Menu Commands

Before changing the configuration, the command list will be shown on the window.

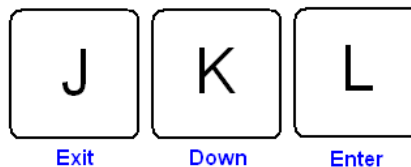

ing table. The operation list will be

Keypads	Description
[UP] or I	Move to above field in the same level menu
[DOWN] or K	Move to below field in the same level menu
U	Move to top field in the same level menu
O	Move to bottom field in the same level menu
[LEFT] or J	Move back to previous menu (Exit)
[RIGHT] , L or [ENTER]	Move forward to submenu(Enter)
[TAB]	To choose another parameters
Ctrl + C	To quit the show data display screen

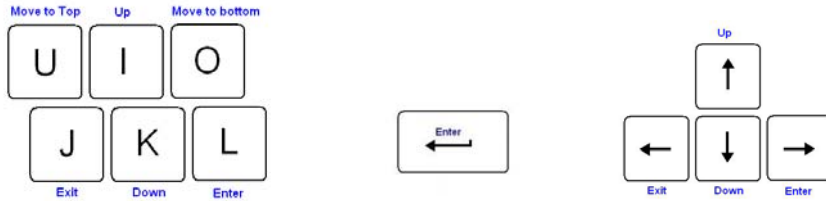

5.3 Main Menu Summary

The main menu is prompted as following:

Menu Title	Function
Setup	Use this menu to setup SHDSL type, SHDSL parameters and E1/V.35/Ethernet parameters or restore factory default setting.
Status	Use this menu to show SHDSL status, E1 /V.35/Ethernet status and statistics or clear the statistics
Show	Use this menu to show general information, all configurations and all configurations in command script.
Reboot	Use this menu to reset and reboot the system
Diag	Use this menu to setup diagnostic utility
Upgrade	Use this menu to upgrade kernel and FPGA.
Exit	Use this menu to exit

When using one of the following cases, there will not be a diagnostic function on the main menu.

- (1) Ethernet interface model.
- (2) Multi-interfaces model, but working as Ethernet interface only.

Menu Tree

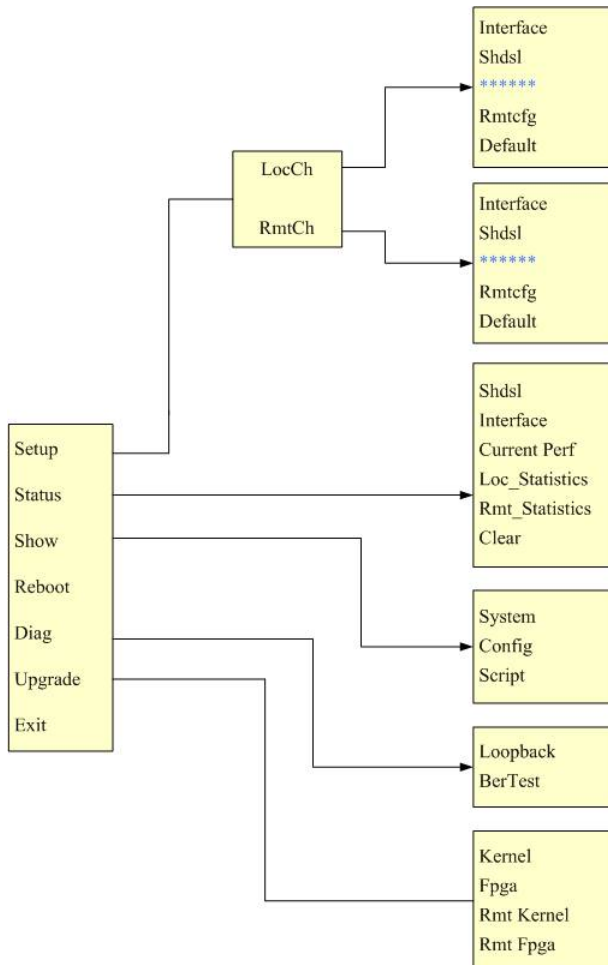

5.4 Configuration

This section provides information about the configuration of SHDSL .Bis NTU. Follow the procedures:

In the main menu, select **setup** and press [ENTER] or [RIGHT]

```
SHDSL .BIS NTU
-----
>> setup          Configure system
   status         Show running system status
   show           View system configuration
   reboot        Reset and boot system
   diag          Diagnostic utility
   upgrade       Console software upgrade
   exit          Quit system

-----

Command:setup <more...> _
Message:

-----

<I/K> Move up/down, <J/L> Exit/Enter, <U/O> Move top/bottom
```

The screen will prompt as following:

```
SHDSL .BIS NTU
-----
>> LocCh          Setup Local Channel
   RmtCh          Setup Remote Channel

-----

Command:LocCh <CR> _
Message:

-----

<I/K> Move up/down, <J/L> Exit/Enter, <U/O> Move top/bottom
```

For setup the local side, select **LocCH** and press [ENTER] or [RIGHT].
Otherwise, setup the remote side by select **RmtCH**.

```

CH A                               SHDSL.BIS NTU
-----
>> Interface      Configure NTU Interface
Shdsl            Configure SHSDL Parameters
E1              Configure E1 Parameters
Rmtcfg          Enable/Disable Remote Config
Default         Restore NTU's Default Setting

-----

Command:Interface <CR>
Message:

-----

<I/K> Move up/down, <J/L> Exit/Enter, <U/O> Move top/bottom

```

5.4.1. [Configure NTU Interface](#)

Setup Interface

```

CH A                               SHDSL.BIS NTU
-----
>> Interface      Configure NTU Interface
Shdsl            Configure SHSDL Parameters
E1              Configure E1 Parameters
Serial          Configure Serial Parameters
Rmtcfg          Enable/Disable Remote Config
Default         Restore NTU's Default Setting

-----

Command:Interface <CR>
Message: Please input the following information.

SHDSL Interface (TAB Select) <E1+Serial>: E1+Serial

-----

<I/K> Move up/down, <J/L> Exit/Enter, <U/O> Move top/bottom

```

If the SHDSL.bis NTU is a multi-interface model, it will display more types of interfaces that can be selected. Use the [TAB] key to choose the different interface types.

Model	Interface modes support
SHDTU03b-E1 E1 interface model	E1
SHDTU03b-E1/T1 E1 + T1 interface model	E1
	T1
SHDTU03b-Data Serial interface model	Serial
SHDTU03b-ET100 Ethernet interface model	Ethernet
SHDTU03b-31 E1+Serial+Ethernet interface model	E1
	Serial
	Ethernet
	E1+Serial
	E1+Ethernet
SHDTU03b-31T E1+T1+ Serial +Ethernet interface model	E1
	T1
	Serial
	Ethernet
	E1+Serial
	E1+Ethernet
	T1 + Serial
	T1 + Ethernet

5.4.2. Configure SHDSL parameters

This section shows how to setup the SHDSL parameters: **SHDSL Mode, Annex type, Psd Mask, SNR margin**.
Select **Shdsl**, and press [ENTER] or [RIGHT].

Setup SHDSL Parameter, Mode

```
CH A                SHDSL . BIS  NTU
-----
>> Mode            Configure SHDSL Mode
Annex              Configure SHDSL Annex
Psd                Configure SHDSL PSD Mask
Margin            Configure SHDSL SNR Margin
Pair Mode         Configure SHDSL Pair Mode

-----
Command:Mode <CR>
Message:

-----
<I/K> Move up/down, <J/L> Exit/Enter, <U/O> Move top/bottom
```

Press [TAB] to select the operating type and press enter to finish setting.

The SHDSL modes have three types: **STU-R, STU-C-INTCLK** and **STU-C-EXTCLK**

INTCLK: The device will generate the appropriate clock speed defined by the speed setting of the interface.

EXTCLK: The device will accept the clock from the interface and will use that clock to receive and transmit data across the interface.

Most point-to-point applications use Internal Clock. If the DTE provides a clock with TX data, the clock can be set to External Clock.

For Ethernet interface model, since Ethernet does not provide a clock, the correct setting for CO side NTU should always be STU-C-INTCLK.

To set the SHDSL Annex type, move the cursor to **Annex** and press [ENTER]. Select the annex type by using [TAB] key.

Set Up SHDSL parameter, Annex

```
CH A                               SHDSL.BIS NTU
-----
Mode                               Configure SHDSL Mode
>> Annex                           Configure SHDSL Annex
Psd                                 Configure SHDSL PSD Mask
Margin                              Configure SHDSL SNR Margin
Pair Mode                           Configure SHDSL Pair Mode

-----

Command:Annex <CR>
Message: Please input the following information.

SHDSL Annex (TAB Select) <Annex-G>: Annex-G

-----

<I/K> Move up/down, <J/L> Exit/Enter, <U/O> Move top/bottom
```

The Annex has four types: A, B, F and G.

To configure the SHDSL PSD, move the cursor to **psd** and press [ENTER]. Select the parameter via [TAB] key.

Set up SHDSL parameter, PSD

```
CH A                               SHDSL.BIS NTU
-----
Mode                               Configure SHDSL Mode
Annex                              Configure SHDSL Annex
>> Psd                             Configure SHDSL PSD Mask
Margin                              Configure SHDSL SNR Margin
Pair Mode                           Configure SHDSL Pair Mode

-----

Command:Psd <CR>
Message: Please input the following information.

SHDSL PSD Mask (TAB Select) <SYM>: SYM

-----

<I/K> Move up/down, <J/L> Exit/Enter, <U/O> Move top/bottom
```

The PSD has two types: **SYM** and **ASYM**.

To set the SHDSL Margin, move the cursor to **margin** and press [ENTER]. Select the margin via [TAB] key and key in the Next margin.

Setup SHDSL parameter, SNR Margin

```

CH A                               SHDSL.BIS  NTU
-----
Mode                               Configure SHDSL Mode
Annex                               Configure SHDSL Annex
Psd                                 Configure SHDSL PSD Mask
>> Margin                           Configure SHDSL SNR Margin
Pair Mode                           Configure SHDSL Pair Mode

-----

Command:Margin <CR>
Message: Please input the following information.

SHDSL Margin <3> (-10~21): 3

-----

<I/K> Move up/down, <J/L> Exit/Enter, <U/O> Move top/bottom

```

SNR margin is an index of line connection. You can see the actual SNR margin in STATUS SHDSL. The larger the SNR margin, the better the line connection. For example, if you set SNR margin in the field as 3, the SHDSL connection will drop down and reconnect when the SNR margin is lower than 3. The setting range is -10 to 21.

Setup SHDSL parameter, Pair Mode

```

CH A                               SHDSL.BIS  NTU
-----
Mode                               Configure SHDSL Mode
Annex                               Configure SHDSL Annex
Psd                                 Configure SHDSL PSD Mask
Margin                             Configure SHDSL SNR Margin
>> Pair Mode                         Configure SHDSL Pair Mode

-----

Command:Pair Mode <CR>
Message: Please input the following information.

SHDSL Wire Mode (TAB Select) <2 Pair>: 2 Pair_

-----

<I/K> Move up/down, <J/L> Exit/Enter, <U/O> Move top/bottom

```

When using 4-wires (2-pair) model, it will show Pair Mode item here. User can select 1 Pair or 2 Pair for the DSL connection.

5.4.3. Configure E1 parameters

When using E1 interface, select the **E1** item and press [ENTER] or [RIGHT].

```
CH A                               SHDSL.BIS NTU
-----
Interface       Configure NTU Interface
Shdsl          Configure SHSDL Parameters
>> E1          Configure E1 Parameters
Serial         Configure Serial Parameters
Rmtcfg        Enable/Disable Remote Config
Default       Restore NTU's Default Setting

-----

Command:E1 <more...>
Message:

-----

<I/K> Move up/down, <J/L> Exit/Enter, <U/O> Move top/bottom
```

The E1 setting includes the Channel (frame mode), line code, AIS and build out settings.

Setup E1 Parameter, Channel

```
CH A                               SHDSL.BIS NTU
-----
>> Channel     Configure E1 Channel
Code          Configure E1 code
Ais          Configure E1 AIS
Build_outs   Configure E1 build outs

-----

Command:Channel <CR>
Message: Please input the following information.

Change E1 Channel (TAB Select) <PCM31>: PCM31

-----

<I/K> Move up/down, <J/L> Exit/Enter, <U/O> Move top/bottom
```

Framing

Framing is required to recover the channelized E1. In transparent operation, the framing is configured as Unframed. In this case the G.SHDSL framer must be set to Nx64 with N=32. For any framing such as FAS or CAS, the G.SHDSL framer must be set to E1, then the E1 framing here may be set accordingly.

Channel	Framing
PCM31	FAS
PCM31C	FAS+CRC4
PCM30	FAS+CAS
PCM30C	FAS+CAS+CRC4
FULL	Unframed

FAS Frame Alignment Signal uses a 7-bits pattern to establish and maintain the frame synchronization. The FAS word is located in timeslot 0 of frame. In FAS mode there are 1~31 timeslot available for use data.

CAS Also known as time slot 16 multi-framing. It requires a multi-framing alignment signal to be present for frame sync. The Multi-frame Alignment Signal (MFAS) is inserted into the 16th timeslot of frame 0 of the 16-frame multi-frame. In CAS mode, there are 30 channels available for user data. If timeslot 16 is included in the unit's mapping, it will be disregarded.

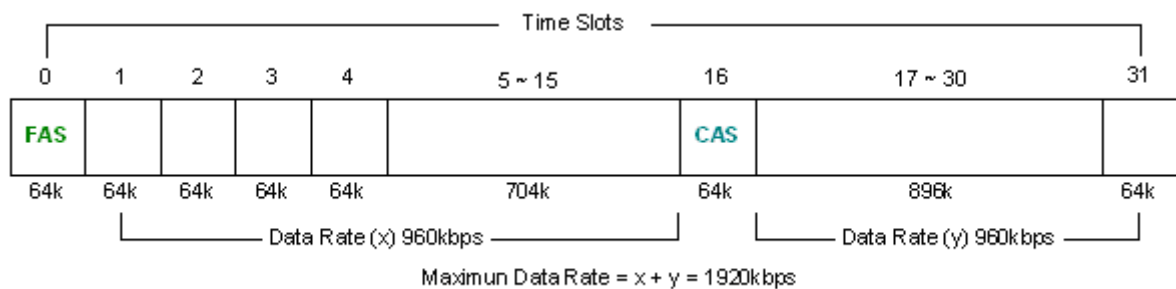

CRC4 The CRC-4 checksum bits are transmitted in the outgoing E1 data stream. Also the received signal is checked for errors. CRC-4 checksum cannot be sent in unframed mode.

Unframed In this mode, user data is inserted into all 32 channels (64k x 32 = 2048k) of the E1 stream. The object of running without framing is to utilize the full bandwidth of the E1 line.

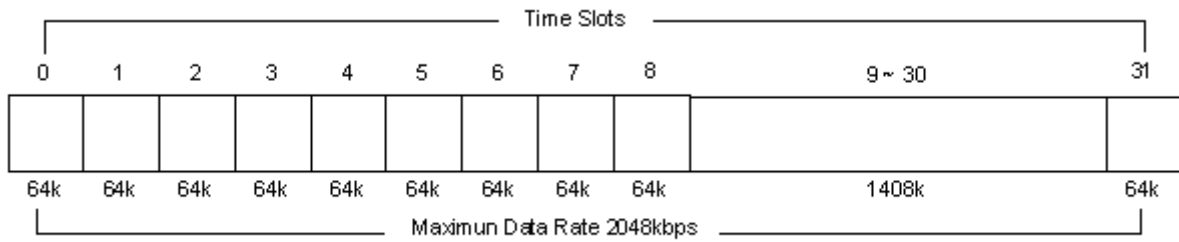

ITU 991.2 (2004) (G.SHDSL .Bis) supports data rate up to 5696Kbps, but G.703 (E1 standard) only supports data rate of 2048kbps so the maximum data rate of SHDSL line, connected with E1 DCEs, depends on data rate of E1, 2048kbps.

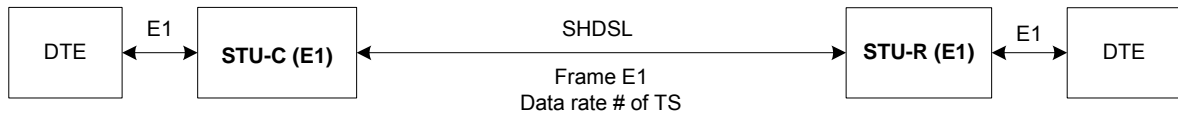

If the connection is E1 vs V.35 or V.35 vs E1, the framer has to use $N \times 64k$. In this case, the data rate depends on value of N . Same as above case, SHDSL and V35 can support up to 5696kbps ($89 \times 64k$) data rate, but E1 supports maximum data rate of 2048kbps ($32 \times 64k$).

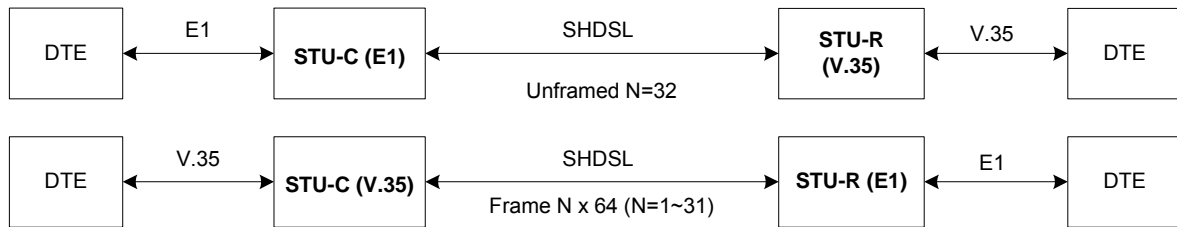

Time slots, N value, are placed in the frame. If time Slot Number is 1 from 1~31 ($N=1\sim31$), it is Fractional E1. For unframed E1, the time Slot Number would be set at 32 ($N=32$).

Fractional E1, PCM31 and PCM31C

For fractional E1 (FE1), the data rate can be from $64k(N=1)$ to $1984k(N=31)$, according to the E1 framing. If the E1 frame is PCM31(FAS) or PCM31C(FAS+CRC4), there are 1~31 available time slot for use. For example, if the data rate of SHDSL line set to be 512k, the time slot number is 8 and first time slot number is 1. The frame is shown as below.

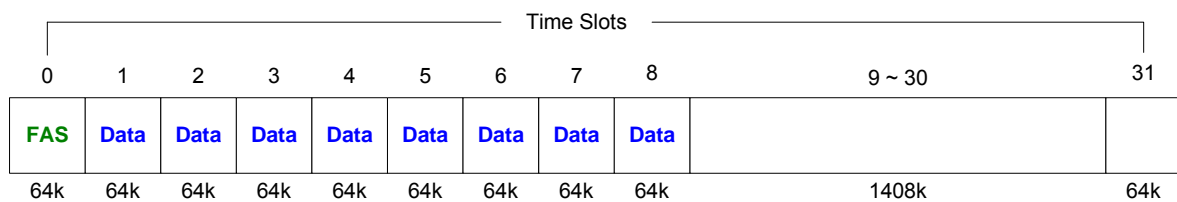

The First Time Slot setting of PCM31(FAS) and PCM31C(FAS+ CRC4) have to follow the rule:

$$\text{First Time Slot} = 31 - \text{Time Slot Number}$$

Fractional E1, PCM30 and PCM30C

Using the E1 framing of PCM30(FAS+CAS) or PCM30C(FAS+CAS+CRC4), the FAS will occupy Time Slot 0 and CAS Time Slot 16. There are only 30 Time Slot left for data. On the other hand, the maximum data rate is 1920kbps.

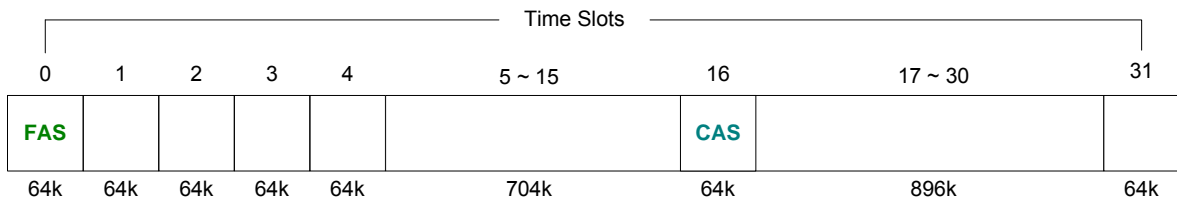

The First Time Slot setting of PCM30(FAS+CAS) and PCM30C(FAS+CAS+CRC4) have to follow the rule:

First Time Slot 30 - Time Slot Number

TS16 cannot be used for data.

Unframed E1

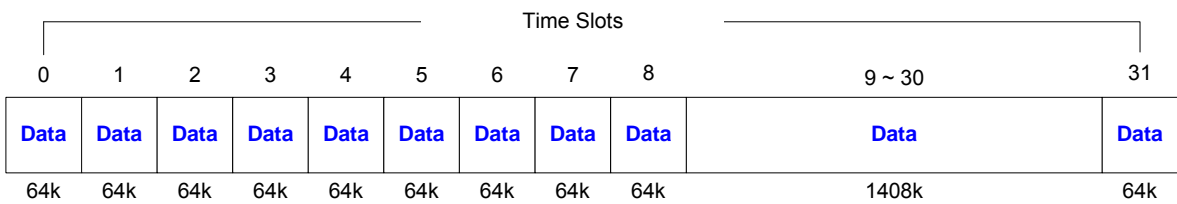

In Unframed E1, there is no framing or channelization. User data are inserted into all 32 channels (64k x 32 = 2048k) of the E1 stream. The object of running without framing is to utilize the full bandwidth of the E1 line. Also, when run in unframed mode, the G.SHDSL.bis modems are completely transparent to any framing when deployed in E1 extension applications.

Setup E1 Parameter, Pass Through

```

CH A                               SHDSL.BIS  NTU
-----
>> Channel          Configure E1 Channel
   Code             Configure E1 code
   Ais              Configure E1 AIS
   Build_outs       Configure E1 build outs

-----

Command:Channel <CR>
Message: Please input the following information.
Change E1 Channel (TAB Select) <PCM30>: PCM30
Change E1 Pass Through (TAB Select) <Off>: Off_

-----

<I/K> Move up/down, <J/L> Exit/Enter, <U/O> Move top/bottom
    
```

When SHDSL.bis using 2-pairs(4-wires), the time slot number can only use even number

When setting the E1 channel on PCM31C, PCM31, PCM30C and PCM30, there is also an E1 Pass Through selection item.

Table of Pass through function with user data rate vs. DSL line rate (for 2-wires)

Channel	Time Slot number	1 st Time Slot	User data rate	Pass Through :	Pass Through :
				On	Off
				DSL line rate	DSL line rate
PCM31/PCM31C	31	1	31	32	31
PCM30/PCM30C	30	1	30	32	30
PCM31/PCM31C	30	1	30	32	30
PCM30/PCM30C	29	1	29	32	29
PCM31/PCM31C	29	1	29	30	29
PCM30/PCM30C	28	1	28	30	28
PCM31/PCM31C	28	1	28	29	28
PCM30/PCM30C	27	1	27	29	27
PCM31/PCM31C	27	1	27	28	27
PCM30/PCM30C	26	1	26	28	26
PCM31/PCM31C	26	1	26	27	26
PCM30/PCM30C	25	1	25	27	25
PCM31/PCM31C	25	1	25	26	25
PCM30/PCM30C	24	1	24	26	24
<input type="checkbox"/>	<input type="checkbox"/>	<input type="checkbox"/>	<input type="checkbox"/>	<input type="checkbox"/>	<input type="checkbox"/>
<input type="checkbox"/>	<input type="checkbox"/>	<input type="checkbox"/>	<input type="checkbox"/>	<input type="checkbox"/>	<input type="checkbox"/>
PCM31/PCM31C	15	10	15	16	15
PCM30/PCM30C	14	10	14	16	14
PCM31/PCM31C	14	5	14	15	14
PCM30/PCM30C	13	5	13	15	13
<input type="checkbox"/>	<input type="checkbox"/>	<input type="checkbox"/>	<input type="checkbox"/>	<input type="checkbox"/>	<input type="checkbox"/>
PCM31/PCM31C	10	5	10	11	10
PCM30/PCM30C	9	5	9	11	9
<input type="checkbox"/>	<input type="checkbox"/>	<input type="checkbox"/>	<input type="checkbox"/>	<input type="checkbox"/>	<input type="checkbox"/>
PCM31/PCM31C	4	1	4	5	4
PCM30/PCM30C	3	1	3	5	3
PCM31/PCM31C	3	1	3	4	3
PCM30/PCM30C	2	1	2	4	3
PCM31/PCM31C	2	1	2	3	3
PCM30/PCM30C	1	1	1	3	3
PCM31/PCM31C	1	1	1	3	3

For example, when channel framing is PCM30 or PCM30C (with time slot number is 30 and first time slot is 1) refer to the following graphic. When Pass Through is set Off, the DSL transfer data will not include the time slots of FAS and CAS. The information of FAS and CAS on remote is re-created.

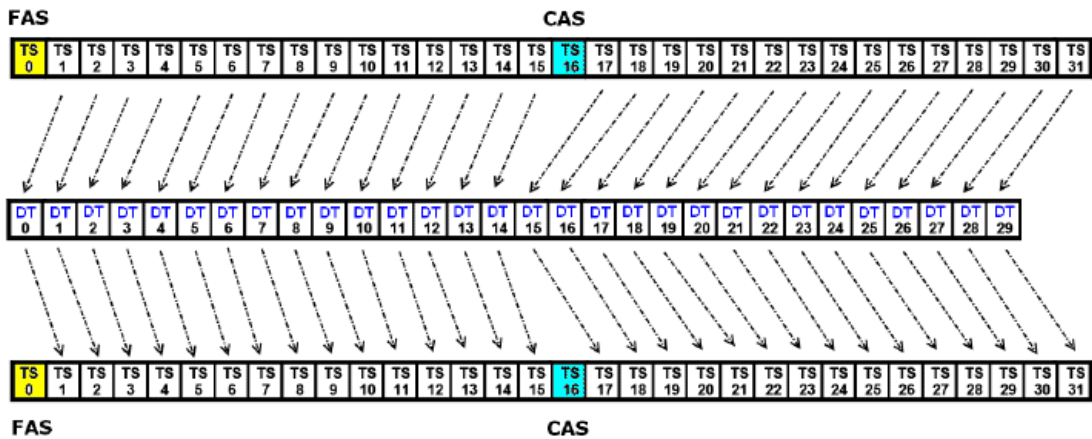

Warning: When the E1 is carrying signaling information for voice, do NOT set pass through Off. Pass through must be set to ON or signaling and other information will be lost.

Setup E1 Parameter, Line Code

```

CH A                               SHDSL.BIS NTU
-----
Channel                            Configure E1 Channel
>> Code                            Configure E1 code
Ais                                 Configure E1 AIS
Build_outs                          Configure E1 build outs

-----

Command:Code <CR>
Message: Please input the following information.

Change E1 Line Code (TAB Select) <HDB3>: HDB3_

-----

<I/K> Move up/down, <J/L> Exit/Enter, <U/O> Move top/bottom

```

The G.SHDSL .Bis NTU supports two different line codings. HDB3 is the most popular and preferred line coding and is also the default setting. AMI line coding is also selectable.

HDB3	In this line coding, the transmitter substitutes a deliberate bipolar violation when excessive zeros in the data stream are detected. The receiver recognizes these special violations and decodes them as zeros. This method enables the network to minimize pulse density requirements. Unless AMI is required for your application, HDB3 should be used whenever possible.
AMI	Alternate Mark Inversion defines a pulse as a "mark," a binary one, as opposed to a zero. In an E1 network connection, signals are transmitted as a sequence of one and zero. One is sent as pulse, and zero is sent as spaces, i.e. no pulse. Every other pulse is inverted from the previous pulse in polarity, so that the signal can be effectively transmitted. This means, however, that a long sequence of zeros in data stream will cause problems, since the NTU receiving the signal relies on the signal to recover the 2048kbps clock.

Setup E1 Parameter, AIS

```

CH A                               SHDSL.BIS NTU
-----
Channel          Configure E1 Channel
Code             Configure E1 code
>> Ais           Configure E1 AIS
Build_outs       Configure E1 build outs

-----

Command:Ais <CR>
Message: Please input the following information.

Change E1 Ais (TAB Select) <Off>: Off

-----

<I/K> Move up/down, <J/L> Exit/Enter, <U/O> Move top/bottom

```

AIS (Alarm Indication Signal) is a method to inform the remote connection that there is a signal or sync problem with the E1. AIS is only valid in framed mode E1, not in Unframed E1. The setting here of AIS enabled (on) or not (off) and is for testing with AIS. When enabled, the E1 will transmit the AIS and it should be confirmed at the remote device (AIS indication lit). After testing, please turn AIS back off.

- Example 1: When STU-R E1 RX line is dropped, STU-R sends the status to STU-C via EOC or command, and then STU-C will send AIS (Alarm Indication Signal) to DTE while AIS function is enabled.

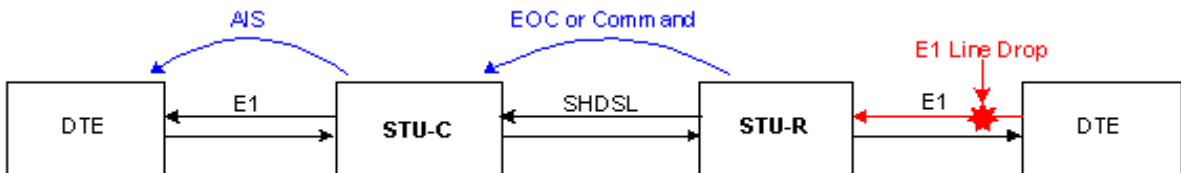

- Example 2: When SHDSL connection drops, STU-R and STU-C both send AIS (Alarm Indication Signal) to DTE in the same time while AIS function is enabled.



Setup E1 Parameter, Build Out

```
CH A                               SHDSL.BIS NTU
-----
Channel        Configure E1 Channel
Code           Configure E1 code
Ais            Configure E1 AIS
>> Build_outs Configure E1 build outs

-----

Command:Build_outs <CR>
Message: Please input the following information.

Change E1 Build Outs (TAB Select) <120 Ohm>: 120 Ohm_

-----

<I/K> Move up/down, <J/L> Exit/Enter, <U/O> Move top/bottom
```

The SHDSL.Bis NTU can support both unbalanced E1 at 75 ohms (BNC) and balanced E1 at 120 ohms (RJ-48C). The settings for impedance are made here under the build out menu setting.

5.4.4. Configure Serial parameters

When using the Serial interface, select the Serial item and press [ENTER] or [RIGHT].

The serial settings include the data rate, clocking and handshaking lines setup.

Setup Serial Parameter, Interface

```
CH A                SHDSL.BIS NTU
-----
>> Interface        Configure Serial Interface
Data rate           Configure Serial Data Rate (N*64)
Clock               Configure Serial clock
Rts                 Configure Serial rts
Cts                 Configure Serial cts
Dsr                 Configure Serial dsr
Dcd                 Configure Serial dcd
Delay               Configure Serial delay

-----
Command:Interface <CR>
Message: Please input the following information.

Change V.35 Interface (TAB Select) <V35>: V35_

-----
<I/K> Move up/down, <J/L> Exit/Enter, <U/O> Move top/bottom
```

There are two interfaces types : V.35 and X.21. (For RS530/449 please select the X.21 interface.)

Setup Serial Parameter, Data Rate - Rate type

```
CH A                SHDSL.BIS NTU
-----
>> Interface        Configure Serial Interface
Data rate           Configure Serial Data Rate (N*64)
Clock               Configure Serial clock
Data               Configure Serial data
Rts                 Configure Serial rts
Cts                 Configure Serial cts
Dsr                 Configure Serial dsr
Dcd                 Configure Serial dcd
Delay               Configure Serial delay

-----
Command:Data rate <CR>
Message: Please input the following information.

rate Type (TAB Select) <N64>: N64_

-----
<I/K> Move up/down, <J/L> Exit/Enter, <U/O> Move top/bottom
```

There are two rate type modes: Nx64K model and T1 mode. When other remote side has T1 interface and unframed mode connect to this side as Serial interface, we must set Serial rate mode as T1 mode.

Setup Serial Parameter, Data Rate

```
CH A                               SHDSL.BIS NTU
-----
Interface      Configure Serial Interface
>> Data rate   Configure Serial Data Rate (N*64)
Clock          Configure Serial clock
Rts            Configure Serial rts
Cts            Configure Serial cts
Dsr            Configure Serial dsr
Dcd            Configure Serial dcd
Delay          Configure Serial delay

-----

Command:Data rate <CR>
Message: Please input the following information.

Change Serial N*64 (TAB Select) <32>: 32

-----

<I/K> Move up/down, <J/L> Exit/Enter, <U/O> Move top/bottom
```

For 2-wires with Annex A and B, the rate can be adjusted in increments of 64kbps from 64kbps to 2304kbps (N=1~36).

For 2-wires with Annex F and G, the rate can be adjusted in increments of 64kbps from 192kbps to 5696kbps (N=3~89).

For 4-wires with Annex A and B, the rate can be adjusted in increments of 64kbps from 128kbps to 4608kbps (N=2~72, even number only).

For 4-wires with Annex F and G, the rate can be adjusted in increments of 64kbps from 384kbps to 8192kbps (N=6~128, even number only).

Setup Serial Parameter, Clock Polarity

```
CH A                               SHDSL.BIS NTU
-----
Interface      Configure Serial Interface
Data rate     Configure Serial Data Rate (N*64)
>> Clock      Configure Serial clock
Rts           Configure Serial rts
Cts           Configure Serial cts
Dsr           Configure Serial dsr
Dcd           Configure Serial dcd
Delay         Configure Serial delay

-----

Command:Clock <CR>
Message: Please input the following information.

Change Serial Clock (TAB Select) <normal>: normal

-----

<I/K> Move up/down, <J/L> Exit/Enter, <U/O> Move top/bottom
```

The data port clock polarity may be adjusted to solve some rare clocking issues. The default setting is 'Normal' clock polarity, where data is sent on the negative transition of the clock, while the option exists to set inverse clock polarity where data is sent on the positive clock transition.

Setup Serial Parameter, RTS

```
CH A                               SHDSL.BIS NTU
-----
Interface      Configure Serial Interface
Data rate      Configure Serial Data Rate (N*64)
Clock          Configure Serial clock
>> Rts         Configure Serial rts
Cts            Configure Serial cts
Dsr            Configure Serial dsr
Dcd            Configure Serial dcd
Delay          Configure Serial delay

-----

Command:Rts <CR>
Message: Please input the following information.

Change Serial RTS (TAB Select) <on>: on

-----

<I/K> Move up/down, <J/L> Exit/Enter, <U/O> Move top/bottom
```

The behavior of the RTS (Request To Send) signal may be set in one of two ways. When set 'on', the RTS signal is always forced on (active low), when set 'from DTE' the RTS signal will follow the DTE's condition. The default setting for RTS is on.

Setup Serial Parameter, CTS

```
CH A                               SHDSL.BIS NTU
-----
Interface      Configure Serial Interface
Data rate      Configure Serial Data Rate (N*64)
Clock          Configure Serial clock
Rts            Configure Serial rts
>> Cts         Configure Serial cts
Dsr            Configure Serial dsr
Dcd            Configure Serial dcd
Delay          Configure Serial delay

-----

Command:Cts <CR>
Message: Please input the following information.

Change Serial CTS (TAB Select) <from_rts>: from_rts_

-----

<I/K> Move up/down, <J/L> Exit/Enter, <U/O> Move top/bottom
```

The behavior of the CTS (Clear To Send) signal may be set in one of three ways. When set 'on', the CTS signal is always forced on (active low), when set 'off' the signal is always forced off, or CTS will follow RTS (Request To Send) condition of 'on' for RTS on 'off' for RTS off. The default setting for CTS is to follow RTS.

Setup Serial Parameter, DSR

```
CH A                                SHDSL.BIS NTU
-----
Interface      Configure Serial Interface
Data rate      Configure Serial Data Rate (N*64)
Clock          Configure Serial clock
Rts            Configure Serial rts
Cts            Configure Serial cts
>> Dsr         Configure Serial dsr
Dcd            Configure Serial dcd
Delay          Configure Serial delay

-----
Command:Dsr <CR>
Message: Please input the following information.

Change Serial DSR (TAB Select) <on>: on

-----
<I/K> Move up/down, <J/L> Exit/Enter, <U/O> Move top/bottom
```

The behavior of the DSR (Data Set Ready) signal may be set in one of three ways. When set 'on', the DSR signal is always forced on (active low), when set 'off' the signal is always forced off or DSR will follow DTR (Data Terminal Ready) condition of 'on' for DTR on or 'off' for DTR off. The default setting for DSR is on.

Setup Serial Parameter, DCD

```
CH A                                SHDSL.BIS NTU
-----
Interface      Configure Serial Interface
Data rate      Configure Serial Data Rate (N*64)
Clock          Configure Serial clock
Rts            Configure Serial rts
Cts            Configure Serial cts
Dsr            Configure Serial dsr
>> Dcd         Configure Serial dcd
Delay          Configure Serial delay

-----
Command:Dcd <CR>
Message: Please input the following information.

Change Serial DCD (TAB Select) <from_dsl>: from_dsl_

-----
<I/K> Move up/down, <J/L> Exit/Enter, <U/O> Move top/bottom
```

The behavior of the DCD (Data Carrier Detect) signal may be set in one of three ways. When set 'on', the DCD signal is always forced on (active low), when set 'off' the signal is always forced off, or DCD will follow the DSL condition of 'on' for DSL link or 'off' for no link. The default setting for DCD is to follow the DSL link status.

Setup Serial Parameter, Delay

```
CH A                               SHDSL.BIS NTU
-----
Interface      Configure Serial Interface
Data rate      Configure Serial Data Rate (N*64)
Clock          Configure Serial clock
Rts            Configure Serial rts
Cts            Configure Serial cts
Dsr            Configure Serial dsr
Dcd            Configure Serial dcd
>> Delay      Configure Serial delay

-----

Command:Delay <CR>
Message: Please input the following information.

Change Serial Delay <3> (0~3):

-----

<I/K> Move up/down, <J/L> Exit/Enter, <U/O> Move top/bottom
```

The delay setting is used to cause a delay for CTS to follow RTS. The delay setting may be set 0, 1, 2 or 3 milliseconds. The default setting is 3 milliseconds.

It works only for the setting: *CTS follow RTS* and *RTS follow from DTE*.

5.4.5. Configure Ethernet parameter

When using the Ethernet interface mode, select the Ethernet item and press [ENTER] or [RIGHT].

```
CH A                               SHDSL.BIS NTU
-----
Interface      Configure NTU Interface
Shdsl          Configure SHSDL Parameters
>> Ethernet    Configure Ethernet Parameters
Rmtcfg         Enable/Disable Remote Config
Default        Restore NTU's Default Setting

-----

Command:Ethernet <more...>
Message:

-----

<I/K> Move up/down, <J/L> Exit/Enter, <U/O> Move top/bottom
```

The Ethernet settings include the data rate plus the port setting between auto-negotiation (default) or forced mode for duplex and speed.

Setup Ethernet Parameter, Data Rate – Rate type

```
CH A                               SHDSL.BIS NTU
-----
>> Rate                            Configure Ethernet Data Rate(N*64K)
  Auto                              Configure Ethernet Auto Config
  Duplex                            Configure Ethernet Duplex
  Speed                             Configure Ethernet Speed

-----

Command:Rate <CR>
Message: Please input the following information.

Rate Mode (TAB Select) <N64>: N64_

-----

<I/K> Move up/down, <J/L> Exit/Enter, <U/O> Move top/bottom
```

There are two modes: Nx64K model and T1 mode. When the remote side has T1 interface and unframed mode connect to this side as Ethernet interface, we must set Ethernet rate mode as T1 mode.

Setup Ethernet Parameter, Data Rate

```
CH A                               SHDSL.BIS NTU
-----
>> Rate                            Configure Ethernet Data Rate(N*64K)
  Auto                              Configure Ethernet Auto Config
  Duplex                            Configure Ethernet Duplex
  Speed                             Configure Ethernet Speed

-----

Command:Rate <CR>
Message: Please input the following information.

Change Ethernet Rate (TAB Select) <36>: 36

-----

<I/K> Move up/down, <J/L> Exit/Enter, <U/O> Move top/bottom
```

For 2-wires with Annex A and B, the rate can be adjusted in increments of 64kbps from 64kbps to 2304kbps (N=1~36).
For 2-wires with Annex F and G, the rate can be adjusted in increments of 64kbps from 192kbps to 5696kbps (N=3~89).
For 4-wires with Annex A and B, the rate can be adjusted in increments of 64kbps from 128kbps to 4608kbps (N=2~72, even number only).
For 4-wires with Annex F and G, the rate can be adjusted in increments of 64kbps from 384kbps to 11392kbps (N=6~178, even number only).

Setup Interface Parameter, Negotiation

```
CH A                               SHDSL.BIS NTU
-----
Rate                               Configure Ethernet Data Rate(N*64K)
>> Auto                            Configure Ethernet Auto Config
Duplex                              Configure Ethernet Duplex
Speed                               Configure Ethernet Speed

-----

Command:Auto <CR>
Message: Please input the following information.

Change Ethernet Auto Config (TAB Select) <Enable>: Enable

-----

<I/K> Move up/down, <J/L> Exit/Enter, <U/O> Move top/bottom
```

The Ethernet settings include the choice between auto-negotiation (default) or forced mode for duplex and speed. Be very careful to set both Ethernet devices on a link to both auto or forced and do not mix or a duplex mismatch could result.

Setup Ethernet Parameter, Duplex

```
CH A                               SHDSL.BIS NTU
-----
Rate                               Configure Ethernet Data Rate(N*64K)
Auto                               Configure Ethernet Auto Config
>> Duplex                           Configure Ethernet Duplex
Speed                               Configure Ethernet Speed

-----

Command:Duplex <CR>
Message: Please input the following information.

Change Ethernet Duplex (TAB Select) <Full-Duplex>: Full-Duplex

-----

<I/K> Move up/down, <J/L> Exit/Enter, <U/O> Move top/bottom
```

When auto negotiation setup is **disable**, there has to be a selection of duplex mode: **Full-Duplex** and **Half-Duplex**. Be very careful to set both Ethernet devices on a link to the same duplex setting or a duplex mismatch could result.

Setup Ethernet Parameter, Speed

```
CH A                               SHDSL.BIS NTU
-----
Rate                               Configure Ethernet Data Rate(N*64K)
Auto                               Configure Ethernet Auto Config
Duplex                             Configure Ethernet Duplex
>> Speed                           Configure Ethernet Speed

-----

Command:Speed <CR>
Message: Please input the following information.

Change Ethernet Speed (TAB Select) <100M>: 100M_

-----

<I/K> Move up/down, <J/L> Exit/Enter, <U/O> Move top/bottom
```

When auto negotiation is **Disable**, the forced mode settings for speed can be set between: **10M** and **100M**. If auto negotiation is **Enable**, the items **Duplex** and **Speed** cannot be set. The message will display "Ethernet is in auto negotiate".

5.4.6. Configure T1 parameter

When using the T1 interface mode, select the T1 item and press [ENTER] or [RIGHT].

```
CH A                               SHDSL.BIS NTU
-----
Interface                           Configure NTU Interface
Shdsl                               Configure SHDSL Parameters
>> T1                               Configure T1 Parameters
Rmtcfg                              Enable/Disable Remote Config
Default                             Restore NTU's Default Setting

-----

Command:T1 <more...>
Message:

-----

<I/K> Move up/down, <J/L> Exit/Enter, <U/O> Move top/bottom
```

The T1 settings include the Channel, Number of time slots , First time slots, LBO and AIS.

Setup T1 Parameter, Channel

```
CH A                               SHDSL.BIS NTU
-----
>> Channel          Configure T1 Channel
LBO                 Configure T1 LBO
AIS                 Configure T1 AIS

-----

Command:Channel <CR>
Message: Please input the following information.

Change T1 Channel (TAB Select) <SF>: SF

-----

<I/K> Move up/down, <J/L> Exit/Enter, <U/O> Move top/bottom
```

The Superframe(SF) (also called D4 or **193S**) framing format defines a superframe as 12 frames.

The Extended Superframe (ESF) (also called **193E**) frame format groups 24 frames into its superframe.

Both the SF and ESF framing formats provide an actual payload data rate of 1.536 Mbps ($192/193 = 1.536/1.544$).

The T1 interface can be programmed to encode/decode its transmit/receive signals using Bipolar with Eight Zero Suppression (**B8ZS**) coding.

Each T1 frame contains 1 byte of voice data for each of the 24 channels, that system needs then 8000 frames per second to maintain those 24 simultaneous voice channels. Because each frame of a T1 is 193 bits in length (24 channels X 8 bits per channel + 1 framing bit = 193 bits), 8000 frames per second is multiplied by 193 bits to yield a transfer rate of 1.544 Mbit/s ($8000 \times 193 = 1544000$).

The T1 format provides a 64 Kbps channel for each of 24 individual channels. Each of these channels is called a DS-0 channel or a time slot and consists of an eight-bit sample. A T1 frame is constructed by time division multiplexing these 24 time slots and inserting a framing bit at the beginning of the series. This results in 192 bits of channel data, plus a framing bit (F-bit), for a total of 193 bits in a frame. Multiple frames are then grouped into superframes of 12 or 24 frames to provide for framing synchronization and signaling.

Setup T1 Parameter, Time Slot number and First time slot

```
CH A                                SHDSL.BIS NTU
-----
>> Channel          Configure T1 Channel
LBO                 Configure T1 LBO
Ais                 Configure T1 AIS

-----

Command:Channel <CR>
Message: Please input the following information.

Change T1 Channel (TAB Select) <SF>: SF
Set Number of Time Slots (TAB Select) <12>: 12
Change N64Framer 1st Slot <1> (1~12): 1

-----

<I/K> Move up/down, <J/L> Exit/Enter, <U/O> Move top/bottom
```

For fractional T1, the data rate is from 64k(N=1) to 1536k(N=24), according to the T1 framing.
When SHDSL.bis is using 2-pairs(4-wires), the time slot number can only use even number

Setup T1 Parameter, Channel use Unframed mode

```
CH A                                SHDSL.BIS NTU
-----
>> Channel          Configure T1 Channel
LBO                 Configure T1 LBO
Ais                 Configure T1 AIS

-----

Command:Channel <CR>
Message: Please input the following information.

Change T1 Channel (TAB Select) <UNFRAMED>: UNFRAMED_

-----

<I/K> Move up/down, <J/L> Exit/Enter, <U/O> Move top/bottom
```

Unframed: All transmitted bits are used as data bits. This selection must be used when the clock rate of the remote unit is set at 1.544 Mbps. In this mode the T1 signal is passed transparently without regard to framing.

The table of number of time slot vs. 1st time slot:

Channel	Number of slot	1 st slot
SF	24	1
ESF	23	1~2
	22	1~3
	21	1~4
	20	1~5
	19	1~6
	18	1~7
	17	1~8
	16	1~9
	15	1~10
	14	1~11
	13	1~12
	12	1~13
	11	1~14
	10	1~15
	9	1~16
	8	1~17
	7	1~18
	6	1~19
	5	1~20
	4	1~21
	3	1~22
	2	1~23
	1	1~24

Setup T1 Parameter, LBO

```

CH A                               SHDSL.BIS  NTU
-----
>> Channel          Configure T1 Channel
   LBO              Configure T1 LBO
   Ais              Configure T1 AIS

-----
Command:LBO <CR>
Message: Please input the following information.

Change T1 LBO (TAB Select) <0 to 133ft>: 0 to 133ft_

-----
<I/K> Move up/down, <J/L> Exit/Enter, <U/O> Move top/bottom

```

LBO (Line build-out) setting is an inherent part of T1 network element transmission circuitry. Because cable lengths between T1 device and NTU vary, LBO settings are designed to adjust the output power of the transmission signal to achieve equal level point (ELP) at the NTU.

For short distance of T1 cable, this device must decrease outgoing signal strength.

There are five type T1 LBO for selection : 0 ~133ft , 133 ~ 266ft , 266 ~399 ft , 399 ft ~ 533ft , 533ft ~ 655ft

Setup T1 Parameter, AIS

```
CH A                               SHDSL.BIS NTU
-----
Channel                            Configure T1 Channel
LBO                                Configure T1 LBO
>> Ais                             Configure T1 AIS

-----

Command:Ais <CR>
Message: Please input the following information.

Change T1 Ais (TAB Select) <Off>: Off_

-----

<I/K> Move up/down, <J/L> Exit/Enter, <U/O> Move top/bottom
```

AIS (Alarm Indication Signal) is a method to inform the remote connection that there is a signal or sync problem with the T1.

5.4.7. Remote configuration

You can set the "Enable/Disable function" to let the remote side configure parameters to this device remotely.

```
CH A                               SHDSL.BIS NTU
-----
Interface                          Configure NTU Interface
Shdsl                              Configure SHDSL Parameters
Ethernet                          Configure Ethernet Parameters
>> Rmtcfg                          Enable/Disable Remote Config
Default                            Restore NTU's Default Setting

-----

Command:Rmtcfg <CR>
Message: Please input the following information.

Rmtcfg (TAB Select) <Enable>: Enable_

-----

<I/K> Move up/down, <J/L> Exit/Enter, <U/O> Move top/bottom
```

5.4.8. Restore factory default

The G.SHDSL .Bis NTU can restore all settings to the original factory settings simply by going to the setting menu, selecting the Default item, and then press ENTER. The system will ask for a y(es) or n(o) confirmation followed by an ENTER.

```

CH A                               SHDSL .BIS NTU
-----
Interface                          Configure NTU Interface
Shdsl                               Configure SHDSL Parameters
Ethernet                            Configure Ethernet Parameters
Rmtcfg                              Enable/Disable Remote Config
>> Default                          Restore NTU's Default Setting

-----

Command:Default <CR>
Message: Please input the following information.

Are you sure? (y/n): y

-----

<I/K> Move up/down, <J/L> Exit/Enter, <U/O> Move top/bottom

```

The default values are in the following table:

Interface	Setup Parameter	Default value
SHDSL	setup Interface	E1 <i>*Notes 1*</i>
	setup Shdsl Mode	STU-R
	setup Shdsl Annex	Annex-G
	setup Shdsl Psd	SYM
	setup Shdsl Startup Margin	0
	setup Shdsl Pair Mode	1 Pair <i>*Notes 2*</i>
E1	setup E1 Channel	PCM31C
	setup Pass Through	Off
	setup E1 Slot Number	31
	setup E1 First Slot	1
	setup E1 code	HDB3
	setup E1 AIS	Off
	setup E1 Build Outs	120 Ohm
Serial	setup Serial Interface	V35
	setup Serial Data Rate Type	Nx64K
	setup Serial Data Rate	32
	setup Serial Clock	normal
	setup Serial Rts	on
	setup Serial Cts	from_rts
	setup Serial Dsr	on
	setup Serial Dcd	from_dsl
setup Serial Delay	3	

Ethernet	Setup Ethernet Rate Type Setup Ethernet Rate setup Ethernet Auto Config setup Ethernet Speed setup Ethernet Duplex	Nx64K 36 Enable Auto negotiate Auto negotiate
E1+ Serial	setup E1 Channel setup E1 Slot Number setup E1 First Slot setup E1 code setup E1 AIS setup E1 Build Outs setup Serial Interface setup Serial Data Rate Type setup Serial Data Rate setup Serial Clock setup Serial Rts setup Serial Cts setup Serial Dsr setup Serial Dcd setup Serial Delay	PCM31C 31 1 HDB3 Off 120 Ohm V35 Nx64K 32 normal on from_rts on from_dsl 3
E1+Ethernet	setup E1 Channel setup E1 Slot Number setup E1 First Slot setup E1 code setup E1 AIS setup E1 Build Outs Setup Ethernet Rate Type Setup Ethernet Rate setup Ethernet Auto Config setup Ethernet Speed setup Ethernet Duplex	PCM31C 31 1 HDB3 Off 120 Ohm Nx64K 36 Enable Auto negotiate Auto negotiate
T1	setup T1 Channel setup T1 Slot Number setup T1 First Slot setup T1 AIS setup T1 Lbo	SF 24 1 off 0 to 133ft

T1+ Serial	setup T1 Channel setup T1 Slot Number setup T1 First Slot setup T1 AIS setup T1 Lbo setup Serial Interface setup Serial Data Rate Type setup Serial Data Rate setup Serial Clock setup Serial Rts setup Serial Cts setup Serial Dsr setup Serial Dcd setup Serial Delay	SF 24 1 Off 0 to 133ft V35 Nx64K 32 normal on from_rts on from_dsl 3
T1+ Ethernet	setup T1 Channel setup T1 Slot Number setup T1 First Slot setup T1 AIS setup T1 Lbo setup Ethernet Rate Type setup Ethernet Rate setup Ethernet Auto Config setup Ethernet Speed setup Ethernet Duplex	SF 24 1 Off 0 to 133ft Nx64K 36 Enable 100M Full-Duplex

Notes1 For Multi-interface models only (SHDTU03b-31, SHDTU02bA-31, SHDTU03b-31T and SHDTU03bA-31T)

Notes 2 For 2 pairs (4-wires) model only (SHDTU03bA-E1, SHDTU03bA-E1/T1, SHDTU03bA-Data, SHDTU03bA-ET100, SHDTU03bA-31 and SHDTU03bA-31T)

5.5 Reboot

In main menu, move the cursor to **reboot** and press [ENTER]. The device will reboot after confirming.

```
SHDSL.BIS NTU
-----
setup          Configure system
status         Show running system status
show           View system configuration
>> reboot      Reset and boot system
diag           Diagnostic utility
upgrade        Console software upgrade
exit           Quit system

-----

Command:reboot <CR>
Message:

-----

<I/K> Move up/down, <J/L> Exit/Enter, <U/O> Move top/bottom
```

```
SHDSL.BIS NTU
-----
setup          Configure system
status         Show running system status
show           View system configuration
>> reboot      Reset and boot system
diag           Diagnostic utility
upgrade        Console software upgrade
exit           Quit system

-----

Command:reboot <CR>
Message: Please input the following information.

Do you want to reboot? (y/n): y
00800000 Ram Ok

-----

<I/K> Move up/down, <J/L> Exit/Enter, <U/O> Move top/bottom
```

After the reboot operation has finished, RAM test will start.

5.6 View the system status

You can use the status command to view the status of SHDSL, E1, Serial and Ethernet as well as statistic and clear the statistic log. Select **status** and press [ENTER].

```
SHDSL.BIS NTU
-----
  setup          Configure system
>> status       Show running system status
  show           View system configuration
  write          Update flash configuration
  reboot         Reset and boot system
  diag           Diagnostic utility
  upgrade        Console software upgrade
  exit           Quit system
-----
Command:status <more...> _
Message:
-----
<I/K> Move up/down, <J/L> Exit/Enter, <U/O> Move top/bottom
```

5.6.1. View the SHDSL status

Select **SHDSL** command to show the status of SHDSL.

```
SHDSL.BIS NTU
-----
>> Shdsl        Show SHDSL.BIS Status
  Interface      Show Interface Status
  Loc_statistics Show Local Statistics
  Rmt_statistics Show Remote Statistics
  clear          Clear Channel Statistics
-----
Command:Shdsl <CR>
Message:
-----
<I/K> Move up/down, <J/L> Exit/Enter, <U/O> Move top/bottom
```

```

-----
SHDSL.BIS NTU
-----
<Shdsl Status>
Channel          :          LocA          RmtA
STU Type        :   STU-C-INTCLK        STU-R
DSL Type        :          SHDSL.BIS      SHDSL.BIS
Line Rate(Kbps) :          2304          2304
SNR Margin (dB) :          26.0          26.0
Attenuation(dB) :          2.0           3.0

Led On/Off Status :          0006          0016
Led Flash Status  :          0000          0000

Loopback State   :          Disable      Disable
Bert Test State  :          Disable      Disable
Bert Sync        :          Not Sync     Not Sync
Bert Error Count :          0            0

Refresh counter:4, Press 'Ctrl+C' to quit...

-----
<I/K> Move up/down, <J/L> Exit/Enter, <U/O> Move top/bottom
-----

```

The SHDSL status will display a real-time status of the DSL on local side and remote side if connected. The monitoring window displays the DSL line parameters, such as SNR margin and attenuation. The lower half of the window displays the loopback and BER test status. While in this display mode the terminal window will not timeout. To exit the window, press CTRL-C to quit.

5.6.2. View the Interface status

Select **Interface** command to show the status of Interface

```

-----
SHDSL.BIS NTU
-----
Shdsl          Show SHDSL Status
>> Interface   Show Interface Status
Current Perf    Show Current Performance
Loc_statistics  Show Local Statistics
Rmt_statistics  Show Remote Statistics
clear          Clear Channel Statistics

-----
Command:Interface <CR> _
Message:

-----
<I/K> Move up/down, <J/L> Exit/Enter, <U/O> Move top/bottom
-----

```

```

-----
                                SHDSL.BIS NTU
-----
Channel           :           LocA           RmtA
STU Type         :   STU-C-INTCLK         STU-R
Interface        :           E1             E1
E1 DataRate(Kbps) :           960         960
E1 Sync         :           Down          Down
E1 AIS Alarm     :           Off          Off

Serial DataRate(Kbps):
Serial DCD      :
Serial DSR      :
Serial CTS      :
Serial RTS      :
Serial DTR      :

Eth DataRate(Kbps) :
Eth Link        :
Eth Speed       :
Eth Duplex      :
Refresh counter:2, Press 'Ctrl+C' to quit..._
-----
<I/K> Move up/down, <J/L> Exit/Enter, <U/O> Move top/bottom

```

The interface status will display a real-time status of the interface on local side and remote side if connected. The monitoring window displays the STU type, interface mode, status on E1, Serial and Ethernet. While in this display mode the terminal window will not timeout. To exit the window, press CTRL-C to quit.

The table of SHDSL line rate vs. data rate:

SHDSL Line rate	Data Rate (kbps)	
	Number of time slot for E1	Nx64K for Serial and Ethernet
5696(n=89)	Cannot use	89
5632(n=88)	Cannot use	88
5568(n=87)	Cannot use	87
.....
.....
.....
.....
2368(n=37)	Cannot use	37
2304(n=36)	Cannot use	36
2240(n=35)	Cannot use	35
2176(n=34)	Cannot use	34
2112(n=33)	Cannot use	33
2048(n=32)	32(unframed)	32
1984(n=31)	31	31
1920(n=30)	30	30
1856(n=29)	29	29
1792(n=28)	28	28
.....
.....
.....
.....
384(n=6)	6	6
320(n=5)	5	5
256(n=4)	4	4
192(n=3)	3	3
192(n=3)	2	2
192(n=3)	1	1

Because standard SHDSL.bis working DSL line rate starts up from 192kbps (n=3), all settings on all interfaces with apply 64kbps(n=1) and 128kbps(n=2) will actually be using 192kbps DSL line rate.

The above table applies to Annex F and G. When using Annex A and B, there are no N values greater than 36.

5.6.3. View the Statistics

Select **Loc_statistics** command to show the Local statistics information in 15 minutes or 24 hour via [TAB] to choose.

```
SHDSL.BIS NTU
-----
Shdsl          Show SHDSL.BIS Status
Interface      Show Interface Status
>> Loc_statistics Show Local Statistics
Rmt_statistics Show Remote Statistics
clear         Clear Channel Statistics

-----

Command:Loc_statistics <CR>
Message: Please input the following information.

Shdsl Channel Statistics (TAB Select) <15m>: 15m_

-----

<I/K> Move up/down, <J/L> Exit/Enter, <U/O> Move top/bottom
```

The statistics display window will display performance monitor data for the selected interval (15 minutes or 24 hours). The display will show the recorded results for ES (errored seconds), SES (severely errored seconds), UAS (unavailable seconds), and LOSW (loss of sync word). While in this display mode the terminal window will not timeout. The 15 minute display window will display all the performance information for each 15 minutes interval in the current 24 hours period. There are a total of 96 15 minute intervals in a 24 hour period. Press the ENTER key to display the next page of intervals. To exit the window, press CTRL-C and then ENTER.

The performance monitor is capable of storing and retrieving performance information for each 24 hours interval, up to 7 days.

For E1 Interface model, there are SHDSL and E1 items.

View the performance monitor data for the selected interval 15 minutes:

SHDSL . BIS NTU							
Local	SHDSL				E1		
15 Minute	ES	SES	UAS	LOSW	ES	SES	UAS
Current	0	0	0	0	0	0	2
Quarter 1	0	0	0	0	0	0	0
Quarter 2	0	0	0	0	0	0	0
Quarter 3	0	0	0	0	0	0	0
Quarter 4	0	0	0	0	0	0	0
Quarter 5	0	0	0	0	0	0	0
Quarter 6	0	0	0	0	0	0	0
Quarter 7	0	0	0	0	0	0	0
Quarter 8	0	0	0	0	0	0	0
Quarter 9	0	0	0	0	0	0	0
Quarter 10	0	0	0	0	0	0	0
Quarter 11	0	0	0	0	0	0	0
Quarter 12	0	0	0	0	0	0	0
Quarter 13	0	0	0	0	0	0	0
Quarter 14	0	0	0	0	0	0	0
More <CR>							

<I/K> Move up/down, <J/L> Exit/Enter, <U/O> Move top/bottom

View the performance monitor data for the selected interval 7days:

SHDSL . BIS NTU							
Local	SHDSL				E1		
24 Hour	ES	SES	UAS	LOSW	ES	SES	UAS
Current	0	0	0	0	0	0	53
Day 1	0	0	0	0	0	0	0
Day 2	0	0	0	0	0	0	0
Day 3	0	0	0	0	0	0	0
Day 4	0	0	0	0	0	0	0
Day 5	0	0	0	0	0	0	0
Day 6	0	0	0	0	0	0	0
Day 7	0	0	0	0	0	0	0

Press any key to Return Menu Window..._

<I/K> Move up/down, <J/L> Exit/Enter, <U/O> Move top/bottom

For Serial and Ethernet Interface model, there is only the SHDSL item.
View the performance monitor data for the selected interval 15 minutes:

SHDSL .BIS NTU				
Local	SHDSL			
15 Minute	ES	SES	UAS	LOSW
Current	0	0	0	0
Quarter 1	0	0	0	0
Quarter 2	0	0	0	0
Quarter 3	0	0	0	0
Quarter 4	0	0	0	0
Quarter 5	0	0	0	0
Quarter 6	0	0	0	0
Quarter 7	0	0	0	0
Quarter 8	0	0	0	0
Quarter 9	0	0	0	0
Quarter 10	0	0	0	0
Quarter 11	0	0	0	0
Quarter 12	0	0	0	0
Quarter 13	0	0	0	0
Quarter 14	0	0	0	0
More <CR>				

<I/K> Move up/down, <J/L> Exit/Enter, <U/O> Move top/bottom				

View the performance monitor data for the selected interval 7 days:

SHDSL .BIS NTU				
Local	SHDSL			
24 Hour	ES	SES	UAS	LOSW
Current	0	0	0	0
Day 1	0	0	0	0
Day 2	0	0	0	0
Day 3	0	0	0	0
Day 4	0	0	0	0
Day 5	0	0	0	0
Day 6	0	0	0	0
Day 7	0	0	0	0
Press any key to Return Menu Window..._				

<I/K> Move up/down, <J/L> Exit/Enter, <U/O> Move top/bottom				

When clear the statistic log file, select **clear** and press [ENTER].

```
SHDSL.BIS NTU
-----
Shdsl          Show SHDSL.BIS Status
Interface      Show Interface Status
Loc_statistics Show Local Statistics
Rmt_statistics Show Remote Statistics
>> clear       Clear Channel Statistics

-----

Command:clear <CR> _
Message:

-----

<I/K> Move up/down, <J/L> Exit/Enter, <U/O> Move top/bottom
```

If you want to show the remote side's statistics, please use the Rmt-statistics function as the following.

```
SHDSL.BIS NTU
-----
Shdsl          Show SHDSL.BIS Status
Interface      Show Interface Status
Loc_statistics Show Local Statistics
>> Rmt_statistics Show Remote Statistics
clear          Clear Channel Statistics

-----

Command:Loc_statistics <CR>
Message: Please input the following information.
Shdsl Channel Statistics (TAB Select) <15m>: 15m.

-----

<I/K> Move up/down, <J/L> Exit/Enter, <U/O> Move top/bottom
```

The following are commonly used acronyms:

ES	Number of errored seconds in which one or more CRC (Cyclic Redundancy Check) error events occurred during the current interval. This value is updated every second.
UAS	Number of unavailable seconds in which a failed signal occurred during the current interval. This value is updated every second.
SES	Number of severely errored seconds in which 832 or more CRC error events occurred during the current interval. This value is updated every second.
LOSW	Number of seconds with loss of sync word during the current interval. This value is updated every second.

5.7 View System Configuration

By using show command, you can view the system configuration. Select **show** and press [ENTER] or [RIGHT].

```
-----
                                SHDSL.BIS NTU
-----
  setup          Configure system
  status         Show running system status
>> show         View system configuration
  reboot        Reset and boot system
  diag          Diagnostic utility
  upgrade       Console software upgrade
  exit          Quit system

-----

Command:show <more...> _
Message:

-----

<I/K> Move up/down, <J/L> Exit/Enter, <U/O> Move top/bottom
```

5.7.1 Show system Information

To show system information, please select **system** and press [ENTER] or [RIGHT]. The screen will prompt the system information.

```
-----
                                SHDSL.BIS NTU
-----
>> System       Show General Information
  Config        Show Configuration
  Script        Show Configuration in Command Script

-----

Command:System <CR> _
Message:

-----

<I/K> Move up/down, <J/L> Exit/Enter, <U/O> Move top/bottom
```

Our cursor is already on the **System** command, so press ENTER and the following screen will display the general system information.

```
SHDSL.BIS  NTU
-----
<System Info Window>

          Local Side          Remote Side
          =====          =====
Model      : 5099B-4W/E1/T1/SER/ETH
Sw Version : 1.14.8
FPGA Version: 1.30
CPU        : Winbond W90N740
RAM        : 8MB
FLASH      : 2MB
Dsp Version : 1.1-1.5.5_003
SerialNo   : CKPKF2UA0099
System MCSV : 14D2-0000-11416201
Kernel MCSV : 14D2-0000-114DBEC5
FPGA MCSV  : 14D2-0000-130161EA

System Live Time : 0 Day/ 0Hour/ 7Min /17 Secs

-----
<I/K> Move up/down, <J/L> Exit/Enter, <U/O> Move top/bottom
```

Most of the information on this screen is either self-explanatory or it is simply irrelevant for the end user. However, two items, the Kernel (Software) and FPGA (Field Programmable Gate Array) version will give the software and hardware versions respectively of NTU. These are important to know in case new firmware becomes available in the future to add extra functions of fixing unknown bugs from the original manufactured equipment.

5.7.2. Show system with listing format

To show the system configuration, please select **Config** and press [ENTER] or [RIGHT]. The screen will prompt the all configuration data.

For E1 interface mode:

```
----- SHDSL.BIS NTU -----
Showing System Configuration...
setup Interface      :      E1
setup Type           :      STU-R
setup Shdsl Annex    :      Annex-G
setup Shdsl Psd      :      SYM
setup Shdsl Margin   :      0
setup Shdsl Pair Mode :      1 Pair
setup E1 Channel     :      PCM30
setup E1 Pass Through :      Off
setup E1 Slot Number :      30
setup E1 First Slot  :      1
setup E1 Code        :      HDB3
setup E1 AIS         :      Off
setup E1 Build Outs  :      120 Ohm

Press any key to Return Menu Window..._
```

For Serial interface mode:

```
----- SHDSL.BIS NTU -----
Showing System Configuration...
setup Interface      :      Serial
setup Type           :      STU-R
setup Shdsl Annex    :      Annex-G
setup Shdsl Psd      :      SYM
setup Shdsl Margin   :      0
setup Serial Interface :      V35
setup Serial Data Rate :      32
setup Serial Clock    :      normal
setup Serial Rts      :      on
setup Serial Cts      :      from_rts
setup Serial Dsr      :      on
setup Serial Dcd      :      from_dsl
setup Serial Delay    :      3
Press any key to Return Menu Window...
```

For Ethernet interface mode:

```
-----  
SHDSL.BIS NTU  
-----  
Showing System Configuration...  
setup Interface      : Ethernet  
setup Type           : STU-R  
setup Shdsl Annex    : Annex-G  
setup Shdsl Psd      : SYM  
setup Shdsl Margin   : 0  
setup Ethernet Auto Config : Enable  
setup Ethernet Speed : 100M  
setup Ethernet Duplex : Full-Duplex  
setup Ethernet Rate  : 36  
Press any key to Return Menu Window...
```

For E1 and Serial interface mode:

```
-----  
SHDSL.BIS NTU  
-----  
Showing System Configuration...  
setup Interface      : E1+Serial  
setup Type           : STU-R  
setup Shdsl Annex    : Annex-G  
setup Shdsl Psd      : SYM  
setup Shdsl Margin   : 0  
setup E1 Channel     : PCM31C  
setup E1 Slot Number : 31  
setup E1 First Slot  : 1  
setup E1 Code        : HDB3  
setup E1 AIS         : Off  
setup E1 Build Outs  : 120 Ohm  
setup Serial Interface : V35  
setup Serial Data Rate : 32  
setup Serial Clock   : normal  
setup Serial Rts     : on  
setup Serial Cts     : from_rts  
setup Serial Dsr     : on  
setup Serial Dcd     : from_dsl  
setup Serial Delay   : 3  
Press any key to Return Menu Window...
```

For E1 and Ethernet interface mode:

```
----- SHDSL .BIS NTU -----
Showing System Configuration...
setup Interface      : E1+Ethernet
setup Type           : STU-R
setup Shdsl Annex   : Annex-G
setup Shdsl Psd     : SYM
setup Shdsl Margin  : 0
setup E1 Channel    : PCM31C
setup E1 Slot Number : 31
setup E1 First Slot : 1
setup E1 Code       : HDB3
setup E1 AIS        : Off
setup E1 Build Outs : 120 Ohm
setup Ethernet Auto Config : Enable
setup Ethernet Speed : 100M
setup Ethernet Duplex : Full-Duplex
setup Ethernet Rate  : 36
Press any key to Return Menu Window...
```

5.7.3. Show system with script format

To show the system script file, please select **Script** and press [ENTER] or [RIGHT]. The screen will prompt the configuration in script type.

```
----- SHDSL .BIS NTU -----
System          Show General Information
Config          Show Configuration
>> Script       Show Configuration in Command Script

-----
Command:Script <CR>
Message:

-----
<I/K> Move up/down, <J/L> Exit/Enter, <U/O> Move top/bottom
```

For E1 interface mode:

```
-----  
SHDSL.BIS NTU  
-----  
<Script Window>  
  
setup mode STU-R  
setup Shdsl Interface E1  
setup Shdsl Annex Annex-G  
setup Shdsl Psd SYM  
setup Shdsl Margin 0  
setup E1 Channel PCM31C 31  
setup E1 code HDB3  
setup E1 ais Off  
setup E1 build_outs 120 Ohm  
Press any key to Return Menu Window...
```

For Serial interface mode:

```
-----  
SHDSL.BIS NTU  
-----  
<Script Window>  
  
setup mode STU-R  
setup Shdsl Interface Serial  
setup Shdsl Annex Annex-G  
setup Shdsl Psd SYM  
setup Shdsl Margin 0  
setup Serial Interface V35  
setup Serial Data Rate 32  
setup Serial Clock normal  
setup Serial Rts on  
setup Serial Cts from_rts  
setup Serial Dsr on  
setup Serial Dcd from_dsl  
setup Serial Delay 3  
Press any key to Return Menu Window..._
```

For Ethernet interface mode:

```
-----  
SHDSL.BIS NTU  
-----  
<Script Window>  
  
setup mode STU-R  
setup Shdsl Interface E1  
setup Shdsl Annex Annex-G  
setup Shdsl Psd SYM  
setup Shdsl Margin 0  
setup E1 Channel PCM31C 31  
setup E1 code HDB3  
setup E1 ais Off  
setup E1 build_outs 120 Ohm  
Press any key to Return Menu Window..._
```

For E1 + Serial interface mode:

```
-----  
SHDSL.BIS NTU  
-----  
<Script Window>  
  
setup mode STU-R  
setup Shdsl Interface E1+Serial  
setup Shdsl Annex Annex-G  
setup Shdsl Psd SYM  
setup Shdsl Margin 0  
setup E1 Channel PCM31C 31  
setup E1 code HDB3  
setup E1 ais Off  
setup E1 build_outs 120 Ohm  
setup Serial Interface V35  
setup Serial Data Rate 32  
setup Serial Clock normal  
setup Serial Rts on  
setup Serial Cts from_rts  
setup Serial Dsr on  
setup Serial Dcd from_dsl  
setup Serial Delay 3  
Press any key to Return Menu Window..._
```

For E1 + Ethernet interface mode:

```
SHDSL.BIS NTU
-----
<Script Window>
setup mode STU-R
setup Shdsl Interface E1+Ethernet
setup Shdsl Annex Annex-G
setup Shdsl Psd SYM
setup Shdsl Margin 0
setup E1 Channel PCM31C 31
setup E1 code HDB3
setup E1 ais Off
setup E1 build_outs 120 Ohm
setup Ethernet Rate 36
setup Ethernet Auto Enable
setup Ethernet Duplex Full-Duplex
setup Ethernet Speed 100M
Press any key to Return Menu Window..._
```

5.8 Upgrade

This section will introduce how to upgrade the kernel and FPGA code of G.SHDSL .Bis NTU. Select **upgrade** in main menu and press [ENTER] or [RIGHT].

Please notice that when you use Remote Upgrade feature. It means you can use that feature to update firmware to remote side. It will be described below.

During an upgrade and re-flash, the normal transmissions will be halted, so the upgrade should be done when the system is taken offline or done during a time of extremely low impact to the line of customer.

The upgrade procedures use the Xmodem protocol via the serial console port of rear panel.

Following shows how to select the upgrade feature:

```
SHDSL.BIS NTU
-----
setup          Configure system
status         Show running system status
show           View system configuration
write          Update flash configuration
reboot        Reset and boot system
diag          Diagnostic utility
>> upgrade    Console software upgrade
exit           Quit system

-----

Command:upgrade <more...>
Message:

-----

<I/K> Move up/down, <J/L> Exit/Enter, <U/O> Move top/bottom
```

Before upgrading the NTU, you must have the main software or FPGA code in your computer.

If you want to upgrade the kernel code: select **Kernel** and press [ENTER] or [RIGHT].

```
SHDSL.BIS NTU
-----
>> Kernel      Upgrade main software
Fpga           Upgrade FPGA code
Rmt Kernel     Upgrade the remote's main software
Rmt FPGA       Upgrade the remote's FPGA code

-----

Command:Kernel <CR> _
Message:

-----

<I/K> Move up/down, <J/L> Exit/Enter, <U/O> Move top/bottom
```

Click Send file in terminal access program, hyper terminal, to send the file. Make sure the sending protocol is **Xmodem**.

Select the source file in shown window and then press OK.

During the upgrade, you can see the following:

```
SHDSL.BIS NTU
-----
Starting XModem Upload..CCCCCCCCCCCCCCCCCC_

-----
<I/K> Move up/down, <J/L> Exit/Enter, <U/O> Move top/bottom
```

If you want to upgrade the FPGA code: Select **FPGA** and press [ENTER] or [RIGHT].

```
SHDSL.BIS NTU
-----
Kernel          Upgrade main software
>> Fpga         Upgrade FPGA code
Rmt Kernel      Upgrade the remote's main software
Rmt FPGA       Upgrade the remote's FPGA code

-----
Command:Fpga <CR> _
Message:

-----
<I/K> Move up/down, <J/L> Exit/Enter, <U/O> Move top/bottom
```

During the upgrade process, you will see the following:

```
SHDSL.BIS NTU
-----
Starting XModem Upload...CCC_

-----
<I/K> Move up/down, <J/L> Exit/Enter, <U/O> Move top/bottom
```

Below shows the remote upgrade feature:

```
SHDSL.BIS NTU
-----
Kernel          Upgrade main software
Fpga            Upgrade FPGA code
>> Rmt Kernel   Upgrade the remote's main software
Rmt FPGA       Upgrade the remote's FPGA code

-----
Command:Rmt Kernel <CR> _
Message:

-----
<I/K> Move up/down, <J/L> Exit/Enter, <U/O> Move top/bottom
```

During the upgrade, the display will look like the following:

```
SHDSL .BIS NTU
-----
Starting XModem Upload...CCC_

-----
<I/K> Move up/down, <J/L> Exit/Enter, <U/O> Move top/bottom
```

Before upgrading the NTU, you must have the Kernel code and FPGA code on your computer's hard drive.

WARNING!!: Do not allow any interruption of power during the erase and re-write operation or the Flash will be left in an unknown state and the device will no longer be able to function. The device must then be returned to the factory for repair.

5.9 Diagnostic

The diagnostic facility allows you to test the different aspects of your G.SHDSL .Bis NTU to determine if it is working properly. Select **diag** and press [ENTER] or [RIGHT].

```
SHDSL.BIS NTU
-----
  setup          Configure system
  status         Show running system status
  show          View system configuration
  reboot        Reset and boot system
>> diag        Diagnostic utility
  upgrade       Console software upgrade
  exit          Quit system
-----

Command:diag <more...>
Message:

-----

<I/K> Move up/down, <J/L> Exit/Enter, <U/O> Move top/bottom
```

Loopback can test whether if the NTU is working properly with the connected device.

Press [ENTER] or [RIGHT] to setup the loopback.

```
SHDSL.BIS NTU
-----
>> Loopback     Execute Loopback
  BerTest       Execute Local Ber Test
-----

Command:Loopback <CR>
Message: Please input the following information.

Change Loopback (TAB Select) <Disable>: Local Digital_

-----

<I/K> Move up/down, <J/L> Exit/Enter, <U/O> Move top/bottom
```

For E1/T1 Interface model at CO side, there are loopbacks for: Local Digital, local, remote line, remote payload, farend line and farend payload.

For Serial Interface model at CO side, there are loopbacks for: Local Digital, local, remote line, remote payload, farend line, farend payload and V.54.

For E1/T1 Interface model at CPE side, there are loopbacks for: Local Digital, remote line, remote payload, farend line and farend payload.

For Serial Interface model at CPE side, there are loopbacks for: Local Digital, remote line, remote payload, farend line, farend payload and V.54.

If the device has just been connected or the DSL is still under handshaking, there will not be far end line, far end payload and V.54. There are no diagnostic functions on Ethernet interface model as Ethernet that is looped back would cause a broadcast storm.

Stand alone NTU, no connection with other NTU:

E1/T1 interface CO side	Serial interface CO side
Local Digital	Local Digital
Local	Local
Remote line	Remote line
Remote payload	Remote payload

E1/T1 interface CPE side	Serial interface CPE side
Local Digital	Local Digital
Remote line	Remote line
Remote payload	Remote payload

After connection both CO side and CPE side:

E1/T1 interface CO side	Serial interface CO side
Local Digital	Local Digital
Local	Local
Remote line	Remote line
Remote payload	Remote payload
Far end line	Far end line
Far end payload	Far end payload
	V.54

E1/T1 interface CPE side	Serial interface CPE side
Local Digital	Local Digital
Remote line	Remote line
Remote payload	Remote payload
Far end line	Far end line
Far end payload	Far end payload
	V.54

About **V.54** : An ITU standard (1976) for various loopback tests which can be incorporated into modems for testing the telephone circuit and isolating transmission problems. Operating modes include local and remote digital loopback and local and remote analog loopback.

The SHDSL.bis NTU supports Bit Error Rate Testing (BERT). To configure the BERT, move the cursor to **BerTest** and press [ENTER] or [RIGHT].

```

SHDSL .BIS NTU
-----
  Loopback          Execute Loopback
>> BerTest         Execute Local Ber Test

-----

Command:BerTest <CR>
Message: Please input the following information.

BerTest Type (TAB Select) <2047>: 2047_

-----

<I/K> Move up/down, <J/L> Exit/Enter, <U/O> Move top/bottom

```

The BER Test screen is as following:

```

SHDSL .BIS NTU
-----
Monitoring Window...BER Test

Test Pattern      :      2047
Time Elapsed     :          8
Pattern Sync     :      Sync
Bit Error Count  :          0

Refresh counter:5, Press 'Ctrl+C' to quit...

-----

<I/K> Move up/down, <J/L> Exit/Enter, <U/O> Move top/bottom

```

The G.SHDSL Bis NTU includes an internal Bit Error Rate Tester (BERT) for complete testing of local and remote modem and the link quality without any need for any external test equipment. This built-in Bit Error Rate Test generator can generate a standard 2047 ($2^{11}-1$) test pattern.

Test Pattern: 2047	Use the standard 2047 ($2^{11}-1$) test pattern
Time Elapsed	Shows the time elapsed count
Pattern Framing	Shows the linking is sync or no sync
Bit Error Count	Shows the bit error counter
Refresh counter	Page refresh counter

You can press CTRL-C to quit this page anytime.

About 2047 ($2^{11}-1$) test pattern: This is the pseudorandom sequence, based on an eleven (11) bit shift register, a pseudorandom pattern with a maximum of 10 sequential zeros and 11 sequential ones.

5.10 Exit

For exiting the system without saving any configuration, you can use **exit** command to exit. Select **exit** and press [ENTER] or [RIGHT]. Answer y(es) to confirm.

```
-----
                                SHDSL.BIS NTU
-----
  setup          Configure system
  status         Show running system status
  show           View system configuration
  reboot         Reset and boot system
  upgrade        Console software upgrade
>> exit         Quit system

-----

Command:exit <CR>
Message: Please input the following information.

Do you want to disconnect? (y/n):

-----

<I/K> Move up/down, <J/L> Exit/Enter, <U/O> Move top/bottom
```

After pressing [ENTER], the system will be disconnected.

```
Connection closed...
Press Space key to enter console mode configuration!
```

When the system has been disconnected, user can see the close screen. You can press Space key to restart.

```
User: admin  
Password: *****_
```

The new login screen will be shown again, you can type username and password again to enter.

6. Appendix

6.1 Abbreviations

AIS	Alarm Indication Signal
AMI	Alternate mark inversion
ASYM	Asymmetric
ATM	Asynchronous Transfer Mode
B8ZS	Bipolar with 8 zero substitution
BER	Bit error rate
BERT	Bit Error Rate Tester
BNC	Bayonet Neill-Concelman (a common RF connector for coaxial cable)
bps	Bits per second
CAS	Channel Associated Signaling
CEPT	European Conference of Postal and Telecommunications Administrations.
CERR	CRC Errors
CO	Central Office
CPE	Customer Premises Equipment
CPU	Central processing unit
CRC	Cyclic redundancy check
CRC4	Cyclic redundancy check 4 bit
CRS	Carrier Sense
CSU	Channel service unit
CTS	Clear to send
DCD	Data carrier detect
DCE	Data communication equipment
DSL	Digital subscriber loop
DSR	Data set ready
DSLAM	DSL Access Multiplexer
DTE	Data terminal equipment
DTR	Data terminal ready
E BIT GEN	Remote End Block Error Bit generation
EOC	Embedded operations channel
ES	Number of Error second (Errors/Second)
ESF	Extended super frame
ETSI	European Telecommunications Standardization Institute
FAS	Frame alignment signal
FCS	Frame Check Sequence
HDB3	High-Density Bipolar of order 3
HDLC	High-Level Data Link Control
HEC	Header error check

I/F	Interface
ITU	International Telecommunication Union
ITU-T	ITU-Telecommunication Standardization Sector
LBO	Line Build Out
LIU	Line Interface Unit
LOC	Loss of Connection
LOF	Loss of frame
LOS	Loss of signal
LOSW	Loss of synchronization word
LTU	Line Termination Unit
MAS	Multi-frame Alignment Sequence (CAS Format)
MFAS	Multi-frame Alignment Sequence (CRC4 Format)
MHz	MegaHertz
NI	Network Interface
NRZ	Non-Return to Zero
NTU	Network Termination Unit
PABX	Private Automatic Branch Exchange
PAM	Pulse Amplitude Modulation
PLL	Phase-locked loop
POTS	Plain Old Telephone Service
PRBS	Pseudo-Random Bit Sequence
PSD	Power spectral density
QRSS	Quasi-Random Signal Source
RAI	Remote alarm indication
RESYNC	Resynchronization
RJ-45	Registered Jack-45
RTS	Request to send
RX	Receiver
SES	Number of Severely error seconds (more than 832 CRC errors / second. Approximately equivalent to a bit error rate of 1×10^{-3})
SDLC	Synchronous data Link Control
SF	Super Frame
SHDSL	Symmetric High-Bitrate Digital Subscriber Loop
SLC	Subscriber Loop Carrier
SMF	Sub-Multi frame
SNA	System Network Architecture
SNR MARGIN	Signal to noise ration margin
STU	SHDSL Terminal Unit
STU-C	SHDSL Terminal Unit - Central office side
STU-R	SHDSL Terminal Unit - Remote side
STU-C-INTCLK	STU-C internal clock

STU-R-EXTCLK	STU-R external clock
SYM	Symmetric
SYNC	Synchronization
TC-PAM	Trellis Coded Pulse Amplitude Modulation
TDM	Time Division Multiplexing
TPS-TC	Transmission Protocol Specific TC layer
TX	Transmitter
Tx Power	Transmission power
UAS	Unavailable second
UI	User interface
WAN	Wide Area Network
xDSL	"Any" DSL , (ADSL , HDSL ,SHDSL or VDSL etc)

6.2 Serial Interface Pin Assignments

The table below displays Serial Interface Pin Assignments for the DCE Mode

Function	Abbrev.	Direction	RS-530 DB-25(F)	V.35 M.34(F)	X.21 DB-15(F)
Frame Ground	FG	N/A	1	A	1
Transmit Data	TD	Input	2	P	2
Receive Data	RD	Output	3	R	4
Request to Send	RTS	Input	4	C	3
Clear to Send	CTS	Output	5	D	
Data Set Ready	DSR	Output	6	E	
Signal Ground	SG	N/A	7	B	8
Data Carrier Detect	DCD	Output	8	F	5
Secondary Receiver Clock	(S)RC	Output	9	X	13
Secondary Data Carrier Detect	(S)DCD	Output	10		12
Secondary External Transmitter Clock	(S)ETC	Input	11	W	7
Secondary Transmitter Clock	(S)TC	Output	12	AA	
Secondary Clear to Send	(S)CTS	Output	13		
Secondary Transmit Data	(S)TD	Input	14	S	9
Transmitter Clock	TC	Output	15	Y	
Secondary Receive Data	(S)RD	Output	16	T	11
Receiver Clock	RC	Output	17	V	6
Local Loopback			18		
Secondary Request to Send	(S)RTS	Input	19		10
Data Terminal Ready	DTR	Input	20	H	
Remote Loopback			21		
Secondary Data Set Ready	(S)DSR	Output	22		
Secondary Data Terminal Ready	(S)DTR	Input	23		
External Transmitter Clock	ETC	Input	24	U	14
Test Indicator			25		

The front view of DB-25(F) Serial interface connector on rear panel:

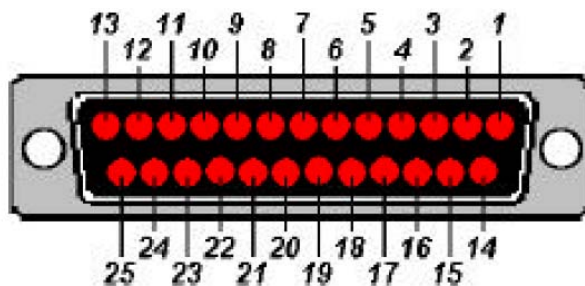

DB-25(F) Connector

6.3 V.35 DB25(M) to M.34(F) adaptor Cable

If the DTE (Data Terminal Equipment) connector is using 34-pin Winchester type, we must use the cable adaptor from DB-25 to Winchester (M.34).

The pin out of cable on DB-25(male) Connector to M.34(female) Connector:

DB-25 Pin	Signal	M.34 Pin	Description
2	TD	P	Transmit Data
14	TD	S	Transmit Data
3	RD	R	Receive Data
16	RD	T	Receive Data
4	RTS	C	Ready To Send
5	CTS	D	Clear To Send
6	DSR	E	Data Set Ready
20	DTR	H	Data Terminal Ready
24	XTC	U	DTE Transmit Clock
11	XTC	W	DTE Transmit Clock
15	TC	Y	Transmit Clock
12	TC	AA	Transmit Clock
17	RC	V	Receive Clock
9	RC	X	Receive Clock
1	FGND	A	Protective Ground
7	GND	B	Signal Ground
8	DCD	F	Data Carrier Detect

V.35 is a partially balanced, partially single-ended interface specification. The data leads and clock leads are balanced; the handshake leads are single-ended.

TD, RD, TC, RC and XTC are differential signals which conform to RS-422/V.11. Remaining unbalanced control and handshake signals (RTS, CTS, DSR and DTR) conform to RS-232.

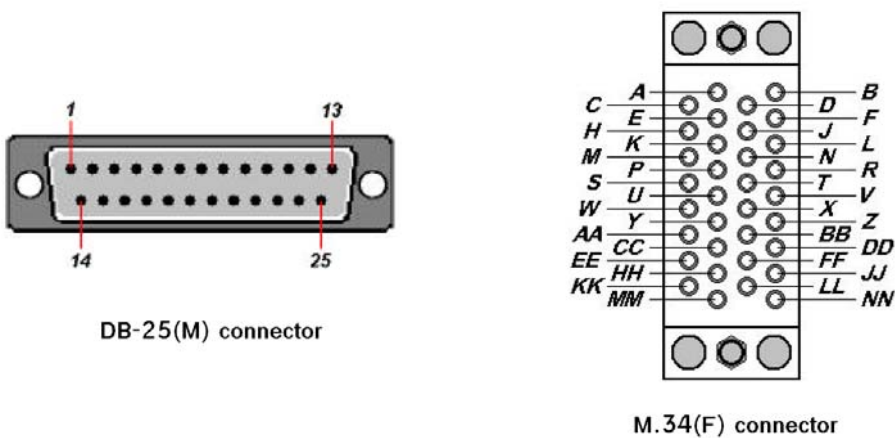

The front view of DB-25(M) connector and V.35(F) connector on this cable:

V.35 interface (34-pin Winchester type) contains the following signals:

Pin	Signal	Abbr.	DTE	DCE
A	Chassis Ground	FGND	---	---
B	Signal Ground	GND	---	---
C	Request To Send	RTS	Out	In
D	Clear To Send	CTS	In	Out
E	Data Set Ready	DSR	In	Out
F	Data Carrier Detect	DCD	In	Out
H	Data Terminal Ready	DTR	Out	In
J	Unassigned			
K	Unassigned			
L	Unassigned			
M	Unassigned			
N	Unassigned			
P	Send Data A	SD(A)	Out	In
R	Receive Data A	RD(A)	In	Out
S	Send Data B	SD(B)	Out	In
T	Receive Data B	RD(B)	In	Out
U	Terminal Timing A	SCTE(A)	Out	In
V	Receive Timing A	SCR(A)	In	Out
W	Terminal Timing B	SCTE(B)	Out	In
X	Receive Timing B	SCR(B)	In	Out
Y	Send Timing A	SCT(A)	In	Out
Z	Unassigned			
AA	Send Timing B	SCT(B)	In	Out
BB	Unassigned			
CC	Unassigned			
DD	Unassigned			
EE	Unassigned			
FF	Unassigned			
HH	Unassigned			
JJ	Unassigned			
KK	Unassigned			
LL	Unassigned			
MM	Unassigned			
NN	Unassigned			

6.4 X.21 DB25(M) to DB15(F) adaptor Cable

For X.21 applications, we must use the DB-25 to DB-15 adaptor cable to connect to a X.21 DTE DB-15 male cable.

The pin out of cable on DB-25(male) Connector to DB-15(Female) (X.21) Connector

DB-25 Pin	Signal	DB-15 (X.21) Pin	Description
1	FGND	1	Protective Ground
7	GND	8	Signal Ground
2	T	2	Transmit Data
14	T	9	Transmit Data
3	R	4	Receive Data
16	R	11	Receive Data
4	C	3	Request To Send
19	C	10	Request To Send
8	I	5	Data Carrier Detect
10	I	12	Data Carrier Detect
17	S	6	Receive Clock
9	S	13	Receive Clock

All signals are balanced. Meaning there is always a pair (+/-) for each signal, like those used in RS422. The X.21 signals are the same as RS422, so please refer to RS422 for the exact details.

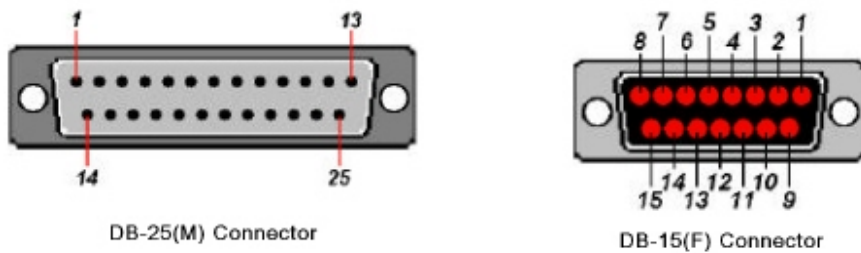

The front view of DB-25(M) connector and DB-15(F) connector on this cable:

The pin out of DB-15 connector on X.25 adaptor cable:

Pin	Signal	Abbr.	DTE	DCE
1	Shield	--	--	--
2	Transmit (A)	TA	Out	In
3	Control (A)	CA	Out	In
4	Receive (A)	RA	In	Out
5	Indication (A)	IA	In	Out
6	Signal Timing (A)	SA	In	Out
7	Unassigned			
8	Ground	--	--	--
9	Transmit (B)	TB	Out	In
10	Control (B)	CB	Out	In
11	Receive (B)	RB	In	Out
12	Indication (B)	IB	In	Out
13	Signal Timing (B)	SB	In	Out
14	Unassigned			
15	Unassigned			

Functional Description:

The Signal Element Timing (clock) (S) is provided by the DCE. This means that the NTU will output the correct clocking and that X.21 is a synchronous interface. Hardware handshaking is done by the Control (C) and Indication (I) lines. The Control is used by the DTE and the Indication is used by the DCE.

6.5 Console Cable

The front view of RJ-45 console cable socket on rear panel:

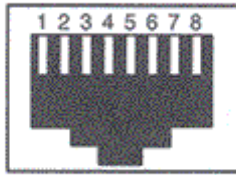

The wire connection of console cable DB-9(Female) to RJ-45:

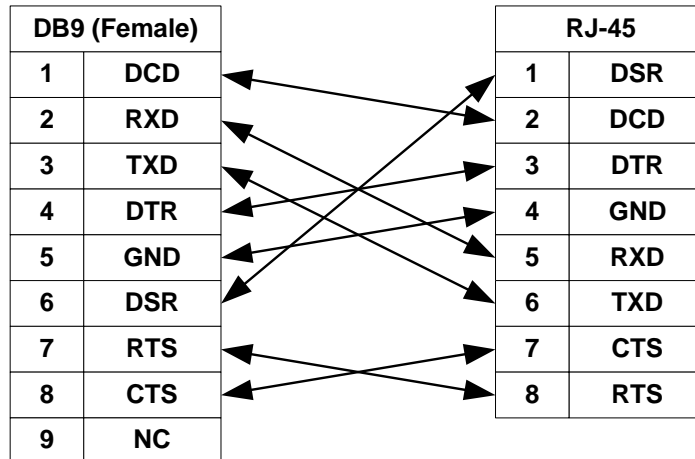

The signal direction of console cable:

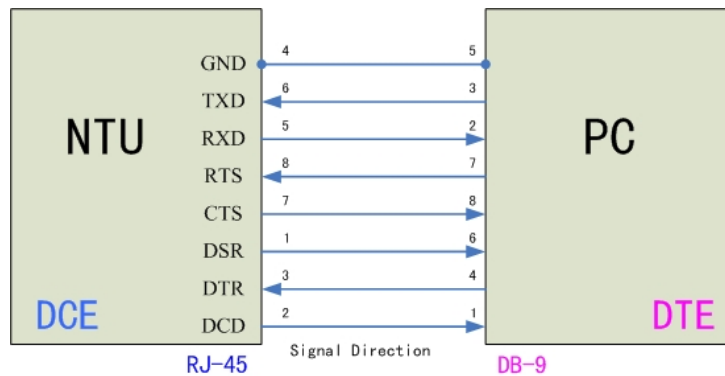

The pin assignment of RJ-45 modular jack on the console cable:

Pin Number	Abbrev.	Description	Figure
1	DSR	DCE ready	<p>Top View</p> <p>Front View</p>
2	DCD	Received Line Signal Detector	
3	DTR	DTE ready	
4	GND	Signal Ground	
5	RXD	Received Data	
6	TXD	Transmitted Data	
7	CTS	Clear to Send	
8	RTS	Request to Send	

6.6 E1/T1 Balanced Cable

The front view of RJ-48C E1/T1 balance cable socket on rear panel:

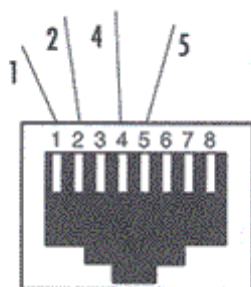

The pin out of RJ-48C plug on the G.703 120Ω E1/T1 balanced cable:

Pin Number	Description	Figure
1	E1/T1 interface receive pair-ring	<p>Top View</p> <p>Front View</p>
2	E1/T1 interface receive pair-tip	
3	No connection	
4	E1/T1 interface transmit pair-ring	
5	E1/T1 interface transmit pair-tip	
6	No connection	
7	No connection	
8	No connection	

The pin out of cable on DB-15(female) Connector to RJ-48C Connector:

DB15(Female) Pin Number	RJ-48C Pin number	Description
11	4	Transmit Ring
5	3	Rx Shield
9	1	Receive Ring
6	6	TX Shield
3	5	Transmit Tip
1	2	Receive Tip

Note: DB15 for E1 follows the AT&T pub 62411.

6.7 E1 Unbalanced Cable

Connections to the E1 BNC ports are made using a 75-ohm coaxial cable with a bayonet-style twist-lock BNC connector. We do not provide the cable. It is widely available from other sources.

The front view of BNC sockets on rear panel:



The internal wiring between BNC sockets and RJ-48C:

Signal Name	BNC Connectors	RJ-48C Connector
Transmit Tip	Center pin of Tx Connector	5
Transmit Ring	Shield of Tx Connector	4
Receive Tip	Center pin of Rx Connector	2
Receive Ring	Shield of Rx Connector	1

6.8 Ethernet Cable

The Ethernet cables should be 4 pair unshielded cable (UTP) or shielded (STP) of type CAT5 (or higher). Both crossed and normal wiring styles are supported by the auto-crossover feature of the NTU.

We do not provide the cable. It is widely available from other sources.

The front view of RJ-45 Ethernet cable socket on rear panel:

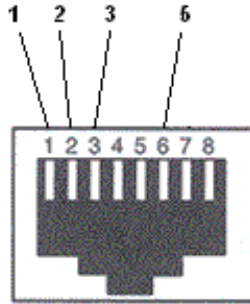

The pin out of RJ-45 Ethernet Connector:

Pin number	Signal Name
1	Transmit Data +
2	Transmit Data -
3	Receive Date +
4	Not used
5	Not used
6	Receive Date -
7	Not used
8	Not used

6.9 DSL Cable

The front view of DSL cable socket on rear panel:

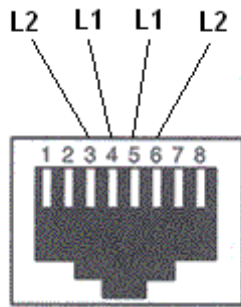

The pin out of RJ-45 modular jack on DSL cable:

Pin Number	Description	Figure
1	No connection	<p>Top View</p> <p>Front View</p>
2	No connection	
3	LOOP 2 Input/Output	
4	LOOP 1 Input/Output	
5	LOOP 1 Input/Output	
6	LOOP 2 Input/Output	
7	No connection	
8	No connection	

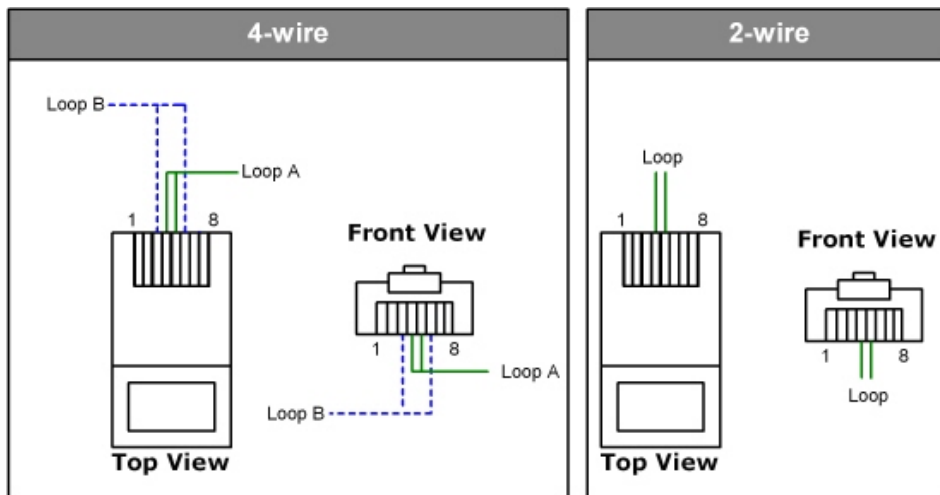

2-wires (1 Pair) Model	DSL loop Pin 4,5
-------------------------------	---------------------

4-wires (2 Pair) Model	DSL loop A Pin 4,5	DSL loop B Pin 3,6
-------------------------------	-----------------------	-----------------------

6.10 Power Cord

The front view of IEC-320 C6 type AC Inlet on rear panel:

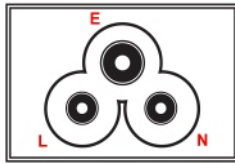

The pin out of AC Inlet connector:

Pin number	Description
E	Earth conductor
L	Live, hot or active conductor
N	Neutral or identified conductor

The socket of the power cord is using IEC-320 C5 type. This 3-conductor connector is colloquially called “Mickey Mouse” or “Clover Leaf” type.

The front view of C5 line socket of the power cord:

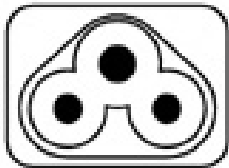

6.11 Illustration of Loopback connection device (E1)

RJ-48C Pin number	Description
4	Transmit Ring
3	Rx Shield
1	Receive Ring
6	TX Shield
5	Transmit Tip
2	Receive Tip

Make the short circuit/wiring with a RJ-45 module jack of the following:

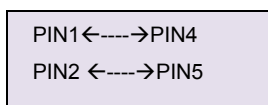

The top view of RJ-45 module jack on short circuit/wiring:

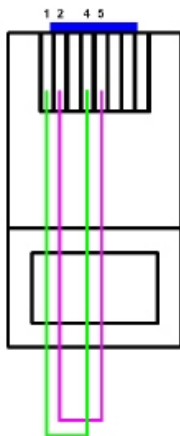

6.12 Illustration of Loopback connection device (Serial)

DB-25(M) Pin number	Signal	Description
2	TD(A)	Transmit Data
14	TD(B)	Transmit Data
3	RD(A)	Receive Data
16	RD(B)	Receive Data
4	RTS	Ready To Send
5	CTS	Clear To Send
6	DSR	Data Set Ready
20	DTR	Data Terminal Ready
24	XTC	DTE Transmit Clock
11	XTC	DTE Transmit Clock
15	TC(A)	Transmit Clock
12	TC(B)	Transmit Clock
17	RC(A)	Receive Clock
9	RC(B)	Receive Clock
1	FGND	Protective Ground
7	GND	Signal Ground
8	DCD	Data Carrier Detect

Make the short circuit/wiring with a DB-25(male) connector of the following:

PIN2 ←----→PIN3
PIN14←----→PIN16
PIN4 ←----→PIN5
PIN6 ←----→PIN20

The back side view of DB-25(male) connector on short circuit/wiring:

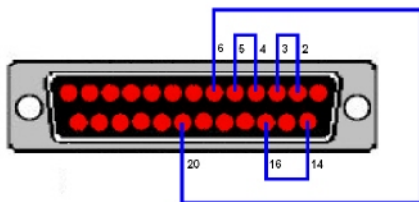



www.ctcu.com

T +886-2 2659-1021 F +886-2 2659-0237 E info@ctcu.com



ISO 9001 Quality System Certified CTC Union Technologies Co.,LTD.

All trademarks are the property of their respective owners. Technical information in this document is subject to change without notice.